

User Guide

FreeSpeak II for Eclipse HX User Guide

Eclipse HX 10.0 and above



Part Number: PUB-00064 Rev A

Date: February 03, 2021

Document reference

FreeSpeak II for Eclipse HX User Guide

Part Number: PUB-00064 Rev A

Legal disclaimers

Copyright © 2021 HME Clear-Com Ltd HME Clear-Com Ltd

All rights reserved

Clear-Com, the Clear-Com logo, and Clear-Com Concert are trademarks or registered trademarks of HM Electronics, Inc.

The software described in this document is furnished under a license agreement and may be used only in accordance with the terms of the agreement.

The product described in this document is distributed under licenses restricting its use, copying, distribution, and decompilation / reverse engineering. No part of this document may be reproduced in any form by any means without prior written authorization of Clear-Com, an HME Company.

Clear-Com Offices are located in California, USA; Cambridge, UK; Dubai, UAE; Montreal, Canada; and Beijing, China. Specific addresses and contact information can be found on Clear-Com's corporate website: www.clearcom.com

Clear-Com contacts:

Americas and Asia-Pacific Headquarters

California, United States

Tel: +1 510 337 6600

Email: CustomerServicesUS@clearcom.com

Europe, Middle East, and Africa Headquarters

Cambridge, United Kingdom

Tel: +44 1223 815000

Email: CustomerServicesEMEA@clearcom.com

China Office

Beijing Representative Office

Beijing, P.R. China

Tel: +8610 65811360/65815577

Table of contents

1 Important Safety instructions	6
1.1 Safety symbols	7
2 Introduction to FreeSpeak II®	8
2.1 An FS II communication system	8
2.2 FreeSpeak II with an FSII Transceiver (1.9 and 2.4)	9
2.3 FreeSpeak II with an FSII IP Transceiver	10
2.4 FSII 1.9 GHz/FSII 2.4 GHz	11
2.5 National Radio Carrier Frequencies	12
3 Installing a system	14
3.1 Installing and removing an E-IPA-HX card	14
3.2 Adding an E-IPA-HX card to the software	14
3.3 Adding the E-Que card for an FS II transceiver or splitter to the matrix	15
3.4 Connecting to transceivers	17
3.5 Clear-Com Cable Recommendations	19
4 Operating the wireless beltpack	21
4.1 Overview of the wireless beltpack	21
4.2 Beltpack user controls	24
4.3 Using the beltpack	29
5 Programming on the beltpack	35
5.1 Introduction to programming on the beltpack	35
5.2 Configuring the beltpack volume settings	36
5.3 Configuring the beltpack headset	37
5.4 Configuring the beltpack microphone	38
5.5 Configuring the beltpack display and LEDs	39
5.6 Configuring the beltpack alarm options	41
5.7 Selecting the beltpack role default set	43
5.8 Selecting the beltpack administration	43
5.9 Setting the listen again option	44
5.10 Control audio on keys C & D (beltpack)(advanced menu option only)	45
5.11 Accessing beltpack information	45
5.12 Setting display mode	46
5.13 Setting system connect	46
5.14 Enabling over the air (OTA) registration mode from a beltpack	46
5.15 Performing a site survey	48

6 Operating the FS II IP Transceiver (IPT)	49
6.1 IP rating (Protection Marking)	49
6.2 FS II IP Transceiver connector panel	50
6.3 IP Transmitter LEDs	50
6.4 IP Transceiver fans and filters	51
6.5 Reset the IPT to default	54
6.6 Transceiver standalone mode	54
6.7 Connecting the FS Transceivers to a matrix	54
6.8 Cabling the IP transceivers	58
6.9 Configuring the E-IPA-HX card for FreeSpeak II	59
6.10 Adding transceivers	60
6.11 Powering the transceiver	65
6.12 Upgrading the FS II IP Transceiver firmware	66
6.13 Upgrading from the matrix	66
6.14 Upgrading by USB connection	67
6.15 Port security settings	67
6.16 Network and synchronization	67
6.17 General network and switching rules	68
6.18 Beltpack support capacities for FS II IP Transceivers	68
6.19 Coverage areas under various conditions	69
6.20 FS II Transceiver setup rules and tips	69
6.21 Spare parts	70
7 Operating the FS II Transceiver	71
7.1 IP rating (Protection Marking)	71
7.2 FS II transceiver connector panel	71
7.3 Cabling the FS II transceivers	72
7.4 Beltpack support capacities for FS II Transceivers	77
7.5 Placing the transceivers and splitters	77
7.6 Determining coverage areas	79
7.7 Coverage areas under various conditions	80
7.8 FS II Transceiver setup rules and tips	80
7.9 Doing a site survey to determine coverage areas	81
7.10 Registering beltpacks	85
7.11 Upgrading FS II Transceiver firmware	86
7.12 Upgrading by USB connection	86
7.13 Upgrading by wireless connection	86
8 Using the FreeSpeak II Base splitter (FSII-SPL)	88

8.1 Configuration using a splitter with Cat 5/6 RJ45 connection	88
8.2 Configuration using a splitter with fiber connection	89
8.3 Splitter (FSII-SPL) rear connectors	90
8.4 Splitter (FSII-SPL) front panel	91
8.5 Using a transceiver with a fiber connection	91
8.6 Splitter Software Version (FSII-SPL)	93
9 Specifications	95
9.1 FreeSpeak II beltpack	95
9.2 FreeSpeak IP Transceiver	96
9.3 FreeSpeak II Transceiver	96
9.4 FreeSpeak II Transceiver Splitter	97
9.5 Transmission method	97
9.6 Notice about specifications	97
10 Regulatory compliance	98
10.1 FCC Notice	98
10.2 FCC/IC/EC RF Exposure Warning	98
10.3 Industry Canada Compliance Statement	99
10.4 Korean Notice	99
10.5 KCC 2.4Ghz warning	99
10.6 European Union (CE mark)	99
10.7 Taiwan Statements	100
10.8 Customs Union EAEU	101
10.9 Waste Electrical and Electronic Equipment (WEEE)	101

1

Important Safety instructions

- Read these instructions.
- Keep these instructions.
- Heed all warnings.
- Follow all instructions.
- Do not use this apparatus near water.
- Clean only with dry cloth.
- Do not block any ventilation openings. Install in accordance with the manufacturer's instructions.
- Do not install near any heat sources such as radiators, heat registers, stoves, or other apparatus (including amplifiers) that produce heat.
- Do not defeat the safety purpose of the polarized or grounding-type plug. A polarized plug has two blades and a third grounding prong. The wide blade or the third prong is provided for your safety. If the provided plug does not fit into your outlet, consult an electrician for replacement of the obsolete outlet.
- Protect the power cord from being walked on or pinched particularly at plugs, convenience receptacles, and the point where they exit from the apparatus.
- Only use attachments/accessories specified by the manufacturer.
- Use only with the cart, stand, tripod, bracket, or table specified by the manufacturer, or sold with the apparatus. When a cart is used, use caution when moving the cart/apparatus combination to avoid injury from tip-over.
- Unplug this apparatus during lightning storms or when unused for long periods of time.
- Refer all servicing to qualified service personnel. Servicing is required when the apparatus has been damaged in any way, such as power-cord supply or plug is damaged, liquid has been spilled or objects have fallen into the apparatus, the apparatus has been exposed to rain or moisture, does not operate normally, or has been dropped.
- Use only chargers provided by HME/Clear-Com to charge the battery packs or belt packs. These include:
 - BAT60 Battery pack and belt pack charger manufactured by HME/Clear-Com
 - USB Charger model PA1015-050SIB200/PA1015-1SI/ PA1015-1SI050200 provided by HME/Clear-Com with your belt pack.

- This product uses Lithium Ion Batteries which can be a fire hazard, if used improperly. Use only HME/Clear-Com supplied BAT60 or equivalent battery packs to ensure safe operation of the beltpack.
- When using AA Batteries follow all safety instructions from manufacturer. Do not mix different battery chemistries. When depleted, replace all batteries.
- The in-beltpack USB charging feature has only been tested utilizing USB2.0 port.

Warning: To reduce the risk of fire or electric shock, do not expose this product to rain or moisture.

1.1 Safety symbols

Familiarize yourself with the safety symbols. These symbols are displayed on the apparatus and warn you of the potential danger of electric shock if the system is used improperly.

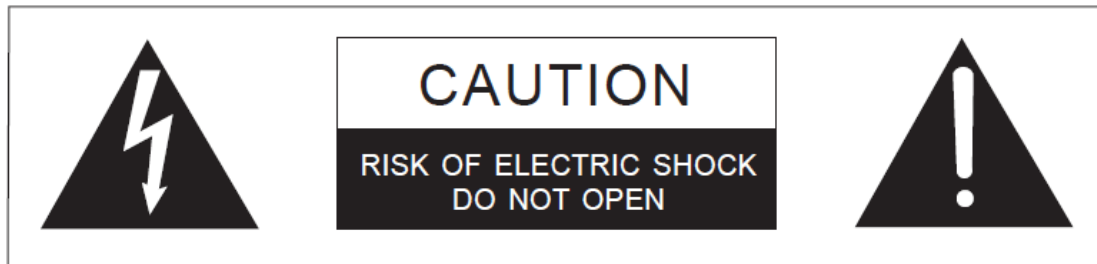

This symbol alerts you to the presence of uninsulated dangerous voltage within the product's enclosure that might be of sufficient magnitude to constitute a risk of electric shock. Do not open the product's case.



This symbol informs you that important operating and maintenance instructions are included in the literature accompanying this product.

Note: For compliance notices, see *Regulatory compliance*.

2 Introduction to FreeSpeak II®

With a FreeSpeak II (FS II) wireless beltpack you can roam freely around a site or facility while talking and listening to all, or selected, members of the production team. With its four communication routes, the beltpack gives you the flexibility to communicate quickly and seamlessly with individuals or groups, and to change communication routes as often as needed.

With FS II you can set up a wireless system specifically tailored to local needs by locating transceivers and beltpacks in areas where they are needed most. And because the beltpacks operate in the unlicensed 1.90 and 2.4 GHz frequency spectrum, there is no interference with existing wireless systems, even those located in the same area.

FreeSpeak II offers a choice of two transceivers:

- FS II transceiver that operates using E1 digital transmission
- FS II IP transceiver (IPT) that leverages your existing IP infrastructure for convenience and ease of installation.

With FreeSpeak II for Eclipse HX, wireless beltpack users can communicate with any Eclipse HX panel users on a one-to-one or group basis.

Note: *This User Guide covers the use of FS II with a matrix only (FS II for Eclipse HX). For more information on running an FS II system with a Base station, please see FreeSpeak II User Guide, Base Station Version.*

To use FreeSpeak II with a matrix, the matrix must be equipped with

- E-IPA-HX cards for connection to FS II IP transceivers
- E-Que cards in transceiver or splitter mode for connection to FS II transceivers.

The system must be configured using the Eclipse HX Configuration Software. For more detail, please refer to the Eclipse HX Configuration Software User Guide.

Note: *You cannot configure FreeSpeak and FreeSpeak II on the same Eclipse matrix. If you attempt to do so, the Eclipse HX Configuration Software displays a warning.*

2.1 An FS II communication system

An FS II system consists of three main elements:

- The wireless beltpacks.
- An Eclipse HX matrix (Omega, Median or Delta) with an E-IPA-HX card or E-Que card.
- The transceiver network that provides custom coverage zones in which beltpacks can operate. Beltpacks can roam freely between coverage zones.

FS II also includes a drop-in battery charger for the beltpack Li-Ion batteries. You can conveniently charge the battery by placing the whole beltpack into the charger, or by placing individual batteries into the charger.

FS II operates using a cellular network of transceivers located around a working environment. The transceivers connect to the matrix via an E-IPA-HX or E-Que card installed on the matrix. Each transceiver provides an area or cell in which up to ten full-duplex beltpacks can operate.

Beltpacks can roam among and between cells without disconnecting because each beltpack continually detects which transceiver has the strongest available signal. When the signal from a transceiver starts to diminish due to the distance from a beltpack, the beltpack automatically “hands off” its signal to the nearest transceiver, ensuring smooth transfer.

Note: *The E-IPA-HX card with IP Transceiver offers twice the beltpack density compared to the E-Que card.*

2.2 FreeSpeak II with an FSII Transceiver (1.9 and 2.4)

Using a transceiver splitter allows up to five transceivers to be connected to each transceiver port. Each E-Que card can connect to two splitters and so support up to 10 transceivers. Each transceiver supports up to five beltpacks. This means that up to 50 beltpacks can be present, giving a great deal of flexibility in placing beltpacks where they are needed most, and providing wireless reliability.

If a transceiver card is selected in the configuration software, this supports 8 transceivers.

Note: *Each transceiver is designed to handle five beltpacks in the 1.9 GHz range and four in the 2.4 GHz range, simultaneously and in good conditions. However, if interference or propagation problems occur in an area, to ensure proper operation and reliability, it may be more practical to install one less beltpack for each transceiver.*

For zones which are likely to need coverage for up to five or more beltpacks simultaneously you must install a second transceiver. Similarly, for good coverage for nine or more beltpacks simultaneously, a third transceiver may be required.

Radio Frequency (RF) Band	Minimum number of transceivers in one RF cell	Maximum number of beltpacks supported in one RF cell
1.9 GHz	1	4 - 5
	2	8 - 10
	3	12 - 15

Radio Frequency (RF) Band	Minimum number. of transceivers in one RF cell	Maximum number of beltpacks supported in one RF cell
	4	16 - 20
2.4 GHz	1	3 - 4
	2	4 - 6
	3	7 - 9
	4	10 - 12

2.3 FreeSpeak II with an FSII IP Transceiver

Using the FreeSpeak II system with an IP transceiver increases the capacity and range of your system.

- The IP transceiver is used with the E-IPA-HX card (Eclipse 10.0 and above software).
- E-IPA-HX card operates on a license basis. You can buy a card with a 16, 32, 48 or 64 port license.

The E-IPA card enables up to 64 FS II connections (according to license) which may be made up of any combination of:

- FS II IP Transceivers (up to 64)
- FS II beltpacks (up to 64)

Radio Frequency (RF) Band	Minimum number. of transceivers in one RF cell	Maximum number of beltpacks supported in one RF cell
1.9 GHz BV32 codec	1	8 - 10
	2	16 - 20
	3	24 - 30
	4	32 - 40
2.4 GHz	Not supported	Not supported

Note: *The IP Transceiver supports up to 10 beltpacks, but to enable effective roaming Clear-Com recommends eight beltpacks per transceiver.*

2.4 FSII 1.9 GHz/FSII 2.4 GHz

FreeSpeak II 1.9 GHz frequency range devices
(DECT/Digital Enhanced Cordless Telecommunications
frequency)



FreeSpeak II 2.4 GHz frequency range devices
(ISM, Industrial, Scientific and Medical frequency)
Not for use with the IP transceiver



FSII-TCVR-24



Power status LED = Blue
Data synch status LED = Amber



FSII-BP-24

2.5 National Radio Carrier Frequencies

The carrier frequencies allocated for a radio space vary according to location. This affects the amount of belt packs that can be supported in one RF area.

Location	Number of carrier frequencies	Maximum belt packs in one RF cell
United States	5	25 belt packs, 50 belt packs with the FreeSpeak II IP Transceiver
European Union and elsewhere	10	50 belt packs, 100 belt packs with the FreeSpeak II IP Transceiver

Note:

If necessary, using two RF bands (1.9 GHz and 2.4 GHz) will increase the amount of belt packs that can be used in one area or cell.

3 Installing a system

This chapter explains how to install a FreeSpeak II system, including cable connections, registering backpacks and performing a site survey to optimize system performance.

A FreeSpeak II system can be used with an Omega, Median or Delta matrix.

3.1 Installing and removing an E-IPA-HX card

To install an E-IPA-HX card:

1. Carefully place the card in the appropriate slot. Make sure the card is aligned with the top and bottom precision guides.
2. Push the card toward the backplane connectors.
3. When the card has almost reached the backplane connectors, open the two ejector tabs, allowing them to clear the edges of the matrix. Gently insert the card further until it touches the backplane connector guides.
4. Gently close both ejector tabs at the same time, to propel the card into the backplane connectors.

3.1.1 To remove an E-IPA-HX card from the matrix

1. Hold the card in place in the matrix.
2. The two card ejector tabs are located at the top and bottom of the card. To remove a card, open the two ejector tabs at the same time until the card unseats from its backplane connectors.
3. Pull the card out of the matrix.

3.2 Adding an E-IPA-HX card to the software

To add an E-IPA-HX card to the software:

1. In the EHX configuration software go to: **Hardware > Cards and Ports**, and then navigate to an available slot number (marked **Empty**). Do either of the following:
 - a. Double click the slot.
 - b. Right click the slot and select Set Card Type.
2. Select a card type from the drop-down menu listing the available card types.

Note: *You cannot have both E-IPA-HX cards and E-Que card on the same matrix.*

3.3 Adding the E-Que card for an FS II transceiver or splitter to the matrix

Note: *You can only use the FS II splitter with FS II transceivers that connect to an E-Que card. You cannot use the splitter with the FreeSpeak II IP Transceiver.*

The E-Que card is designed to allow Eclipse HX matrices to connect to FreeSpeak and FreeSpeak II wireless transceivers/beltpacks or connect together using E1 or T1 protocol. You will need an E-Que card and a rear port. You will need to make sure the E-Que card is physically connected to the matrix and configured for communication in the Eclipse software. See 3.1.1 and 3.1.2. below.

3.3.1 Installing and removing an E-IPA-HX or E-Que card.

To install a card:

1. Carefully place the card in the appropriate slot. Make sure the card is aligned with the top and bottom precision guides.
2. Push the card toward the backplane connectors.
3. When the card has almost reached the backplane connectors, open the two ejector tabs, allowing them to clear the edges of the matrix. Gently insert the card further until it touches the backplane connector guides.
4. Gently close both ejector tabs at the same time, to propel the card into the backplane connectors.

To remove a card from the matrix

1. Hold the card in place in the matrix.
2. The two card ejector tabs are located at the top and bottom of the card. To remove a card, open the two ejector tabs at the same time until the card unseats from its backplane connectors.
3. Pull the card out of the matrix.

3.3.2 Adding an E-Que card to the software

To add an E-Que card to the software:

1. In the EHX configuration software, go to **Hardware > Cards and Ports**, and navigate to an available slot number (marked Empty).
2. Do either of the following:
 - Double click the slot.
 - Right click the slot and select **Set Card Type**.

3. A drop-down menu is displayed, listing the available card types. Select an FS II transceiver or splitter from the drop-down menu.

You cannot have both E-Que Transceiver/Splitter and E-Que FS II Transceiver/Splitters configured on the same matrix.

For information about integrating 2.4 GHz FSII with 1.9 GHz FSII IP, please contact Clear-Com Technical Support.

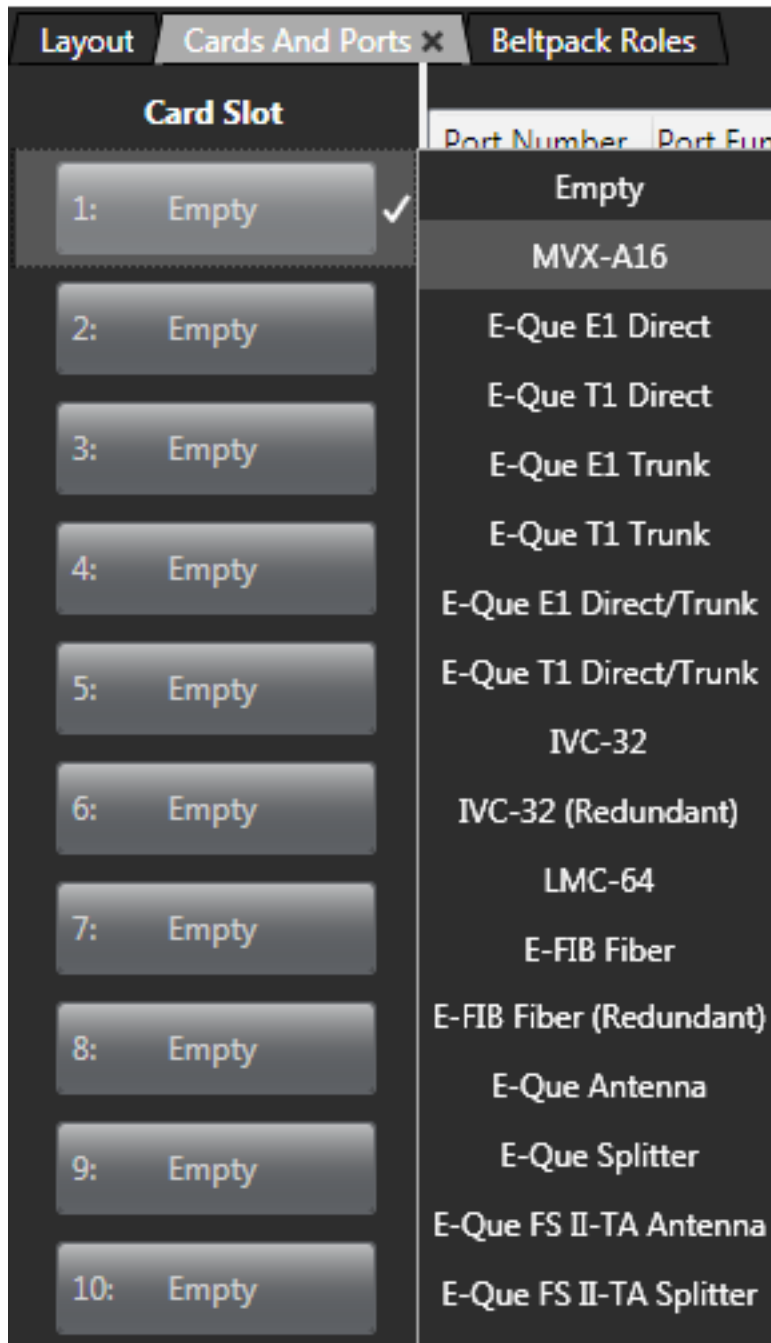

3.3.3 Selecting an FS II-TA transceiver card type

Selecting an FS II-TA transceiver card type automatically configures an E-Que card with eight transceiver ports (1 to 8 on the rear card). Each of those transceiver ports provides five user ports and one control port.

3.3.4 Selecting an FS II-TA splitter card type

Selecting an FS II-TA splitter card type automatically adds an E-Que card with two splitter ports (1 and 5 on the rear card) configured. Each splitter can support up to five transceivers and each transceiver provides five beltpack ports.

Note: *At this stage you might choose to register all of the beltpacks with the matrix, or at least register one or two for system setup and testing. See Eclipse HX Software Configuration User Guide, 5.59 FreeSpeak II Beltpacks.*

3.4 Connecting to transceivers

3.4.1 Connecting one transceiver directly to a transceiver port

A transceiver connects to the transceiver port on the E-Que card using a standard 4-pair CAT-5 data cable with RJ-45 connectors. If the transceiver is locally powered, it may be located up to 800 metres from the matrix if 24AWG cable is used or for 400 metres if 26AWG cable is used creating a coverage area for five FS-BP wireless beltpacks in that location.

Note: *It is recommended that shielded CAT-5 cable or better is used.*

To know that a transceiver is active, observe the green power LED and the yellow signal LED on the face of the unit where the RJ-45 connector is connected. Both must be lit. Also, wireless beltpacks in the vicinity of the active transceiver will be connected to the system and their displays will show labels and other information.

For the best, most reliable coverage, it is advisable to use a minimum of two transceivers in any installation, positioned in different locations in the coverage area. When more transceivers are required to support a larger coverage area or more wireless beltpacks, a transceiver splitter will need to be introduced.

In some situations, particularly in outdoor venues, interference from non-DECT sources can severely reduce the range of the system. In these cases we recommend a site survey as described in Chapter 8, "Installing a System".

3.4.2 Connecting transceivers with a splitter (PD2203)

Note: *You can only use the FS II splitter with FS II transceivers that connect to an E-Que card. You cannot use the splitter with the FreeSpeak II IP Transceiver.*

A splitter (PD2203) will connect up to five transceivers to one of the transceiver ports on the E-Que card, creating up to five coverage zones that can be overlapped to make large areas where

beltpacks can have continuous coverage. The use of the splitter also extends the distance that the transceivers can be located from the matrix to 1600 metres (5250 feet) if 24AWG cable is used or 800 metres (2625 feet) if 26AWG cable is used (assuming the same cable type is used to connect the transceiver to the splitter and the splitter to the matrix).

Note: *It is recommended that shielded CAT-5 cable or better is used.*

For example, a splitter can be used to connect to a matrix that is located in a production truck outside an arena or stadium, with a single CAT-5 cable going to the splitter which is then located just inside the stadium. From that splitter, up to five transceivers are distributed throughout the stadium to create wide coverage – each with a run of CAT-5 cable back to the splitter. A similar arrangement may be used in a large theatre or performing arts facility.

The connection between a transceiver port on the E-Que card and a PD2203 splitter is accomplished with standard 4-pair CAT-5 data cable with RJ-45 connectors. It is connected to the port labeled MATRIX on the splitter. The splitter must be locally powered via its DC IN connector, using the in-line external universal power supply.

Note: *The RJ-45 ports on the splitter labeled “1” through “5” are the connections to the FS-TA transceivers.*

Ports 1 and 5 on the E-Que card are connections to the PD2203 splitter.

Note: *You must set the card type to Splitter mode in Cards and Ports in the EHX software interface before connecting the devices. See section 3.1.2. for more detail.*

Note:

Maximum Cable Lengths and Powering, FreeSpeak II for Eclipse-HX

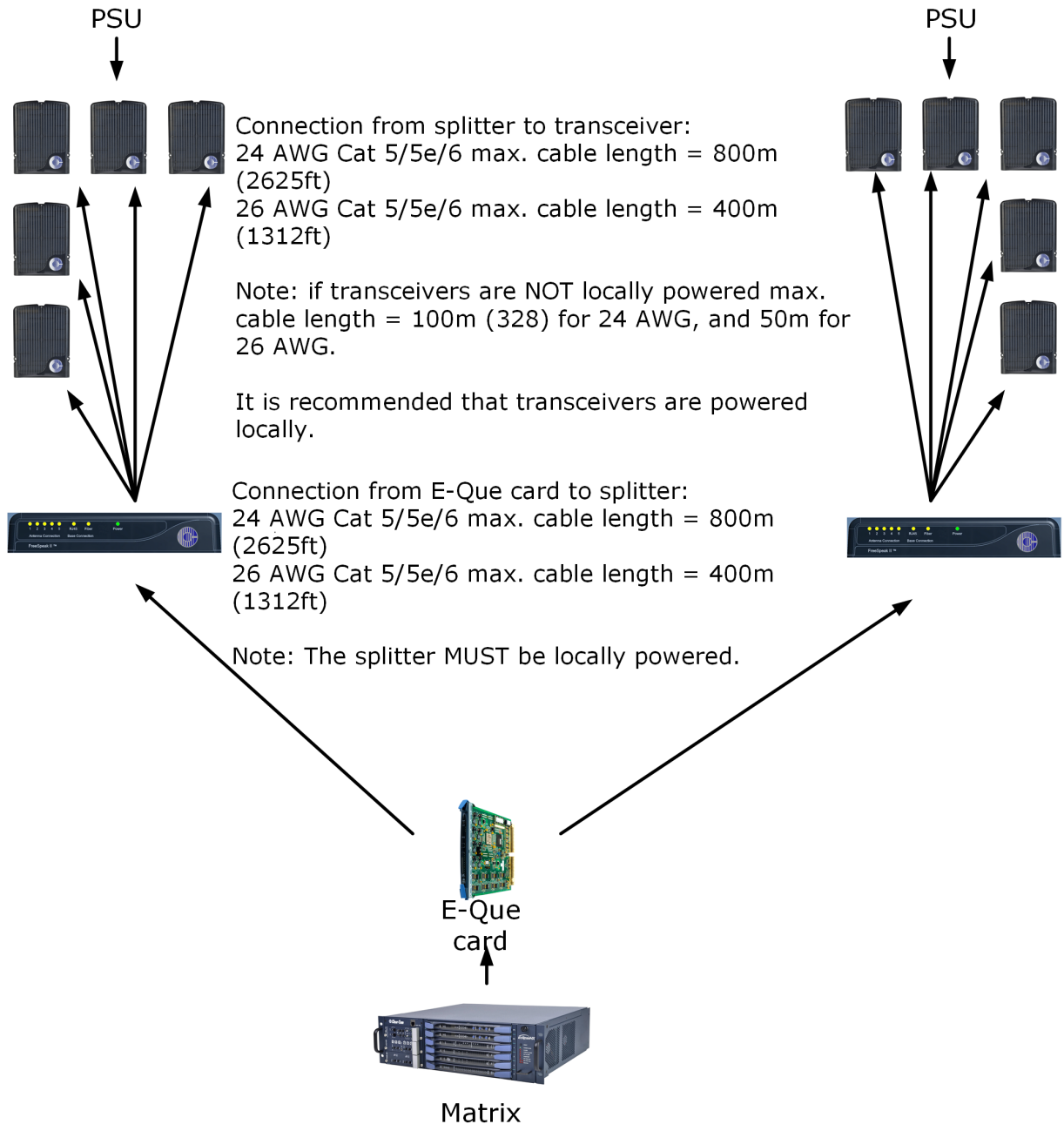

3.5 Clear-Com Cable Recommendations

Use the following Category (Cat), American Wire Gauge (AWG) and shielded cable types.

Specification	Description
Category (Cat)	<ul style="list-style-type: none"> Higher Cat numbers will support a higher bandwidth. Therefore, by using a higher Cat number, you are future proofing your system to some extent. Example: Cat 5e; up to 1GB. Cat 6; up to 10GB. Use Cat 5e or higher.
American Wire Gauge (AWG)	<ul style="list-style-type: none"> The lower the AWG number, the less temperature rise there will be in the cable when using PoE. This is particularly important for bundles. Local building regulations may rule out the use of 26AWG or higher, depending on the installation. Check with your local building regulations. Use AWG 24 or lower.
Shielded Twisted Pair (STP) or Foiled Twisted Pair (FTP)	Using shielded cable means less problems with interference from other sources. This means that your network will be more robust if you use shielded cables.
Overall Recommendation	Use Cat 6a 23 AWG STP cable.

4 Operating the wireless beltpack

This chapter explains how to operate the FS II beltpack. It contains the following sections:

- **Overview of the wireless beltpack on page 21**
- **Beltpack user controls on page 24**
- **Using the beltpack on page 29**

4.1 Overview of the wireless beltpack



An FS II wireless beltpack gives you simultaneous access to up to five channels of talk/listen communication, with the ability to switch among them as desired. Any or all of these routes may be kept open during use. You can adjust Incoming volume levels (“listen levels”) using the two rotary level controls, so that one conversation can be monitored in the background while a primary conversation is held.

The panel display contains the role (label) of the beltpack user, identifies up to four talk/listen labels currently selected, and gives other information such as signal strength and battery level. You can choose between two display modes:

- Intercom display mode – displays key labels, role name, signal strengths, battery level and volume levels.

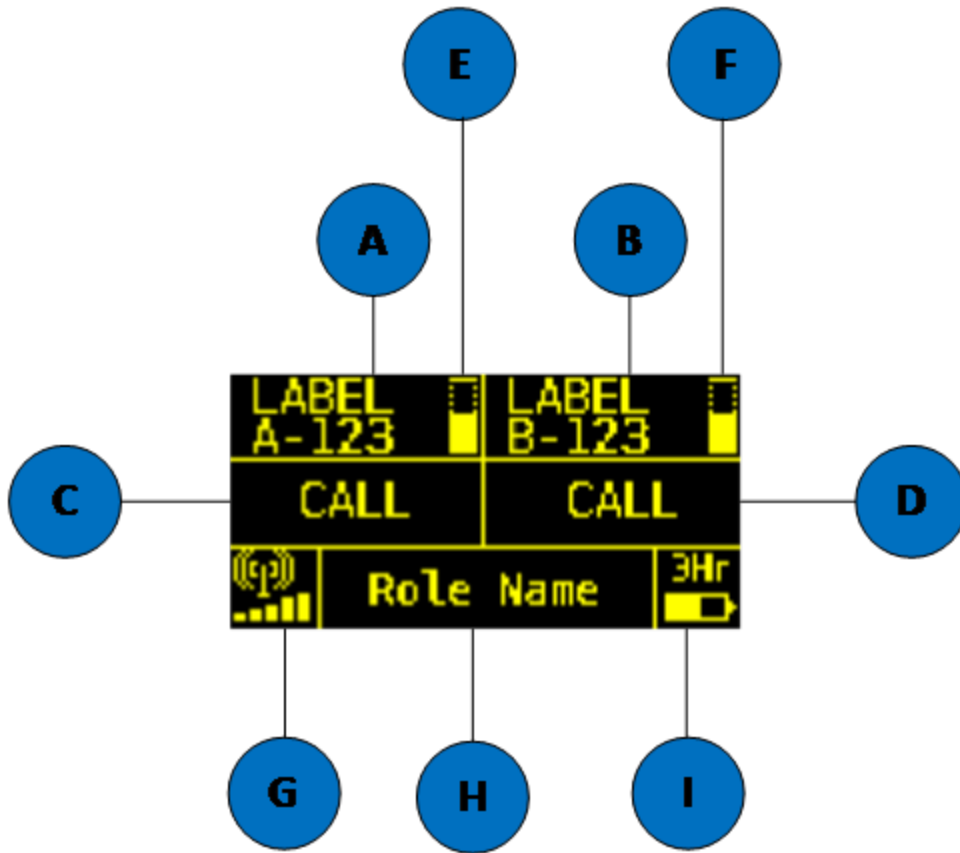

- Partyline display mode – displays role name, signal strength, battery level and volume levels for channel A and channel B.

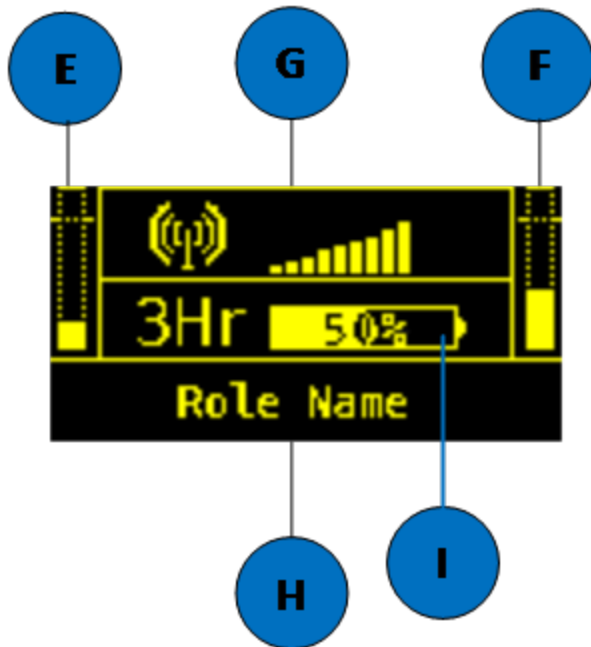

Key to display layout	
Feature	Description
A	Label for key A assignment.
B	Label for key B assignment.
C	Label for Key C Assignment or CALL key for Key A if not assigned.
D	Label for Key D Assignment or CALL key for Key B if not assigned.
E	Volume level for Key A assignment.
F	Volume level for Key B assignment.
G	Signal strength.
H	Role name for the role assigned to the Beltpack.
I	Battery life remaining (in hours for Li-Ion, in % for AA battery).

A 4-pin male headset connector is provided for connection with a standard Clear-Com headset or similar device. The FS II beltpack will operate for approximately 18 hours using a rechargeable Li-Ion battery. Real operational times depend on usage and quality of batteries used. You can also use AA batteries, but you must not attempt to recharge them.

On the bottom of the beltpack, there is an LED torch with a latching key that provides a quick and convenient source of illumination when working in poorly lit areas.

4.2 Beltpack user controls

4.2.1 Top controls

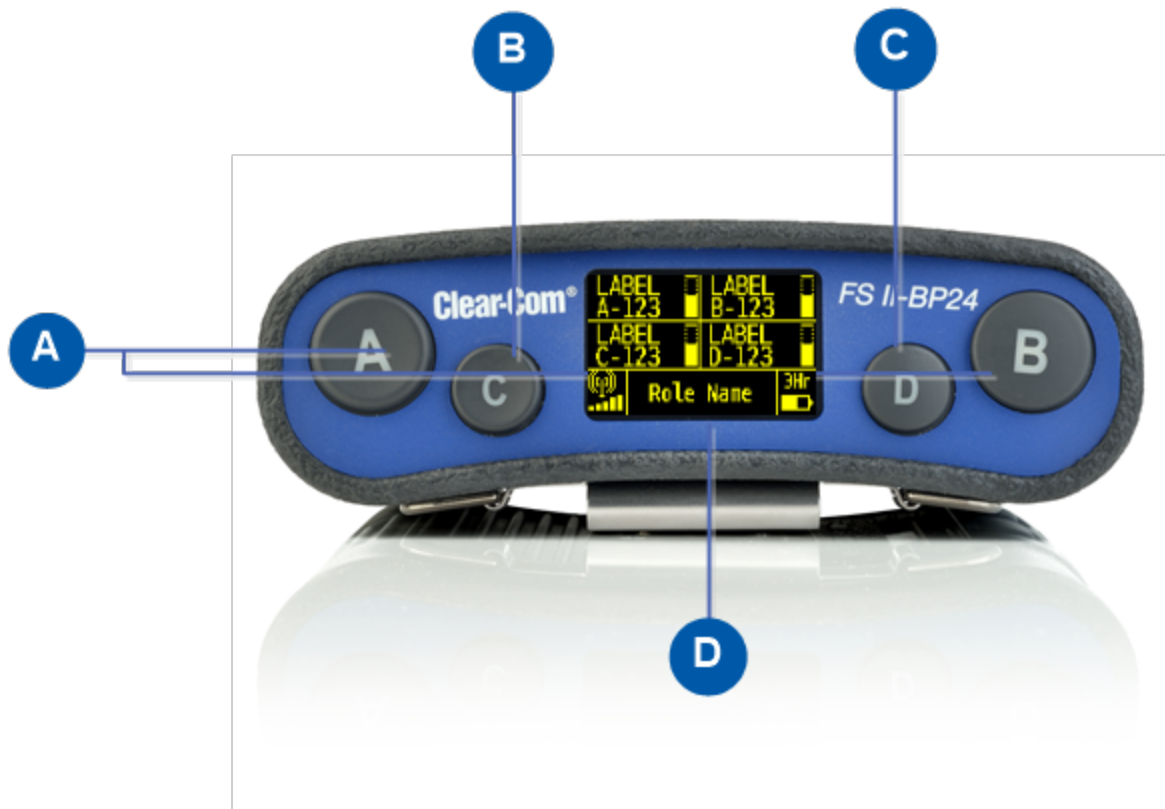





Key to beltpack top controls

Feature	Description
A	Talk key A and B. Press to talk or listen on channel A and channel B.
B	Talk key C. Press to talk or listen on channel C. In menu mode, press to cancel menu.
C	Talk key D. Press to talk or listen on channel D. In menu mode, press to select menu.
D	Display. When the beltpack is not in menu mode, information about each of the four channels supported by the beltpack is displayed on screen. Exactly what is present on the screen depends on the display mode (intercom or partyline).

4.2.2 Beltpack display

The following table lists the beltpack display icons and indicators.

Beltpack display icons and indicators		
Name	Icon	Description
Key label		A descriptive name for the channel. The maximum length is 10 characters.
Role name		A descriptive name for the beltpack role.
Channel listen volume level		The volume of the channel audio.
Signal strength		Bars that indicate the strength of the signal from the Main Station.
Battery level		Indicates the battery time remaining.

4.2.3 Beltpack headset tones/alerts

Note: To change call signal, low battery or out-of-range alerts go to Menu (press and hold) -> Settings -> Alarm options on your beltpack. Choose from Vibrate & audio/Vibrate only/Audio only/Off.

Beltpack headset tones/alerts	
Event	Tone
Call signal	Mid to high beep, as long as call is active Mid on 200ms, mid off 0ms, high on 200ms, high off 400ms. Repeat if key held.
Low battery	High beep, long then short. High, on 400ms, off 100ms, on 100ms. Repeats intermittently.
Out-of-range	High beep, long then short (as above). Repeats as long as beltpack is out of range.

Beltpack headset tones/alerts

Menu button	Mid beep. Mid, on 100ms, off 100ms. Triggers on entering menu mode.
Power button	Mid beep. Mid, on 100ms, off 100ms, repeated while power button pressed.
Listen again	Low beep. Low, on 100ms, off 100ms.

4.2.4 Front controls



Key to beltpack front controls

Feature	Description
A	Right rotary level control. Turn clockwise or counter-clockwise to adjust volume. In menu mode, turn clockwise or counter-clockwise to navigate the menus.
B	Power button. Press to power up or power down the beltpack.
C	Reply key. Reply key can be configured as an extra fifth channel using the Configuration Editor or EHX software.
D	Mnu key. Press firmly for about two seconds to enter menu mode. To exit menu mode, press the menu key again. If you tap the Menu key, the Listen Again feature is activated. See Setting the listen again option on page 44 .
E	Left rotary level control. Turn clockwise or counter-clockwise to adjust volume. In menu mode, turn clockwise or counter-clockwise to navigate the menus.

4.2.5 Beltpack bottom connectors

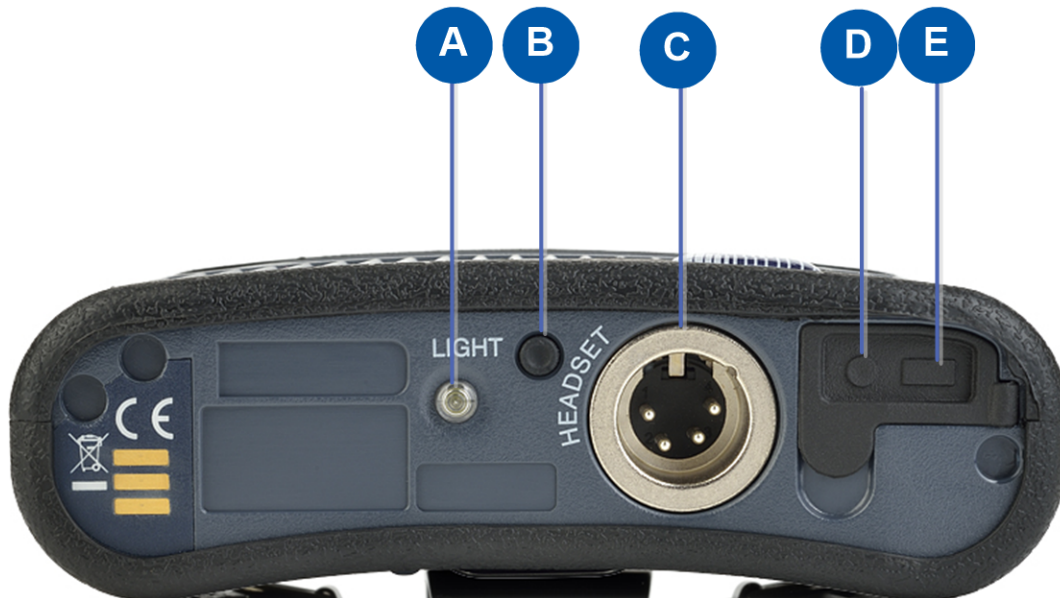

Key to backpack bottom connectors																
Feature	Description															
A	LED torch															
B	LED torch control															
C	Headset socket (4-pin XLR-M)															
	<table border="1"> <thead> <tr> <th>Pin</th> <th>Function</th> </tr> </thead> <tbody> <tr> <td>1</td> <td>Mic ground</td> </tr> <tr> <td>2</td> <td>Mic +</td> </tr> <tr> <td>3</td> <td>Earphone ground</td> </tr> <tr> <td>4</td> <td>Earphone</td> </tr> </tbody> </table> <p>Headset socket pin out</p>	Pin	Function	1	Mic ground	2	Mic +	3	Earphone ground	4	Earphone					
Pin	Function															
1	Mic ground															
2	Mic +															
3	Earphone ground															
4	Earphone															
C	Headset socket (7-pin XLR-M)															
	<table border="1"> <thead> <tr> <th>Pin</th> <th>Function</th> </tr> </thead> <tbody> <tr> <td>1</td> <td>Mic ground</td> </tr> <tr> <td>2</td> <td>Mic +</td> </tr> <tr> <td>3</td> <td>Ground</td> </tr> <tr> <td>4</td> <td>Left Headphone Output</td> </tr> <tr> <td>5</td> <td>Right Headphone Output</td> </tr> <tr> <td>6</td> <td>PTT1</td> </tr> <tr> <td>7</td> <td>PTT2/Headset detect</td> </tr> </tbody> </table> <p>Headset socket pin out</p>	Pin	Function	1	Mic ground	2	Mic +	3	Ground	4	Left Headphone Output	5	Right Headphone Output	6	PTT1	7
Pin	Function															
1	Mic ground															
2	Mic +															
3	Ground															
4	Left Headphone Output															
5	Right Headphone Output															
6	PTT1															
7	PTT2/Headset detect															
D	3.5 mm stereo jack.															
E	Micro USB connector.															

4.2.6 Beltpack rear panel



Key to beltpack rear panel

Feature	Description
A	Beltpack clip
B	Beltpack battery compartment

4.3 Using the beltpack

4.3.1 Registering the beltpack

Before you can use a beltpack, you must first register it with the FreeSpeak II system. For more information, see the Eclipse HX Software Configuration User Guide, 5.59 FreeSpeak II Beltpacks.

4.3.2 Charging the beltack

Use only chargers provided by HME/Clear-Com to charge the battery packs or beltacks. These include:

- BAT60 Battery pack and beltack charger manufactured by HME/Clear-Com
- USB Charger model PA1015-050SIB200/PA1015-1SI/ PA1015-1SI050200 provided by HME/Clear-Com with your beltack.

The beltack batteries are located inside the beltack battery compartment. The beltack can use a Clear-Com rechargeable Li-Ion battery or AA batteries. The AC60 battery charger can charge up to five batteries simultaneously.

To recharge the beltack battery:

1. Insert either the beltack containing the battery, or the battery itself into one of the recharging bays on the battery charger. A red LED indicates that the battery is recharging.

If you are recharging the battery while it is still in the beltack battery compartment, an illuminated beltack key (Talk key A) indicates the charging status. The beltack charging sequence depends on whether you insert a powered on or powered off beltack into the charger. The table below shows the charging status conditions.

Talk key A red	Talk key A green	RF component	Beltack screen
Battery charging	Battery fully recharged	Disabled	Displays current percentage charge and software version

If a beltack is powered on when placed in the charger, on removal the RF component is re-enabled and the beltack attempts to reconnect to its previous connection.

If a beltack is powered off when placed in the charger, on removal it will power off.

2. Wait until the recharging LED turns from red to green. The battery is now fully recharged.



4.3.3 How to set AA battery type: Nickel-metal hydride (NiMH) or Alkaline for wireless beltpacks

FreeSpeak II wireless beltpacks are supplied with Li-Ion batteries and battery charger. However, in some cases you may wish to use AA batteries. You may need to use standard AA alkaline batteries, or in a high atmospheric pressure (hyperbaric) environment, where you can't use Li-Ion batteries, you may need to use NiMH batteries.

When using AA batteries of either kind, it is helpful to set battery type so that battery capacity can be monitored accurately. NiMH batteries and alkaline batteries have different discharge patterns and setting this option will allow for that.

AA Battery type must be set in the EHX software.

1. Open the EHX configuration software and navigate to Preferences/Wireless Beltpacks/Battery type.
2. Select required battery type, NiMH or Alkaline.

Note: *The default setting for AA battery type is Alkaline.*

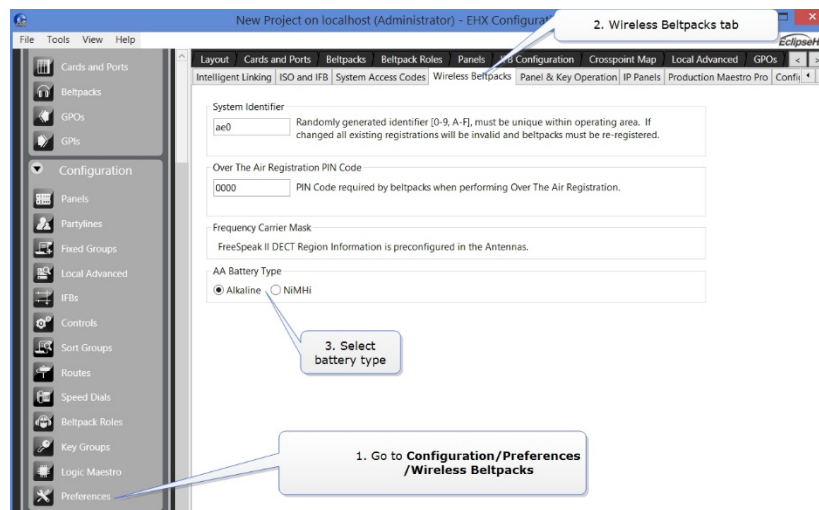

4.3.4 Powering on the beltpack

The recessed power button is used to turn the FS II beltpack on and off. Press and hold the button for about three seconds to turn the beltpack on. To turn it off, press and hold the button for about three seconds.

4.3.5 Using the beltpack to communicate

The beltpack has four keys labelled A, B, C, D and Reply. You can program each of these keys to determine their communication destinations, and the type of communication possible. For example, a key could be programmed to call a partyline channel, with both talk and listen enabled.

You can program the beltpack keys by using the Eclipse HX software. For more information, see the Eclipse HX Configuration Software User Guide.

To talk to all the devices connected to the channel:

1. Connect a headset, using the 4-pin XLR–M connector on the base / rear of the beltpack.
2. Press the appropriate key.
3. While the key is held down audio transmits on that channel. When the key is released audio no longer transmits. To latch a key on for hands-free use, quickly tap the key. Another quick tap releases the latch.
4. Speak into the headset microphone.
5. To adjust the volume of incoming audio for a channel, turn the appropriate side-mounted rotary control. Turn the rotary control clockwise to increase the volume, and counter-clockwise to decrease volume. The current volume level for the channel is shown on screen.

4.3.6 Entering and exiting Menu mode

Use Menu mode to:

- Configure the settings for the beltpack.
- Read beltpack information such as software version
- Perform a site survey to maximize signal strength and coverage.

To enter Menu mode, press and hold the Menu key for three seconds. To exit Menu mode, press the Menu key again.

For more information about using Menu mode on the beltpack, see **Introduction to programming on the beltpack on page 35**.

4.3.7 Setting and Adjusting Listen Levels

You can adjust a beltpack's incoming audio volume in two ways:

- The master volume level for the beltpack can be set by using the beltpack menu options. See **Configuring the beltpack volume settings on page 36**.
- The incoming audio level can be adjusted during talk or listen on the beltpack using the beltpack's rotary level controls.

To adjust the listen level during talk or listen from the beltpack:

- During talk and listen, use the rotary level control to increase or decrease the incoming volume level ("listen level") for that assignment.

Note: *You can also configure the incoming audio volume using the EHX software.*

4.3.8 Upgrading beltpack firmware

You can upgrade the FreeSpeak II beltpack firmware by:

- Using a USB connection (the upgrade file for USB has a .fws extension).
- Using an Over The Air upgrade.

4.3.9 Upgrading by USB connection

1. Connect the beltpack to a USB port on the computer running the EHX software.
2. Select **Tools > Apply Wireless Firmware Via USB**.
3. Browse to the location of the upgrade file, and then select Update Firmware. The upgrade file for USB has a .fws extension.

The upgrade file is downloaded to the beltpack or transceiver.

Note: *You can connect more than one beltpack to the computer if you have multiple USB ports. The units will be upgraded sequentially.*

4.3.10 Upgrading beltpack firmware by Over The Air Upgrade

Note: *You must first upgrade the Transceivers before upgrading the beltpacks.*

1. Right-click on the Frame in the Layout window, and then select Firmware > Update Firmware. The Update Firmware Wizard appears.
2. Select Next. The following screen appears:

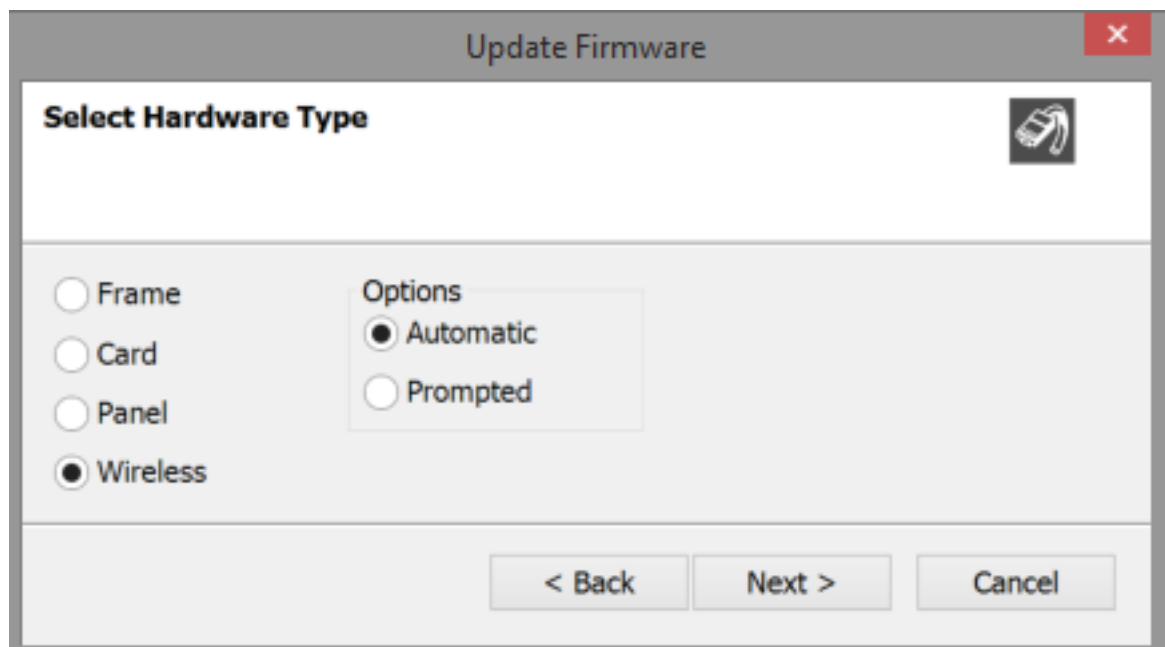

3. Select the **Wireless** radio button. There are two further options:
 - **Automatic** – select this option to automatically upgrade the beltpack when it is switched on.
 - **Prompted** – select this option to allow the beltpack user to confirm the upgrade.
4. Select **Next**, and then browse to the upgrade file (.fww) and select **Open**. The upgrade file is loaded to the transceiver. The upgrade file is downloaded to all the connected beltpacks, and the beltpacks automatically restart.

The transceivers store the beltpack upgrade files until they are power cycled or there is a black reset.

You can track the status of the download in the EHX Event Log, and for beltpack upgrades the upgrade status is also shown on the beltpack display.

5 Programming on the beltpack

This chapter explains how to program the beltpack using the beltpack's menu system. It contains the following sections:

- **Introduction to programming on the beltpack on page 35**
- **Configuring the beltpack volume settings on page 36**
- **Configuring the beltpack headset on page 37**
- **Configuring the beltpack microphone on page 38**
- **Configuring the beltpack display and LEDs on page 39**
- **Configuring the beltpack alarm options on page 41**
- **Selecting the beltpack role default set on page 43**
- **Selecting the beltpack administration on page 43**
- **Setting the listen again option on page 44**
- **Accessing beltpack information on page 45**
- **Setting display mode on page 46**
- **Setting system connect on page 46**
- **Enabling over the air (OTA) registration mode from a beltpack on page 46**
- **Performing a site survey on page 48**

5.1 Introduction to programming on the beltpack

You can access the beltpack menu by pressing and holding the menu key. The Master Menu screen is displayed. This consists of the following submenus:

- Volume Level Control
- Volume Operation
- Line In Volume Level
- Settings
- Information
- Display Mode
- System Connect

- Site Survey

Note: *The menus that appear depend on the menu access level. See [Setting full menu access on page 43](#).*

To select a submenu turn either of the two rotary dials clockwise. This will scroll down the submenu options. If you turn the rotary dials counter-clockwise, you will scroll upwards.

To select a submenu, press the Menu Select key (D).

To return to the previous screen, press the Menu Cancel key (C). You can also return to the previous screen by pressing the Menu key.

Each menu screen on the beltpack has the following structure:

- Header - this displays the menu title
- Body - this displays a scrollable list of menu items
- Footer - this displays the current value of the current menu selection

To exit the beltpack menus, press the Menu key.

5.2 Configuring the beltpack volume settings

You can configure the following:

- The volume on each of the four channels
- The beltpack master volume
- The volume of the line-in feed.

5.2.1 Configuring the beltpack channel volumes and master volume

Each of the four beltpack channel volume levels is configurable separately.

Note: *You can only change volume levels on keys that have been configured.*

To configure a channel volume:

1. To enter the beltpack menu, press and hold the Menu key.
2. Turn either rotary control clockwise to highlight Vol Level Ctrl, and press the Menu Select key (D). The Volume Level Control screen appears:

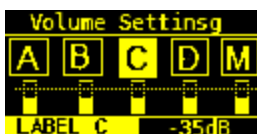

Use the left-hand rotary control to select the required channel, or select M for the master volume

Use the right-hand rotary control to adjust the volume level. The default is 0dB for channel audio, and -9.6dB for master volume.

The volume level appears in the footer.

To confirm the selection, press the Menu Select key (D).

5.2.2 Configuring the volume level of the line input

You can configure the volume of an audio line input:

1. To enter the beltpack menu, press and hold the Menu key.
2. Turn either rotary control clockwise to highlight Line In Vol Lvl, and press the Menu Select key (D).
3. Use either rotary control to select between -15 dB to 6dB
4. To confirm the selection and exit the menu screen, press the Menu Select key (D).

5.2.3 Configuring the rotary controls

You can configure the rotary controls on the beltpack to either:

- Control the volume of the audio on keys A and B
 - Control the master volume of the beltpack audio.
1. To enter the beltpack menu, press and hold the Menu key.
 2. Turn either rotary control clockwise to highlight Vol Operation, and press the Menu Select key (D).
 3. Use either rotary control to select between:
 - Talk Key
 - Master
 4. To confirm the selection and exit the menu screen, press the Menu Select key.

5.3 Configuring the beltpack headset

You can configure the following headset settings:

- Headset autodetect
- Headset sidetone level
- Headset limiter

The menus that appear depend on the menu access level. See **Setting full menu access on page 43**.

5.3.1 Setting headset autodetect

Use this setting to allow the beltpack to automatically detect when you plug in a headset, and route the audio to the headset.

Note: *To use this feature, first set Mic Type to Auto. See **Setting the microphone type on page 39**.*

1. To enter the beltpack menu, press and hold the Menu key.
2. Use the rotary and Menu Select keys to select Settings > Headset Options > Auto Detect.
3. Use either rotary control to select between:
 - On
 - Off
4. To confirm the selection and exit the menu screen, press the Menu Select key (D).

5.3.2 Setting the sidetone level

Use this setting to set the level of the sidetone. You can either set the sidetone to a fixed level, or choose to have the sidetone track the master volume level. To set sidetone to a fixed level:

1. To enter the beltpack menu, press and hold the Menu key.
2. Use the rotary and Menu Select keys to select Settings > Headset Options > Sidetone > Sidetone Level.
3. Use either rotary control to select the sidetone level between -70dB and 0dB.
4. To confirm the selection and exit the menu screen, press the Menu Select key.

5.3.3 Setting the headset limiter

Use this setting to limit the incoming headset audio level to prevent excessive sound levels.

1. To enter the beltpack menu, press and hold the Menu key.
2. Use the rotary and Menu Select keys to select Settings > Headset Options > Limiter.
3. Use either rotary key to select the limiter level between -12 and 8dB. The default is 0dB.
4. To confirm the selection and exit the menu screen, press the Menu Select key (D).

5.4 Configuring the beltpack microphone

You can configure the following microphone settings:

- Microphone type
- Microphone echo cancellation

The menus that appear depend on the menu access level. See **Setting full menu access on page 43**.

5.4.1 Setting the microphone type

Use this setting to specify the type of microphone you are using. You can also allow the beltpack to automatically detect what kind of microphone is present.

1. To enter the beltpack menu, press and hold the Menu key.
2. Use the rotary and Menu Select keys to select Settings > Mic Options > Mic Type.
3. Use either rotary control to select between:
 - Automatic (default)
 - Electret
 - Dynamic Unbalanced
4. To confirm the selection and exit the menu screen, press the Menu Select key (D).

Note: *If automatic headset detection is ON:*

- Dynamic headset is detected if microphone impedance is between 90 – 320 Ohms
- Electret headset is detected if microphone impedance is between 1.3 – 6.5 kOhms.

5.4.2 Setting the microphone echo cancellation

Use this setting to improve the microphone audio quality.

1. To enter the beltpack menu, press and hold the Menu key.
2. Use the rotary and Menu Select keys to select Settings > Mic Options > Echo Cancellation.
3. Use either rotary control to select between:
 - On
 - Off (default)
4. To confirm the selection and exit the menu screen, press the Menu Select key.

5.5 Configuring the beltpack display and LEDs

You can configure the following display options:

- Display brightness level
- Display dim timeout
- Display off timeout

5.5.1 Setting the display and LED brightness

Use this setting to control the brightness of the display. The beltpack automatically dims after a timeout period if no key is used or there is no incoming call or call alert. You can adjust the timeout period.

When the beltpack is dimmed, the display goes off after a timeout period if no key is used or there is no incoming call or call alert. You can adjust the timeout period.

1. To enter the beltpack menu, press and hold the Menu key.
2. Use the rotary and Menu Select keys to select Settings > Display Options > Brightness Level
3. Use either rotary control to select the dim level between 1 and 5 (default).
4. To confirm the selection and exit the menu screen, press the Menu Select key.

5.5.2 Setting the display dim timeout

Use this setting to determine when the beltpack display will dim if no key is used or there is no incoming call or call alert.

1. To enter the beltpack menu, press and hold the Menu key.
2. Use the rotary and Menu Select keys to select Settings > Display Options > Dim Timeout
3. Use either rotary control to select the dim level between Off and 120 seconds (default).
Setting the dim timeout to Off disables the timeout function.
4. To confirm the selection and exit the menu screen, press the Menu Select key.

5.5.3 Setting the display off timeout

Use this setting to determine when a dimmed beltpack display will switch off.

1. To enter the beltpack menu, press and hold the Menu key.
2. Use the rotary and Menu Select keys to select Settings > Display Options > Off Timeout
3. Use either rotary control to select the dim level between Off and 120 seconds (35 second default).
Setting the display off timeout to Off disables the timeout function.
4. To confirm the selection and exit the menu screen, press the Menu Select key (D).

5.6 Configuring the beltpack alarm options

You can configure the following alarm options:

- Low battery alarm
- Low battery alarm threshold
- Out of range alarm
- Call alert mode

Note: See 4.2.3 *Beltpack headset tones/alerts for a description of tones and alerts.*

5.6.1 Setting the low battery alarm

Use this setting to determine how the beltpack behaves when battery power is low. You can set the following types of alarm:

- Audio warning
- Vibrate
- Audio warning and vibrate
- Off

1. To enter the beltpack menu, press and hold the Menu key.
2. Use the rotary and Menu Select keys to select Settings > Alarm Options > Alarm Mode.
 - Use either rotary control to select between:
 - Vibrate & Audio (default)
 - Vibrate Only
 - Audio Only
 - Off
3. To confirm the selection and exit the menu screen, press the Menu Select key (D).

5.6.2 Setting the low battery alarm threshold

Use this setting to determine the battery power level that triggers the low battery alarm.

1. To enter the beltpack menu, press and hold the Menu key (D).
2. Use the rotary and Menu Select keys to select Settings > Alarm Options > Low Battery Threshold.

3. Use either rotary control to select a value between 0 and 100%.
4. To confirm the selection and exit the menu screen, press the Menu Select key (D).

5.6.3 Setting the out of range alarm

Use this setting to determine what kind of alarm the beltpack issues when it moves out of range of a transceiver. You can set the following alarms:

- Audio on
 - Off
1. To enter the beltpack menu, press and hold the Menu key.
 2. Use the rotary and Menu Select keys to select Settings > Alarm Options > Out of Range Alarm.
 3. Use either rotary control to select between:
 - Audio only
 - Off
 4. To confirm the selection and exit the menu screen, press the Menu Select key (D).

5.6.4 Setting the call alert

Use this setting to determine what kind of alert the beltpack issues when it receives an incoming call. You can set the following alerts:

- Audio warning
 - Vibrate
 - Audio warning and vibrate
 - Off
1. To enter the beltpack menu, press and hold the Menu key.
 2. Use the rotary and Menu Select keys to select Settings > Alarm Options > Call Alert Mode.
 3. Use either rotary control to select between:
 - Vibrate & Audio (default)
 - Vibrate Only
 - Audio Only
 - Off
 4. To confirm the selection and exit the menu screen, press the Menu Select key (D).

5.7 Selecting the beltpack role default set

Use this setting to set the beltpack configuration to the default settings defined in the EHX configuration map for that role.

1. To enter the beltpack menu, press and hold the Menu key.
2. Use the rotary and Menu Select keys to select Settings > Role Default Set.
3. Use either rotary control to select between:
 - On (default)
 - Off
4. To confirm the selection and exit the menu screen, press the Menu Select key (D).

5.8 Selecting the beltpack administration

You can select the following administration settings:

- System pairing mode
- Full menu access
- System sync mode

5.8.1 Enabling OTA registration mode

Use this setting to enable or disable system pairing mode. Enable this mode if you want to register a beltpack over the air.

1. To enter the beltpack menu, press and hold the Menu key.
2. Use the rotary and Menu Select keys to select Settings > Admin Options. You will be prompted to enter a four digit code. The default code is 4632.
3. Select Enable Pair Mode.
4. Use either rotary control to select between:
 - Disable
 - Enable
5. To confirm the selection and exit the menu screen, press the Menu Select key (D).

5.8.2 Setting full menu access

Use this setting to override the menu access for the beltpack role. The following menu access levels apply:

- None
- Basic
- Normal
- Advanced

If this setting is not enabled, the menu access is set in the EHX software to one of the above four levels. When it is enabled, the beltpack has full menu access.

Note: *If you change this setting, it will apply until the beltpack role changes, or the beltpack is power cycled.*

1. To enter the beltpack menu, press and hold the Menu key.
2. Use the rotary and Menu Select keys to select Settings > Admin Options. You will be prompted to enter a four digit code. The default code is 4632.
3. Select Full Menu Access.
4. Use either rotary control to select between:
 - Disable (default)
 - Enable

5.8.3 Setting system sync mode (not currently available)

Use this setting to make transceiver synchronization readings.

1. To enter the beltpack menu, press and hold the Menu key.
2. Use the rotary and Menu Select keys to select Settings > Admin Options. You will be prompted to enter a four digit code. The default code is 4632.
3. Select System Sync.
4. Use either rotary control to select the transceiver group to synchronize.

5.9 Setting the listen again option

Use this setting to configure an option to allow you to play back an incoming message. When Listen Again is active, if you tap the Menu key on the beltpack, the last received message is played back. You can select the length of the recorded message, and also how long the message is stored on the beltpack before automatic deletion. To play back a recorded message, press the Menu button.

To select the length of the recording:

1. To enter the beltpack menu, press and hold the Menu key.
2. Use the rotary and Menu Select keys to select Settings > Listen Again Opt > Recording Time.
3. Use either rotary control to select a value between Off and 15 seconds.

To determine how long the message is stored:

1. To enter the beltpack menu, press and hold the Menu key.
2. Use the rotary and Menu Select keys to select Settings > Listen Again Opt > Auto Delete Time.
3. Use either rotary control to select a value between Off and 240 minutes.

5.10 Control audio on keys C & D (beltpack)(advanced menu option only)

Pressing the menu button on your beltpack can trigger Listen Again. However, a quick tap on the menu button can also be configured to allow volume on keys C & D to be adjusted by the rotary controllers.

The default setting for this option is Listen Again.

To control volume on keys C & D using menu keypad:

1. Press and hold the menu button to enter menu mode.
2. Navigate to Settings/Menu key oper using the rotary controllers
3. Press key D to select menu key operation option
4. Scroll down to Switch to Vol Ctrl using rotary controllers
5. Press key D to select option.

You can now control audio volume on keys C & D using the rotary controllers (the same as you do on keys A & B) by giving the menu key on the beltpack a quick tap, instead of using this action to trigger Listen Again. This menu key behavior option can also be set in the EHX software.

Note: *This mode has a 5 second inactive time-out, after which time the rotary controllers will revert to controlling volume on keys A & B. To re-activate this mode in order to adjust C & D, use another quick tap of the menu key. To switch quickly between A & B and C & D, tap the menu key to toggle.*

5.11 Accessing beltpack information

You can access a list of beltpack information, including battery and fault-finding information.

1. To enter the beltpack menu, press and hold the Menu key.
2. Use the rotary and Menu Select keys to select Information.

You can read the following information:

Item	Value
Beltpack role	Role name
SW (software)	Version number
Beltpack. ID (beltpack identity)	ID number
RFP (Remote Fixed Part – transceiver)	ID number
Regional (DECT frequency area)	DECT region. For example, US_DECT.
Battery Level	Percentage charge, hours of use

5.12 Setting display mode

You can select between two display modes: Intercom mode and Partyline mode.

Note: *You can only access this option if you have advanced menu access.*

1. To enter the beltpack menu, press and hold the Menu key.
2. Use the rotary and Menu Select keys to select Display Mode.
3. Use either rotary control to select between:
 - Intercom mode
 - Partyline mode

5.13 Setting system connect

Use this option to connect to a transceiver.

1. To enter the beltpack menu, press and hold the Menu key.
2. Use the rotary and Menu Select keys to select System Connect.

A list of available systems appears on the beltpack screen.
3. Use the rotary control to select a system.

5.14 Enabling over the air (OTA) registration mode from a beltpack

In some circumstances you may need to enable registration of beltpacks without having access to a matrix or computer. In this case it can be done from a beltpack.

The beltpack needs to be previously registered and connected. You need the Menu Access code, available from Eclipse EHX. (The default code is 4632). To view or change the Menu Access code select Configuration > Preferences. The following screen appears:

DTMF Passcodes

Passcode 1:

Passcode 2:

Passcode 3:

Passcode 4:

Passcode 5:

Passcode 6:

Passcode 7:

Passcode 8:

Menu Access Code (Panel and FreeSpeak II Beltpack)

Enter the code that users must enter to access PIN protected menus.

Code: 

Features Passcode

Enable Production Maestro Pro by entering the 16 digit passcode obtained from your distributor below:

1. From the registered, connected beltpack press and hold the MENU button for 2 seconds to enter the menu options.
2. Go to Settings > Admin Options.
3. Enter the Menu Access code using the left and right hand rotary controllers on the beltpack.
If the Menu Access code is successful, the beltpack will display the Enable Pair Mode screen.
4. Press the D key on the beltpack to select this option.
5. A confirmation screen will appear. Select Y to confirm.
The system will now be open for registration for 2 minutes.
6. From the beltpack to be registered, follow the registration procedure. See **Registering the beltpack on page 29**.

5.15 Performing a site survey

Note: *You can only access this option if you have advanced menu access.*

You can survey an intercom installation to determine how many FreeSpeak II transceivers are present. You can do this in two ways:

- Connecting to a system and detecting all FreeSpeak II transceivers connected to that system
 - Performing a survey with no system connection. All FreeSpeak II transceivers are detected regardless of which system they are connected to.
1. To enter the beltpack menu, press and hold the Menu key.
 2. Use the rotary and Menu Select keys to select Site Survey.

6 Operating the FS II IP Transceiver (IPT)

This chapter describes how to use the FreeSpeak II IP transceiver.

For information about operating the FS II Transceiver that connects to an E-Que card, see **Operating the FS II Transceiver on page 71**.

The FS II IP Transceiver (IPT) forms the transmission link between the FS II beltpacks and the matrix. It offers internal omnidirectional (all directions/spherical) coverage. Multiple units are used to support the beltpacks and to create larger, customized coverage areas. Each transceiver is connected to the E-IPA-HX card on the matrix via an AES67 connection.

The unit has two methods of fixing:

- Four screw points for mounting on a flat surface.
- Two microphone stand connectors, 3/8 in and 5/8 in.

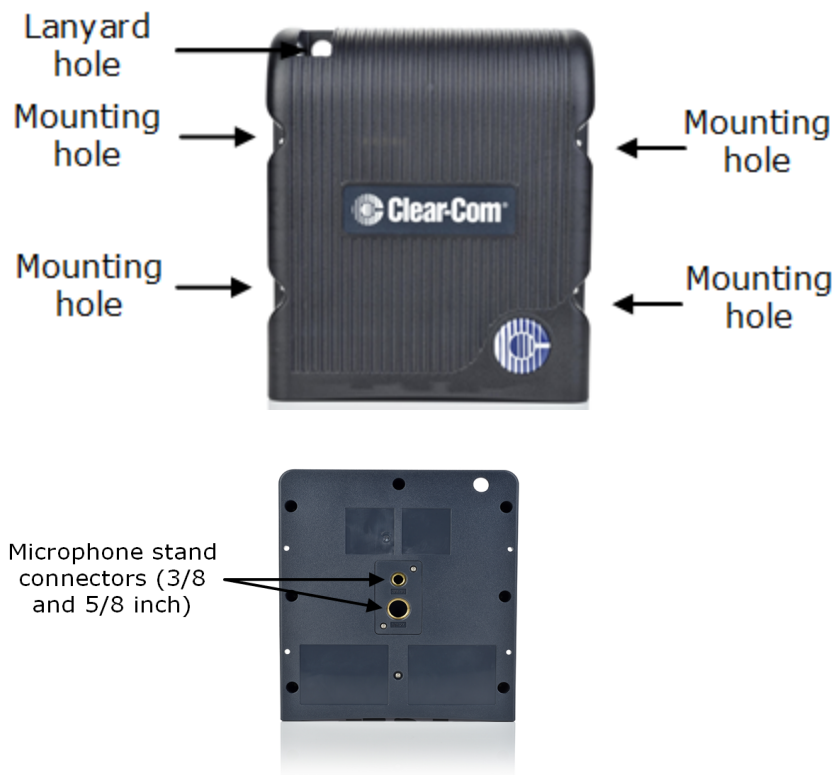

6.1 IP rating (Protection Marking)

The transceiver has an IP rating of IP53 so it can be mounted outside and will be resistant to weather conditions.

6.2 FS II IP Transceiver connector panel

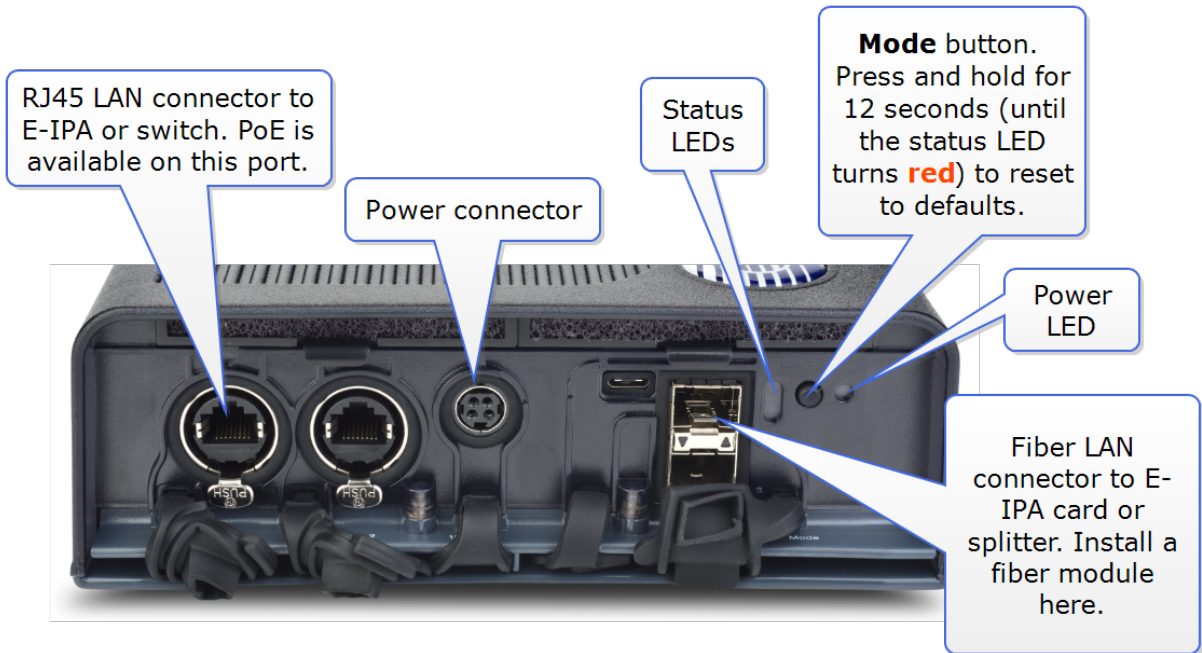

Warning: do not connect more than one IP port to your IP network. This may lead to a broadcast storm and could seriously degrade the performance of your network.

6.3 IP Transmitter LEDs



Transceiver state	Status LED (LED 1 shows normal operating mode)
Power on test failure	LED 2 red 2 Hz
Temperature	LED 1 red 2 Hz: overheat. LED 1 light blue 2 Hz: underheat
No data connection	LED 1 white 2 Hz
Initializing AES67/locking to PTP	LED 1 purple 2 Hz
Acquiring DECT sync	LED 1 amber 2 Hz
Transceiver online and ready for	LED 1 solid amber

Transceiver state	Status LED (LED 1 shows normal operating mode)
beltpack connection	
Standalone (rigging) mode	LED 2 double flash amber: device is in Standalone mode. LED 1: normal indication, solid amber: standalone transceiver is online and ready for beltpacks LED 1 and 2 solid amber: device has entered standalone mode, release mode button.
Mode indicators (LED 2)	Press and hold the Mode button: >3 secs: LED 2 white (state 1) >6 secs: LED 2 green (state 2) >9 secs: LED 2 amber (state 3) >12 secs: LED 2 red (state 4) Press and hold the Mode button until LED 2 is red to reset device to default (DHCP).

6.4 IP Transceiver fans and filters

The IPT operating temperature is 0 to 45 C in shaded conditions.

Each transceiver contains two fans which activate when the IPT internal temperature reaches 55 C. If the internal temperature reaches 60 C, LED 1 will flash red at 2 Hz.

You should periodically check that the fans function correctly, and if necessary replace them.

Note: *If a fan fails, LED 1 flashes red at 4 Hz.*

Each transceiver contains two internal filters and one external filter to protect the device from dust and other atmospheric debris.

You should periodically clean the filters with warm water and let them dry. Replace them if they are damaged.

Clear-Com recommends that you clean the internal filters every 1 to 2 months, and that you clean the external filter every 18 to 24 months.

For a list of spare parts, including the fans and filters, see **Spare parts on page 70**

To change the IPT fans and filters, see the diagrams below.

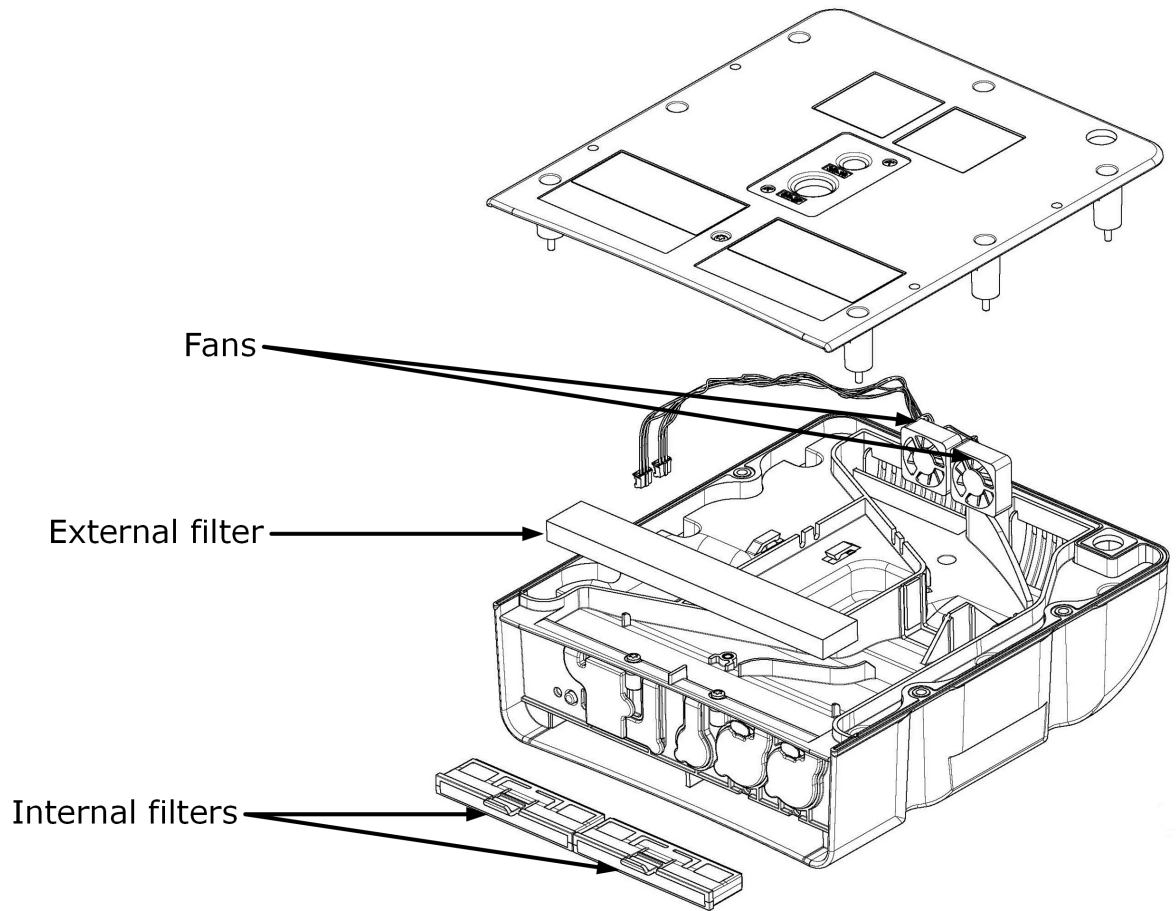

Fans

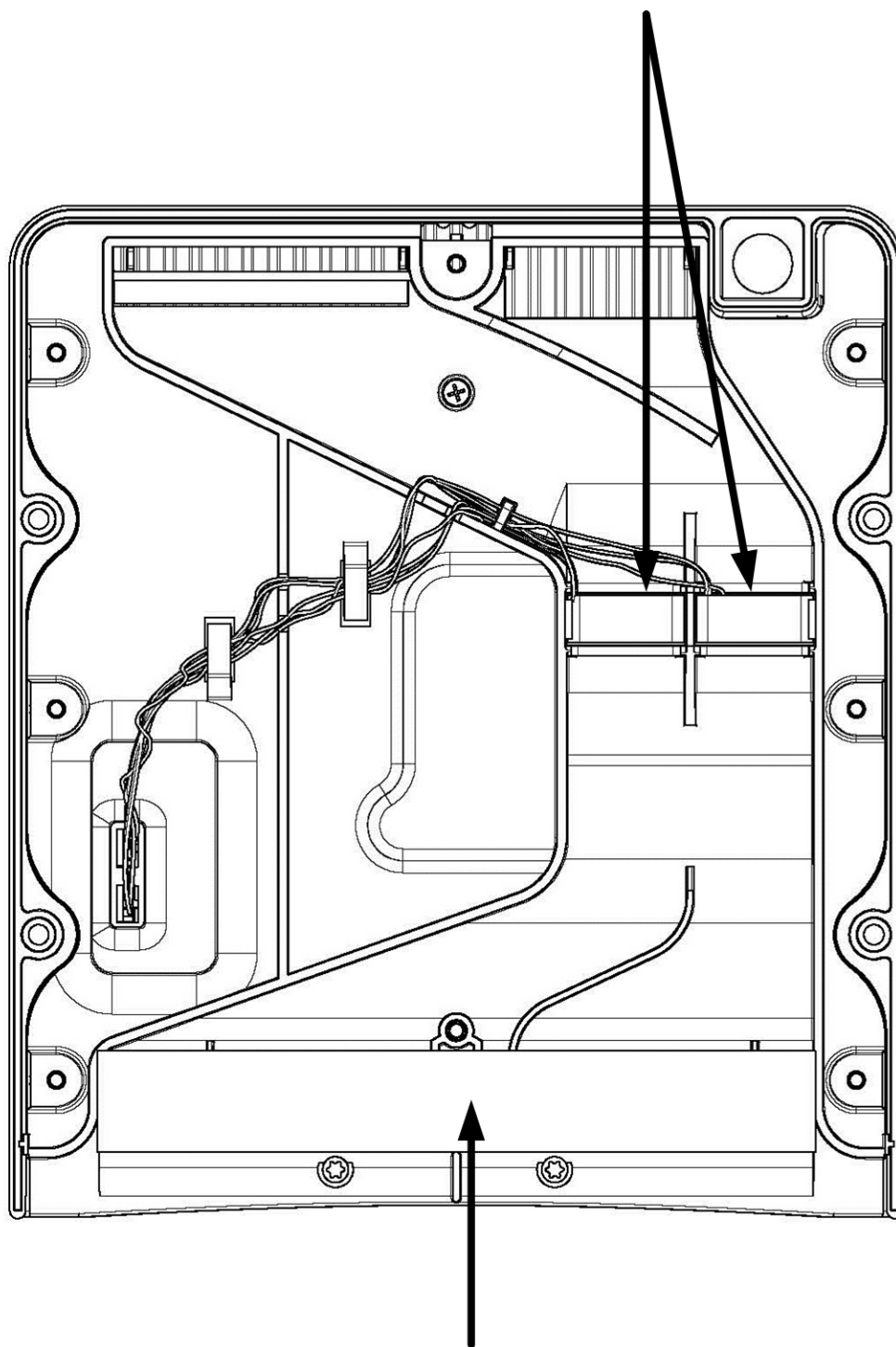

External
Filter

6.5 Reset the IPT to default

To reset the IP Transceiver to default:

1. Press and hold the Mode button for at least 12 seconds.

This will reset the IP Transceiver to DHCP mode, and remove any stored diagnostics.

Press and hold the Mode/reset button. Hold the button until the status light turns **solid red** (12 secs). Release the button. The device will reboot and reset to default settings.

Note: Default IP setting = **DHCP**



The Admin and the audio (AES67) IP addresses are reset to DHCP. Reset can take up to 5 minutes.

6.6 Transceiver standalone mode

You can use the standalone mode to connect the IPT to two belt packs with full duplex audio. This is useful for performing an initial site survey when the IPT has no matrix connection. In standalone mode, for convenience, you can use a USB battery pack (5V, 3A) to power the transceiver.

To enable standalone mode:

1. Press and hold the Mode button while simultaneously powering the IPT with the USB battery pack.

Both LEDs will turn solid yellow when standalone mode is enabled. It takes from 2 to 3 minutes for the IPT to reach standalone mode.

Note: While the IPT is in standalone mode, LED 2 will flash amber.

6.7 Connecting the FS Transceivers to a matrix

The FS IP transceiver connects to an E-IPA-HX card in an Eclipse HX Digital Matrix.

You can connect transceivers to one of the LAN ports (LAN 1 - 6). For a fiber connection, connect the IPT to LAN 5 or 6. In the EHX configuration software, LAN 3 is the default AES67 connection.

Warning: Do not connect more than one cable from the E-IPA card to the same LAN/VLAN. This may lead to a broadcast storm and could seriously degrade the performance of your network.

- Clear-Com matrices can contain more than one E-IPA card. However, only one E-IPA-HX card in a matrix can connect to FreeSpeak II beltpacks.
- Transceivers cannot be added to the matrix until at least one beltpack is configured.
- Each E-IPA-HX card can connect to up to 64 IP Transceivers (IPT). Each transceiver can connect up to 10 beltpacks.
- The total number of beltpacks depends on your E-IPA-HX license.

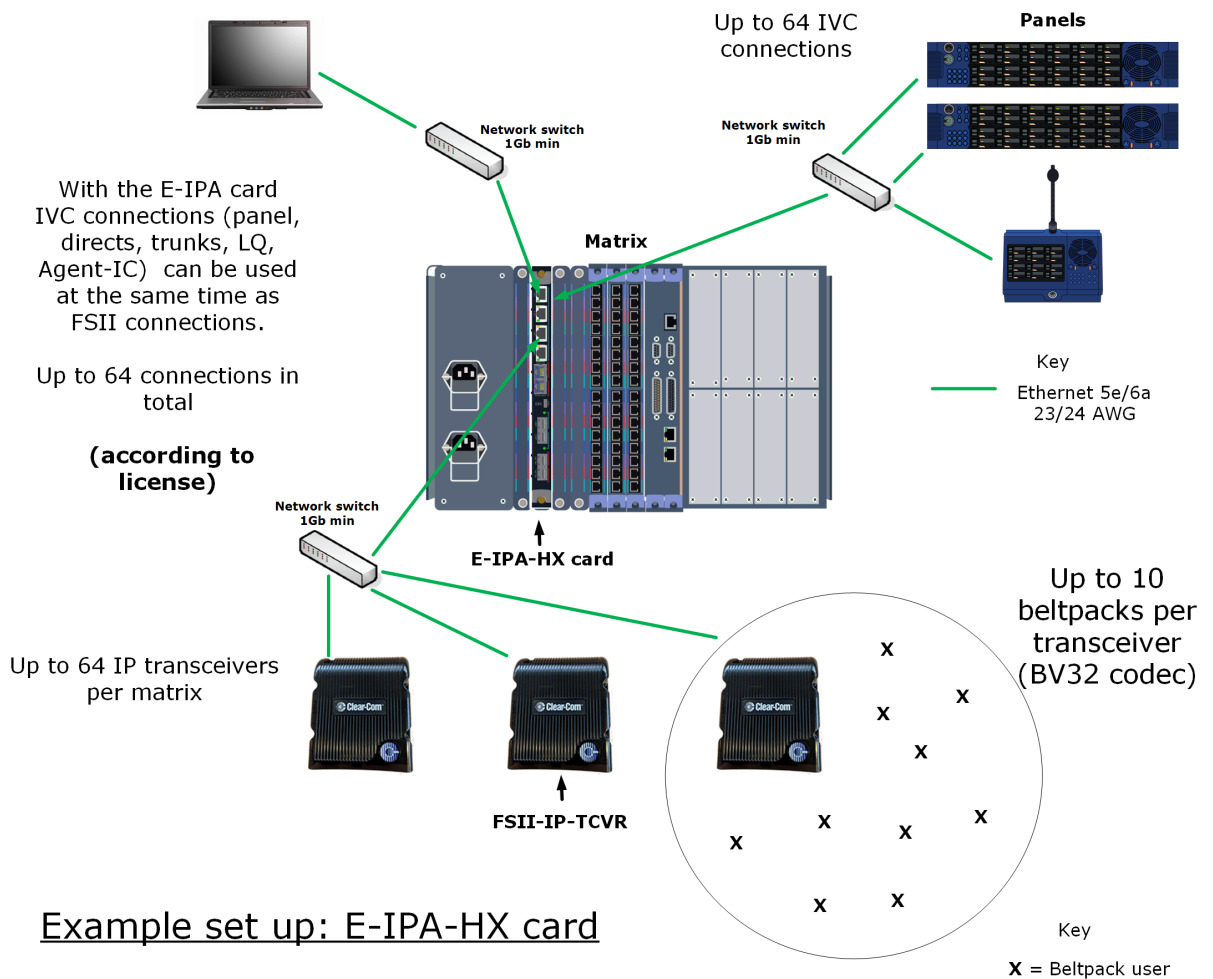

Reccomendation:

- The IPT transceivers have a higher than average requirement for network timing accuracy. For this reason it is advisable to use different VLANs to route Admin/IVC traffic and AES67 IPT traffic.

Rules:

- If you are using more than one connector on your E-IPA card for Admin/IVC and AES67 then they must connect to different switches or VLANs.
- If you separate Admin and IVC traffic then they must be on different VLANs.

Note: *The bandwidth usage per IP transceiver is ~12Mbps.*

Warning: If you change the IP address of the AES67 ports (transceiver or E-IPA matrix card), the devices will reset automatically. Reset can take up to five minutes..

When connecting the E-IPA-HX card to the IP transceiver over your network certain scenarios will work while others do not. This is down to the way the E-IPA card routes audio and data between ports and processors.

Example set ups:

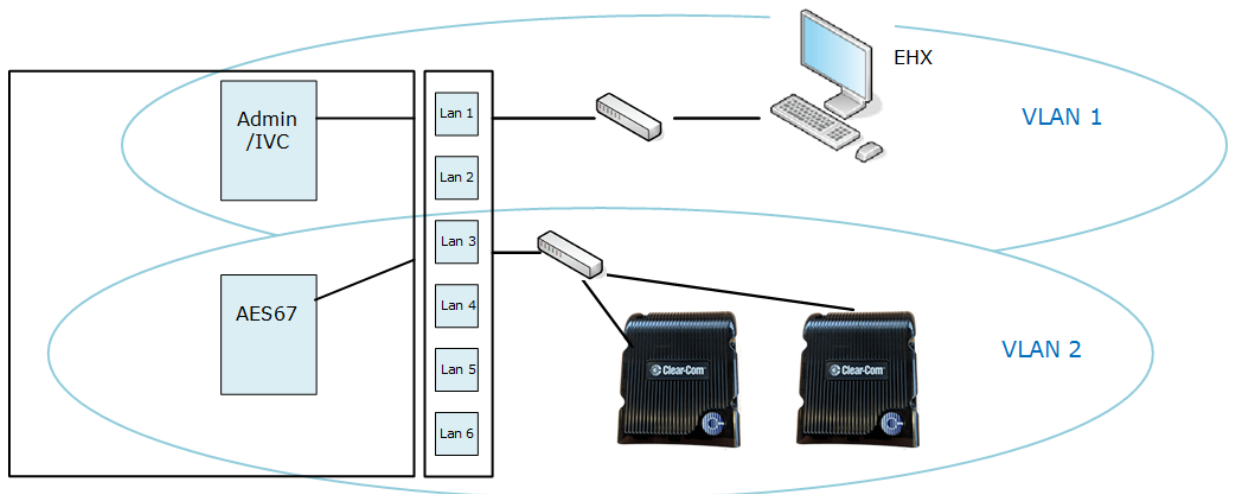

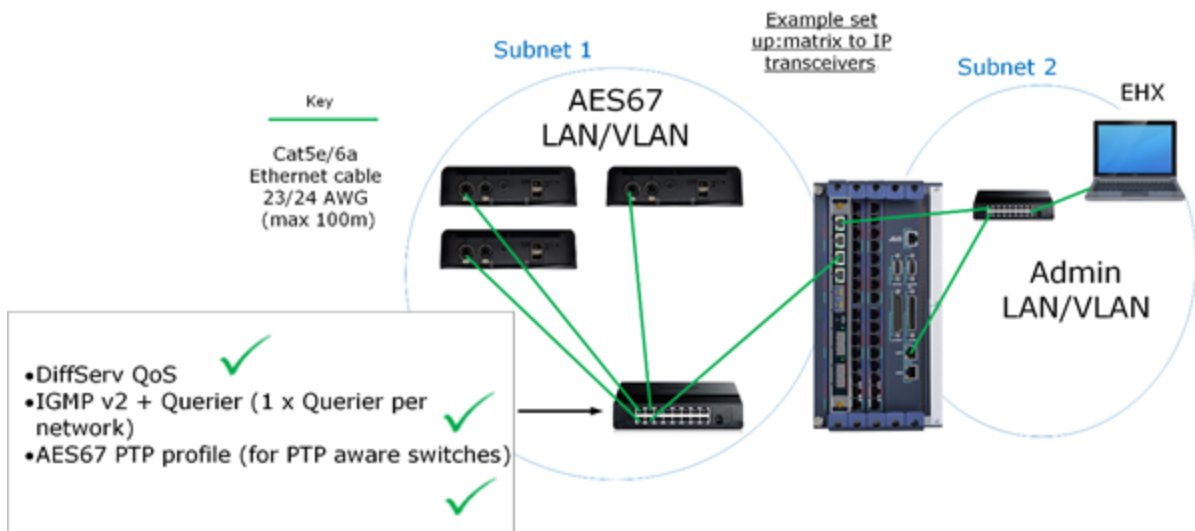
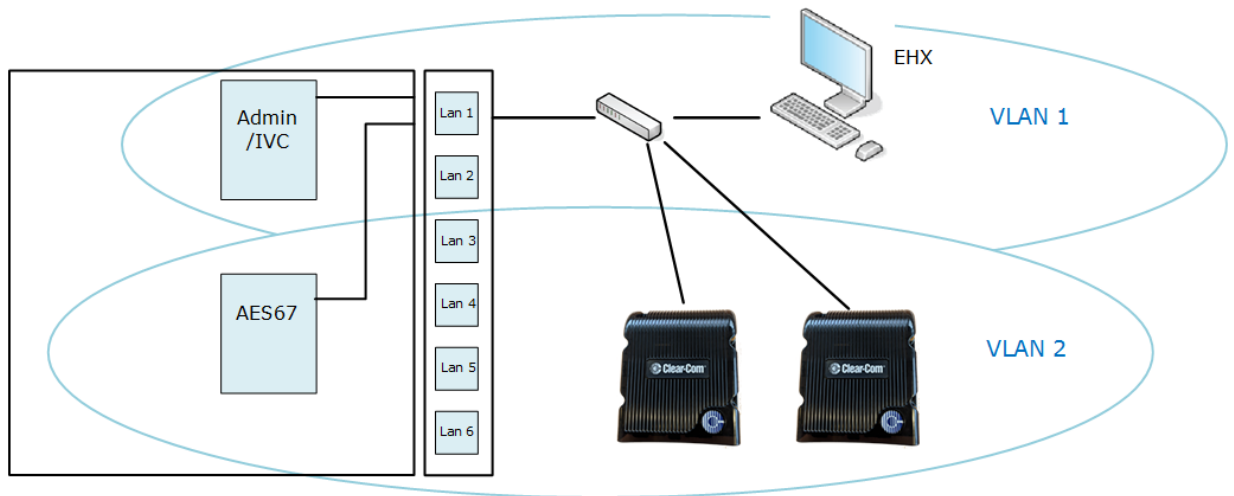

6.7.1 Network setup for the IPT

Bear in mind the following network considerations. For more information, refer to the Clear-Com network recommendations document.

- AES67 connections to the IP transceiver can be put on ports 1-6 (RJ45 or Fiber). Default: LAN 3.
- Clear-Com recommends that AES67 traffic has its own VLAN.
- If there is no DHCP server, AES67 connections will use the link-local range of IP addresses (169.254.XXX.XXX).

- When configuring an AES67 network, the network switch needs to have DiffServ Quality of Service (QoS) switched on.
- Internet Group Management Protocol (IGMP) snooping needs to be switched on, with at least one IGMP querier.
- The network must be 1Gbps. A 100Mbps network will not support the amount traffic the card can generate, and will not deliver the required PTP accuracy.
- The Multicast enabled switch must be ON.
- Try to keep the number of layer 2 hops between PTP master and slave (for example, IP Transceiver) as low as possible (no more than three). If there are more than three, you require switches that support PTP, for example transparent clocks or boundary clocks.
- Use DHCP (the default setting) for fast and easy setup of the devices. If no DHCP server is present, IPTs will self-assign an IP address in the Link-Local range.

The screen below shows the E-IPA-HX card properties screen.

Note:

If you need to use static IP addressing for your transceivers, see Static configuration in this document.

The screenshot shows the 'E-IPA-HX Card Properties' configuration window. At the top, there is a toggle for 'Use IVC settings for Admin connection' which is turned on. Below this is a dropdown for 'E-IPA-HX Port License' set to 'E-IPA-16-HX' and a button 'Open in browser'. The main configuration area has two tabs: 'Admin and IVC' and 'AES-67'. The 'AES-67' tab is active, showing a 'Rear Connection' dropdown set to 'LAN 3'. Below this are fields for 'DHCP Enabled' (checked), 'IP Address' (169.254.10.107), 'Subnet mask' (255.255.0.0), and 'Default gateway' (255.255.255.255). A 'Close' button is at the bottom right. Three callout boxes provide additional information: one points to the 'AES-67' tab, another points to the 'Rear Connection' dropdown, and a third points to the 'IP Address' field.

Click here to configure the IP address of the AES67 port

Select from ports 1 - 6. AES67 is usually configured on a separate LAN connection from Admin and IVC

When in DHCP mode, link local is used if there is no DHCP server

6.8 Cabling the IP transceivers

Run standard Ethernet cable from one of the LAN connectors on the back of the E-IPA-HX card to either LAN 1 or LAN 2 on the IP Transceiver via an IP switch.

6.9 Configuring the E-IPA-HX card for FreeSpeak II

Note: For more information about using the EHX configuration software to setup and configure the IP transceiver, see the EHX Configuration Software User Guide.

6.9.1 Set card properties

Configure the network settings in Card Properties. (add graphic?)

6.9.2 Add beltpacks

When using FreeSpeak II on E-IPA-HX, each beltpack takes up a matrix port. Select the number of beltpacks you require.

1. Navigate to Cards and Ports and select the E-IPA-HX Card slot.
2. Click **+Port**. The following screen appears.

The screenshot shows the configuration interface for an E-IPA-16-HX card. The fields are as follows:

- E-IPA-16-HX** (Card Name)
- Available Ports:** 16
- Port Function:** Wireless Beltpack (selected from a dropdown)
- Label:** Label_0
- Auto generated label options:** (dropdown menu)
- Example label:** Label_0
- Characters to replace:** 0
- Seed value:** 0
- Description:** Wireless Beltpack
- Quantity:** 6
- Buttons:** Add, Close

Callouts point to the following elements:

- Select Wireless Beltpack:** Points to the Port Function dropdown menu.
- Select the number of ports:** Points to the Quantity input field.
- Add:** Points to the Add button.

Note: If you are adding more than one port, you can enter values in the **Characters to Replace** and **Seed value** fields to automatically generate labels. For example if you enter **Label 0** in the **Label** field, and then enter **0** in the **Characters to replace** and **Seed value** fields, this will automatically generate labels called **Label 1**, **Label 2**, **Label 3** up to the specified number of labels.

3. Click **Add** to add the ports, and then **Close** to exit the screen.

Note: The ports that are allocated to beltpacks can be thought of as a pool of ports that can be used by any FreeSpeak beltpack. You only need to allocate for the number of beltpacks you intend to have connected to the system at any one time. No allocation for spare beltpacks is needed.

When at least one beltpack has been allocated to the card, you will see a **Beltpacks** button appear under **Hardware**. Click this button to configure beltpacks in the usual way. (Registration and Roles).

6.10 Adding transceivers

When at least one beltpack has been allocated to the card, you will see a **Transceivers** button appear under **Hardware**. Click this button to add and remove IP transceivers.

Two methods can be used for adding transceivers;

1. Offline configuration
2. Online configuration (the Discovery method).

6.10.1 Offline configuration

Use the **+ IP TCVR** button to add transceivers to your configuration (offline configuration).

To connect the matrix and the transceiver, input the transceiver mDNS Hostname or IP address into transceiver **Properties** and click **Apply Map to Matrix**.

Note: *The mDNS Hostname is on the label on the back of the Transceiver.*

Note: *Using mDNS hostname means that even if the IP Address is changed, the matrix will automatically re-connect with the new IP without an Apply Changes being required.*

Use the **- IP TCVR** button to remove transceivers from your configuration, then Apply Changes.

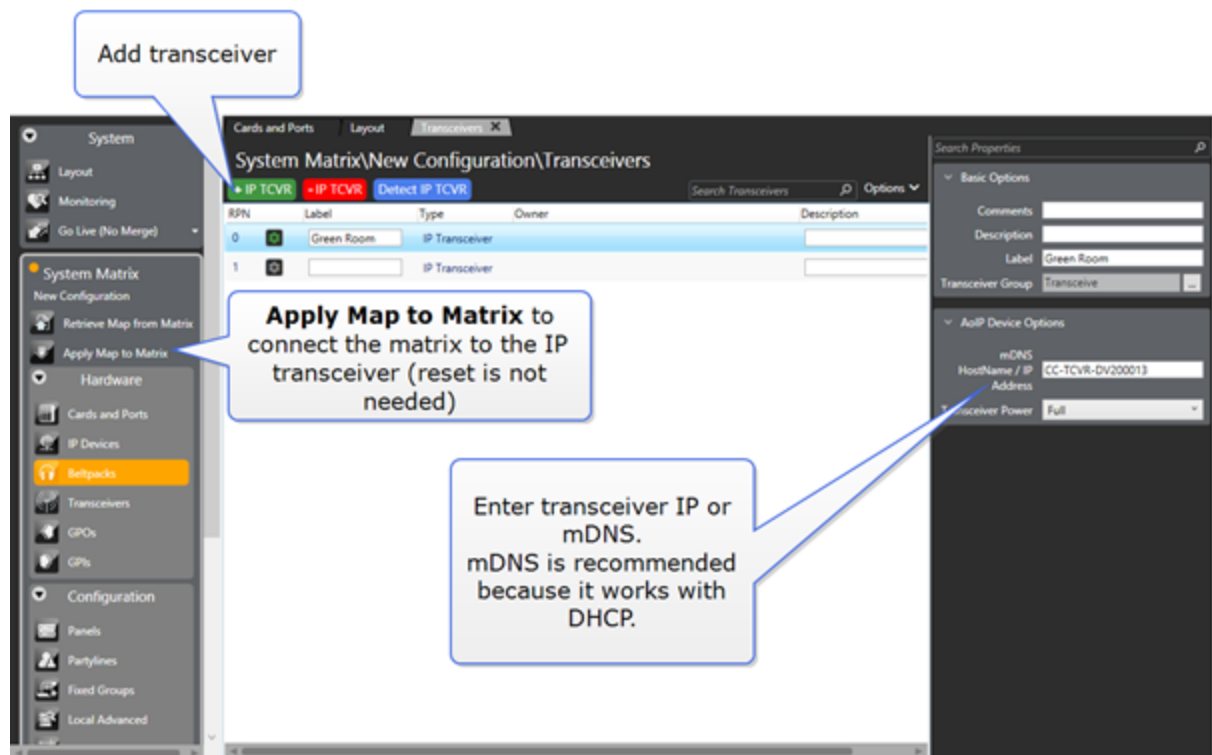

6.10.2 Online configuration

Use **Detect IP TCVR** to find the IPTs on the network (the AES67 interface of the E-IPA-HX card and the IPTs must be on the same network, and the EHX software must be on the same network as the IPA Admin port). By default, the E-IPA-HX is DHCP enabled, and the IPT is also by default in DHCP mode.

Note: *The Detect IP TCVR feature works if the IPTs are not on the same subnet, but connected to the same network, as the AES67 interface on the E-IPA-HX card. However, for connection between the transceiver and the card, the devices must be on the same subnet.*

Note: *If you reset an IPT to default settings, the device reverts to DHCP. To reset the IPT, press and hold the **Mode** button on the transceiver base until the status light turns red (approx 12 seconds).*

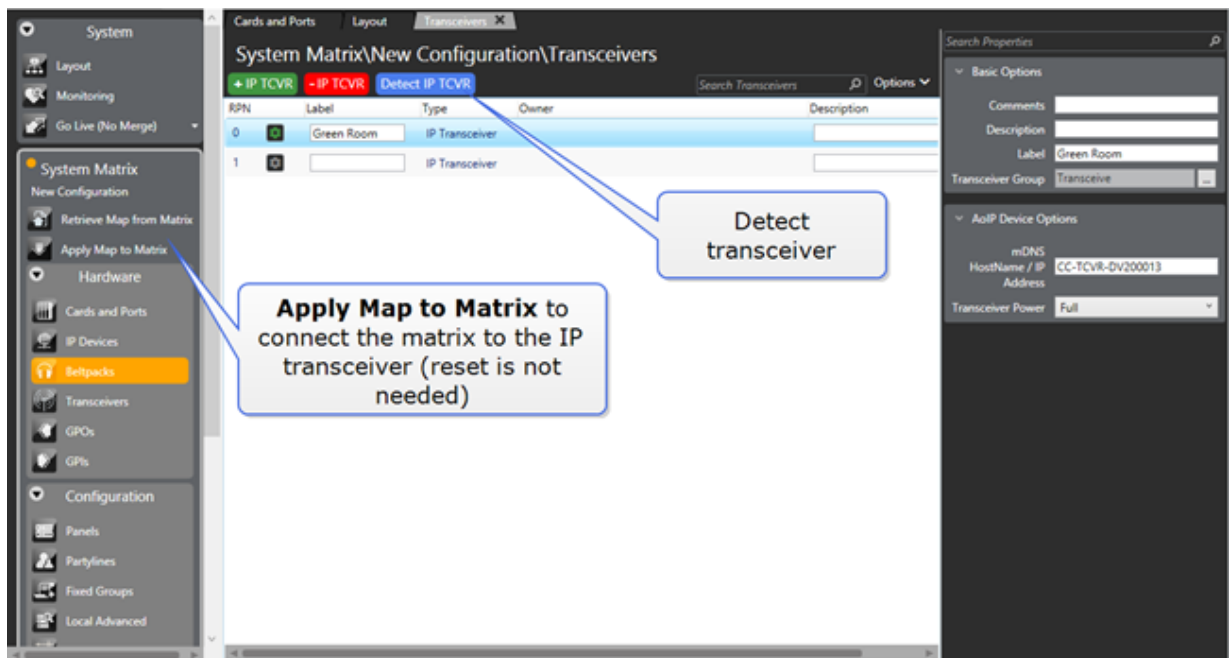

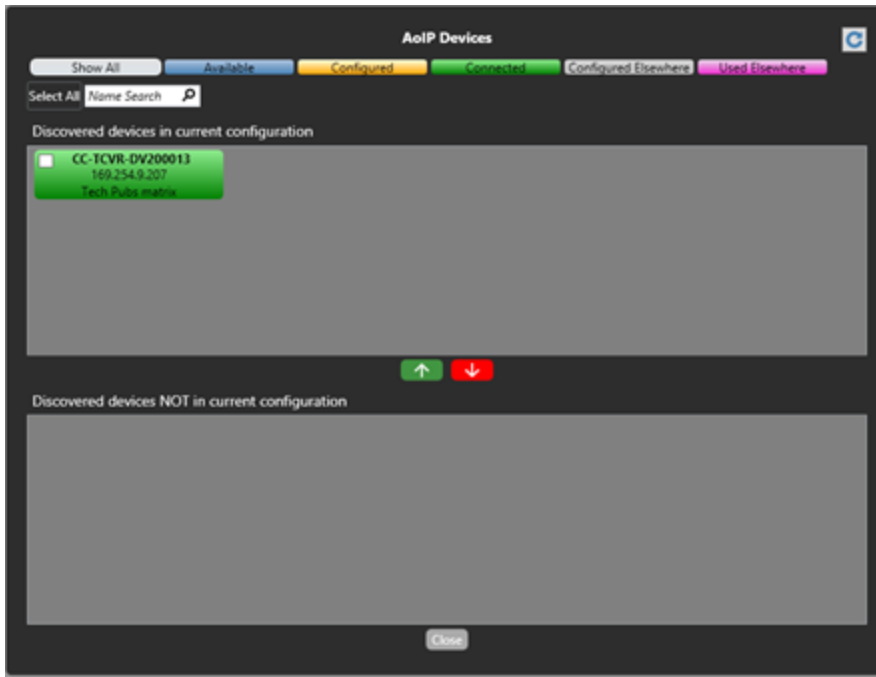

From the AoIP Devices screen, use the up and down arrows to add or remove matrices from your current configuration. **Apply Map to Matrix** when you are done.

The color of the detected transceiver indicates:

Blue: Transceiver is available.

Amber: Transceiver is configured, but not connected to the matrix. A download is required.

Green: Transceiver is connected to the matrix.

Gray: Transceiver is connected to another matrix, but it is not online.

Purple: Transceiver is already connected to another matrix.

6.10.3 Static configuration

By default, the E-IPA-HX card is DHCP enabled, and any IPTs are in DHCP mode. However, you can allocate static IP addresses for an IPT. If the IP AES67 Admin and AES67 Audio IP addresses are in DHCP mode, you must set them to static mode.

1. Navigate to **Hardware > Cards and Ports**, and then double-click the card slot containing the E-IPA-HX card. The Card Properties screen appears.

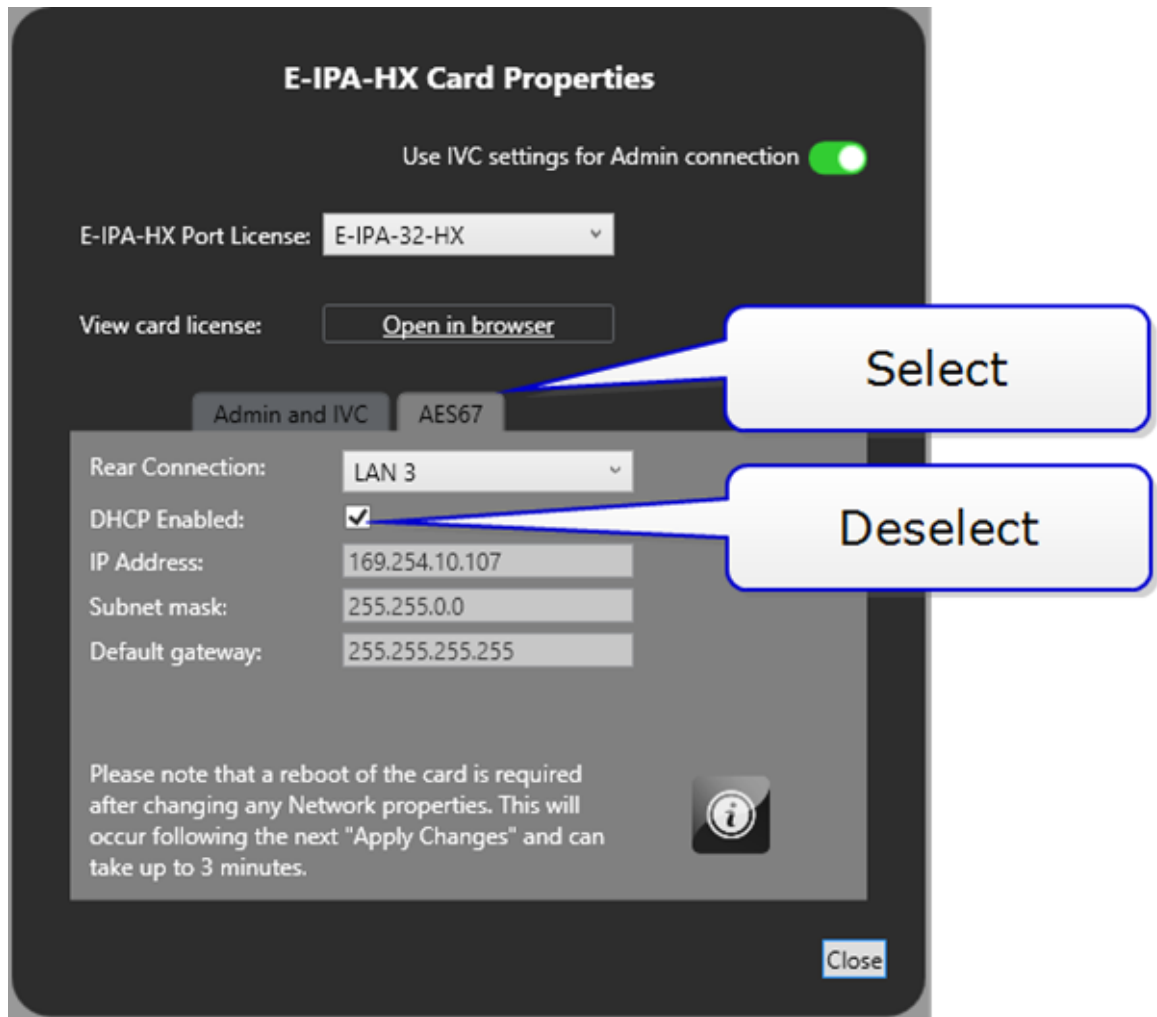

2. Select the **AES67** tab, and then deslect **DHCP Enabled**.
3. Enter the required static IP address, and then **Apply Changes**.
4. Click **Close**.
5. Navigate to **Hardware > Transceivers**.
6. Click the cog  icon for the required transceiver. The Transceiver Properties screen appears.
7. Select **Edit**, and then deselect **DHCP Enabled** for both AES67 Admin and AES67 Audio.

Note: You cannot mix DHCP and static IP addressing on the IPT.

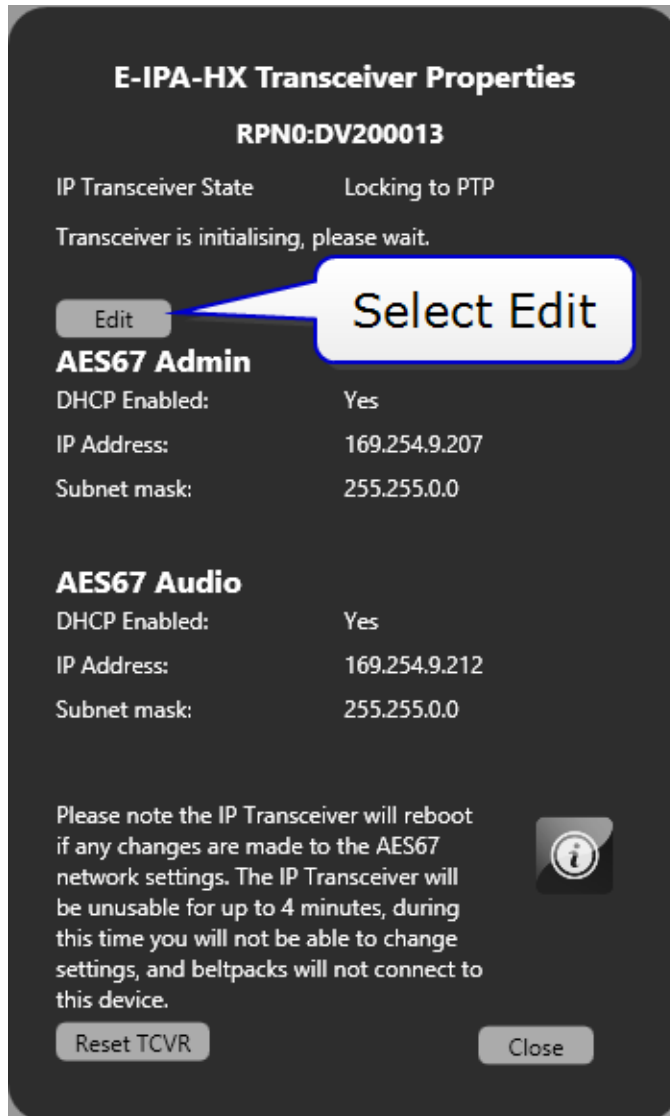

Note: The IP Transceiver must be connected.

8. Enter the required static IP addresses for AES67 Admin and AES67 Audio.

Note: You cannot set static IP addresses that are within the Link Local range (169.254.0.0 to 169.254.255.255)

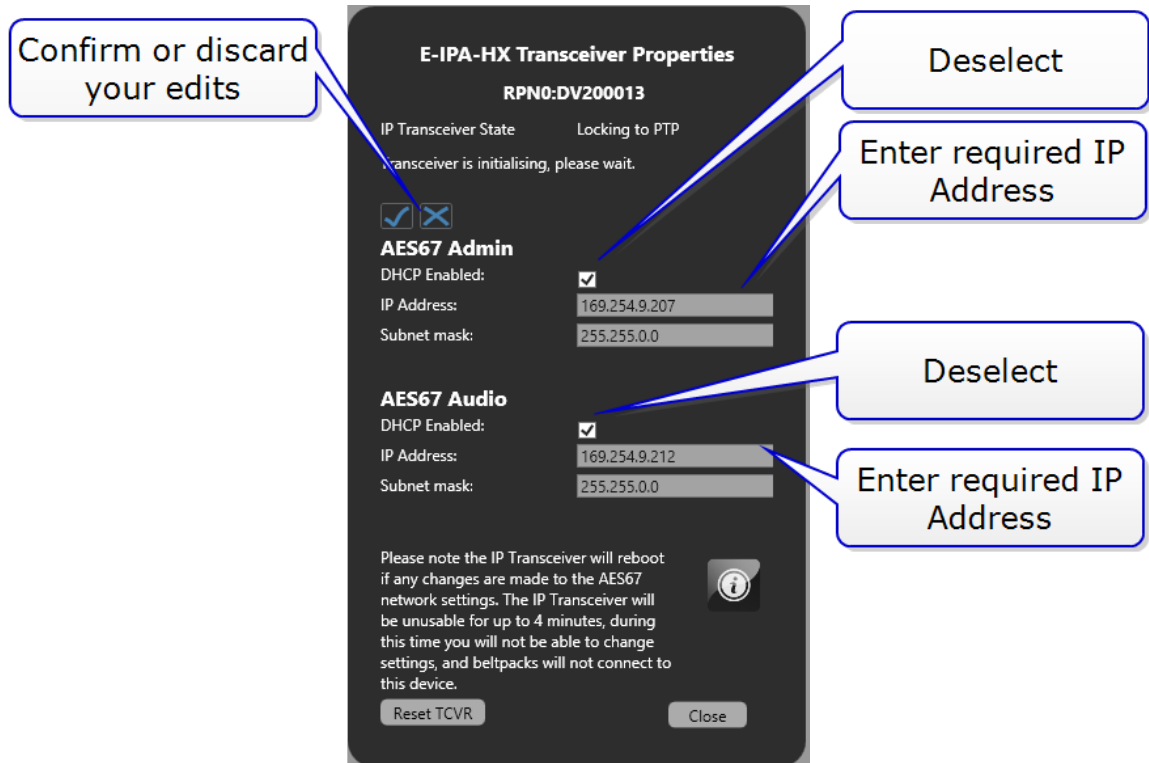

9. Click the tick or cross icon to accept or discard changes.
10. Click **Close**.
11. Click **Apply Map to Matrix**.

6.11 Powering the transceiver

The transceivers can use:

- Power over Ethernet (PoE). Connect to LAN 1 RJ45.
Note: The transceiver is a Class 3 PoE device.
- Local power. Use the supplied power supply.
- USB power from a USB battery pack. For standalone mode, this is 3 A, 5V.

6.11.1 Power redundancy

You can simultaneously power the IPT using a local power supply and PoE. In this case, the following applies:

- If the IPT is using a local power supply, adding a PoE connection causes no power interruption.
- If the IPT is using a PoE connection, adding a local power supply interrupts the power supply for 1 to 2 seconds.

- If the IPT is using both local and PoE, if you remove the local power supply connection, the IPT power supply is interrupted for 1 to 2 seconds and then continues using the PoE supply.
- If the IPT is using both local and PoE, if you remove the PoE connection, the IPT continues to operate without interruption using the local power supply.

6.12 Upgrading the FS II IP Transceiver firmware

You can upgrade the transceiver firmware by:

- Upgrading from the matrix (the file extension for the upgrade firmware is .fww)
- Using a USB connection (the file extension for the upgrade firmware is .fws)

6.13 Upgrading from the matrix

1. Right-click on the Frame in the Layout window, and then select **Firmware > Update Firmware**. The Update Firmware Wizard appears.
2. Select **Next**. The following screen appears:

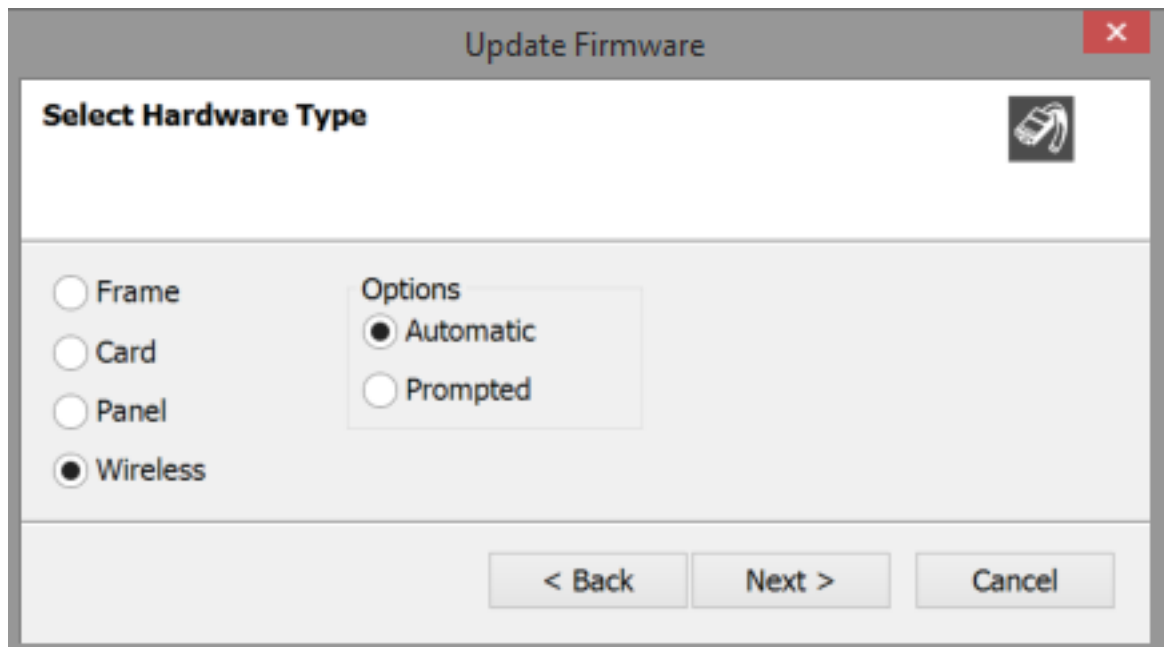

Note: For IPT Transceivers, the **Auto/Prompted** radio button is always set to Auto.

3. Select the **Wireless** radio button.
4. Select **Next**, and then browse to the upgrade file (.tar.gz) and select Open. The upgrade file is loaded to the transceiver, and the transceiver restarts.

You can track the status of the download in the EHX Event Log.

6.14 Upgrading by USB connection

Place the *.tar.gz upgrade image onto a USB stick in a folder named *firmware_upgrade* located in the root of the USB FAT32 file system.

Note: Make sure that there is only one upgrade image in the folder. If not, the incorrect image might be upgraded.

The upgrade will begin automatically when you insert the USB stick.

Note: Both status LEDs will flash light blue once per second for 5 seconds on successful detection of the upgrade file. Both status LEDs will light solid red if there is an error during the upgrade.

6.15 Port security settings

The following port security settings apply for the IP Transceiver.

Note: All ports are closed by default, and the firewall is enabled.

Port	Setting
AES67 Admin	DHCP (67, 68) mDNS (5553) HTTP (80, 8080, 443) rsync (873) IVP port is configurable
AES67 Audio	DHCP (67, 68) PTP (319, 320) mDNS (5353) IVP (6001) HTTP (8080)

6.16 Network and synchronization

- The transceiver is shipped with DHCP enabled (default). The transceiver supports static IP addressing, but if you use a static IP you will need to enter two static IP addresses.
- When the transceiver is reset to default it will revert to DHCP mode, and the AES67 Admin interface is set to DHCP.
- When budgeting for network bandwidth be aware that the transceiver will take a bandwidth of 12 Mbps.

- Be aware that in order to achieve reliable DECT sync, your AES67 network has a lower tolerance of jitter and delay than other AoIP networks.
- If the AES67 IP address on the transceiver changes, the device will reboot. This may take up to 5 mins.

6.17 General network and switching rules

The following table lists general system and switch requirements for small, medium and large configurations.

System size	Configuration	Switch requirements
Small	Up to 10 IPTs Up to three layer-2 hops between the PTP master and IPTs Clear-Com AES67 traffic only	DiffServ QoS
Medium	10 to 30 IPTs Up to three layer-2 hops between PTP master and IPTs Clear-Com AES67 traffic only	DiffServ QoS IGMP Snooping IGMP Querier
Large	More than 30 IPTs More than four layer-2 hops between PTP master and IPTs Mixed network traffic	DiffServ QoS IGMP Snooping IGMP Querier PTP Transparent and/or Boundary clocks

6.18 Beltpack support capacities for FS II IP Transceivers

FreeSpeak II for Eclipse HX supports up to a maximum 64 beltpacks per matrix.

Each FreeSpeak II IP transceiver supports 10 beltpacks within one coverage zone.

When designing the system, determine how many beltpack users will be in or passing through a given coverage zone. If it will be 10 or fewer users, then place one transceiver in the center of that area. If it is between 10 and 20 users, place two transceiver next to each other, both with a direct connection to the FS II Matrix.

If an extra beltpack user goes into a coverage zone with only one transceiver, and that user is out of range from another transceiver, it will lose connection with the system. This is because the transceiver has a maximum capacity of up to 10 beltpacks at a time. If one of the existing users in

that coverage area turns off a beltack or leaves the area, then the extra beltack will find an open slot and will be reconnected with the system.

The proprietary technology within FS II permits the beltack user to go between coverage zones created by different transceivers connected to the Matrix, and for the system to hand over the communication between beltack and Matrix from one transceiver to the next one. Thus, a larger, customizable communications area may be designed.

6.19 Coverage areas under various conditions

Just as with any other product communicating with radio waves, the effective distance between the beltack and the transceiver (the range) will differ depending on the particular environment in which it is being used. Radio waves can be attenuated by walls, floors, ceilings, trees, shrubbery, the human body (such as an audience), and numerous other objects. They can be reflected and/or stopped by metallic objects such as structural beams, safety doors, lighting equipment and truss, bodies of water, and so on.

Under ideal conditions, the maximum range between an FS II beltack and a transceiver is 500 metres. Typical distances are between approximately 50 metres (about 160 feet) and 150 metres (about 485 feet), depending on the particular environment.

As the transceiver requirements for a particular installation are being determined, keep in mind both the number of beltack users who will be working in a particular area (based on the 10 beltack capacity of each transceiver), and the layout and potential RF attenuating and reflecting items in the location. Be conservative in distance estimates to make sure that enough transceivers are included to provide the necessary coverage for the installation. Remember that additional transceivers may be added to a Matrix.

6.20 FS II Transceiver setup rules and tips

Keep the following general rules and tips in mind:

- Keep transceivers high (typically, though lower placements away from interfering objects can at times be beneficial) and line-of-sight.
- Keep them away from larger metallic objects and surfaces, and from lighting truss.
- Transceiver coverage is circular so put the transceivers in the center of the area in which coverage is required.
- When overlapping the coverage zones of transceivers to create larger continuous coverage areas, test the in-between areas with a beltack for potential areas of low RF signal; adjust the positioning of the transceivers as needed.

- Because of potential body shielding during movement, it is useful to place two transceivers in different locations within larger working areas to minimize low-level signals and potential signal dropouts.
- Going between a larger area and a corridor via a door, especially a heavy or shielded one, or where the walls are thick, place a second transceiver in the corridor near the doorway to assure continuous coverage.

6.21 Spare parts

The IP Transceiver has the following spare parts.

- SFP-MMFO-2G-SX 2GBPS MM SX FIBER SFP
- SFP-SMFO-2G-LX 2GBPS SM LX FIBER SFP
- 453G032-1 Power Supply Unit 12VDC 60W LVL 6 SWITCHING
- T13532-1 Fan Spare Assembly (2 x Fan and labelled bag or box)
- T13543-1 Input Filter Assembly (2 x Input Filter and labelled bag or box)
- T13554-1 Output Filter Assembly (1 x Output Filter and labelled bag or box)

7 Operating the FS II Transceiver

This chapter describes the FS II Transceiver that connects to an E-Que card in the matrix. For information about the FreeSpeak II IP Transceiver, see **Operating the FS II IP Transceiver (IPT) on page 49**.

The FS II transceivers form the transmission link between the FS II beltpacks and the matrix. It has internal omnidirectional (all directions/circular coverage) transceivers. Multiple units are used to support the beltpacks and to create larger, customized coverage areas. Each transceiver is connected to the E-Que card on the matrix, either directly or via a PD2203 splitter.

The unit has two methods of fixing:

- Three screw points for mounting on a flat surface.
- Two microphone stand connectors, 3/8 in and 5/8 in.

7.1 IP rating (Protection Marking)

The transceiver has an IP rating of IP53 so it can be mounted outside and will be resistant to weather conditions.

7.2 FS II transceiver connector panel



Key to transceivers	
Feature	Description
A	USB connector. Used to upgrade the firmware in the FS II-TA.
B	Matrix connector. This RJ-45/etherCON connector is used to connect the bi-directional signal from the matrix, directly or via the splitter. Up to 800 metres (2625 feet) of 4-pair 24AWG shielded Ethernet cable (CAT5/5e/6) can be used for this connection between matrix and transceiver. If 26AWG cable is used the maximum distance is 400 metres (1312 feet).
C	DC in power connector. This connector is used to locally power the transceiver with the supplied universal power supply. Use of local power is required when the transceiver is located more than 100 metres (328 feet) from the matrix or the splitter, and is recommended even when the transceiver is closer whenever it is available and convenient.
D	Data signal/Power LEDs. This amber LED indicates that a connection has been established between the matrix and the transceiver, and that it is actively creating a coverage zone within which the beltacks can operate. A flashing amber LED indicates that a data connection has been established with the matrix. A solid amber light shows that there is a DECT synchronization lock between the devices. A solid light is required for normal operation of the system.
	Power LED. This LED indicates that the transceiver is receiving power, either from its local power supply or from the connected CAT-5 cable (distances up to 100 metres, or 328 feet, from the matrix or the splitter) being powered via the FS II Matrix. This light is green for FSII 1.9 GHz devices and blue for FSII 2.4 GHz devices.
E	Mode button. The mode button is currently not in use.

7.3 Cabling the FS II transceivers

The transceivers can be cabled in two modes:

- Transceiver mode – connect directly to transceiver (up to 8 transceivers per E-Que card)
- Splitter mode – connect to transceiver via splitter (up to 2 splitters; 10 transceivers per card).

Note: *A matrix system can support up to four E-Que-HX cards (six for an Omega matrix). This makes the maximum number of transceivers per system up to 40.*

To select a transceiver connection mode, you will need to set the card type in the EHX software, in Cards and Ports, before connecting the devices.

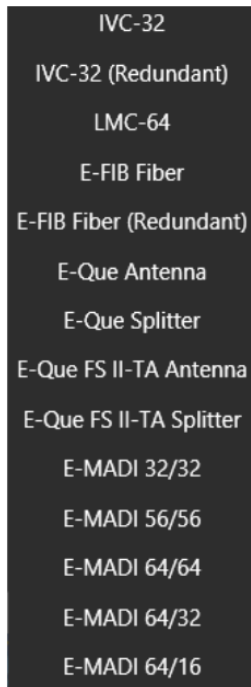

**EHX > Hardware > Cards
and Ports > Card Slots
(right click) > Set Card Type**

7.3.1 Transceiver Mode



E-Que-HX card rear connectors, antenna mode



- Up to 8 antennas can be linked directly to the E-Que card
- No splitters
- Antennas must be powered locally

c

7.3.2 Splitter mode

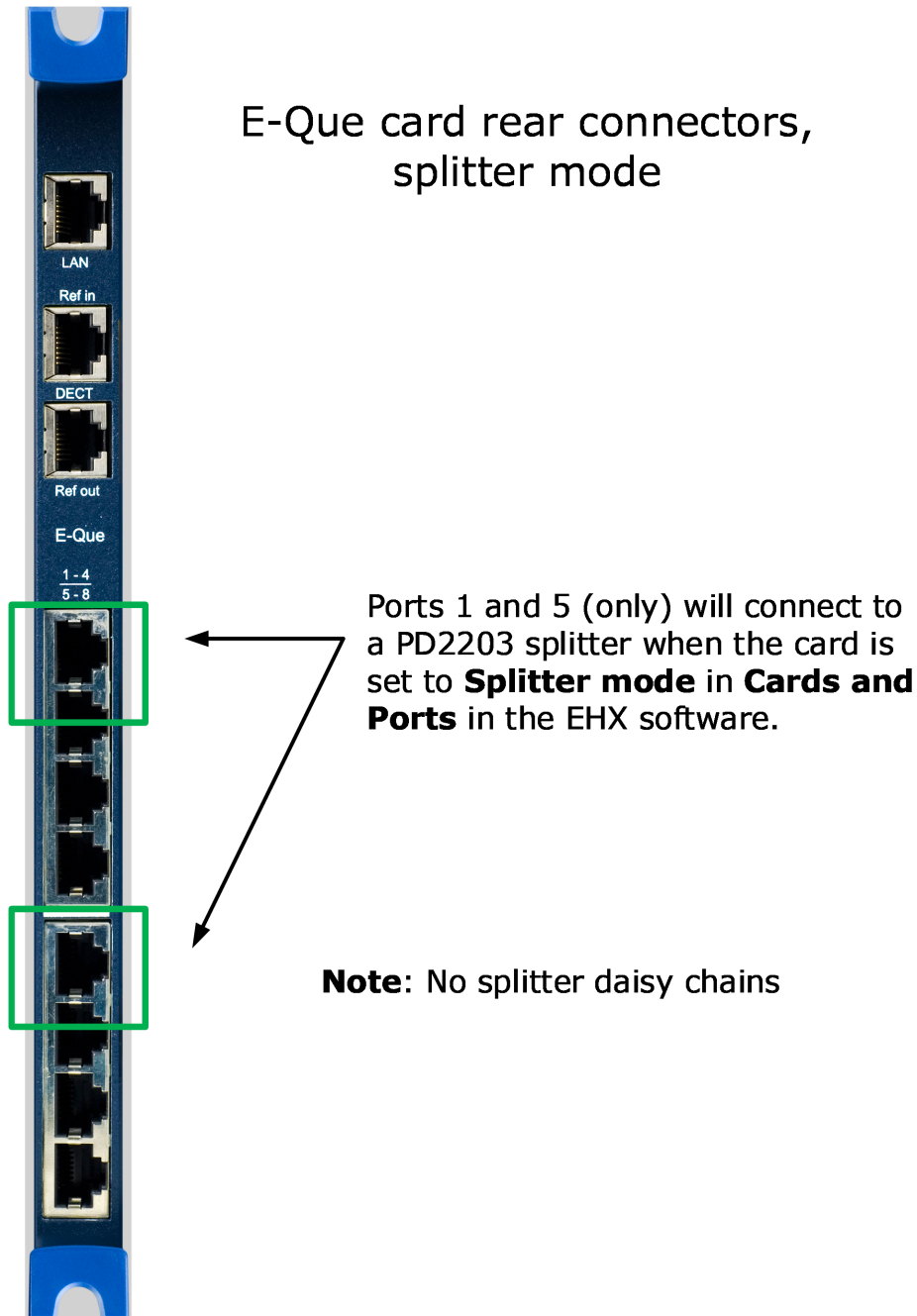

7.3.3 Connect matrix to splitter or transceivers

Once you have set the card type in EHX, run standard Ethernet cable (Cat 5e/6) from the RJ45 connectors on the back of the E-Que card to the ports labeled Matrix on the splitter or transceiver.

- Transceiver: Port labeled Base/Matrix.
- Splitter: Port labeled Matrix.

7.3.4 Connect splitters to transceiver

Run standard Ethernet cable from one of the RJ45 connectors on the splitter to the RJ45 connector labelled Base/Matrix on the transceiver.

7.3.5 Cable lengths, matrix to splitters and transceivers

Maximum Cable Lengths and Powering, FreeSpeak II for Eclipse-HX

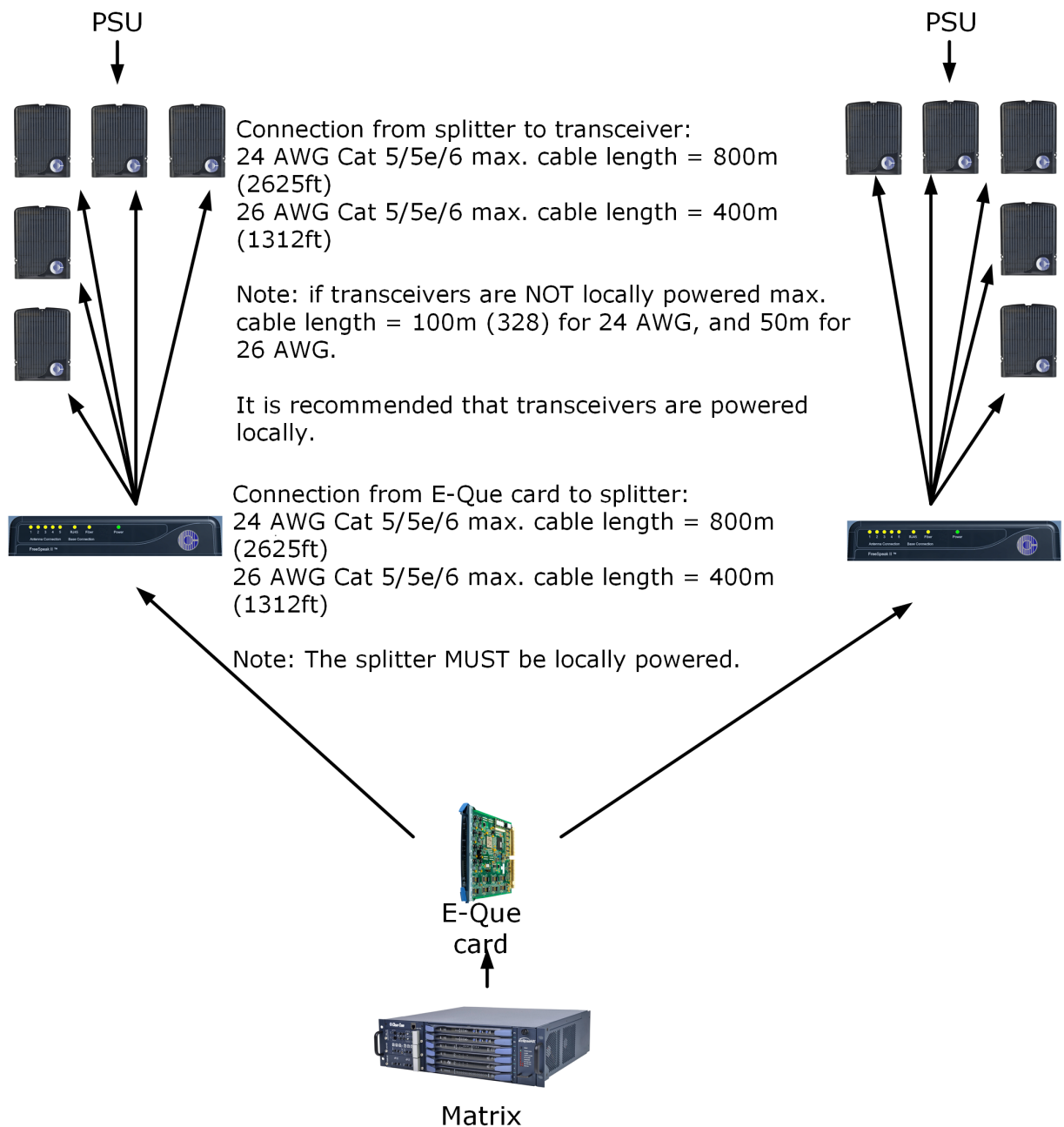

7.4 Beltpack support capacities for FS II Transceivers

FreeSpeak II for Eclipse HX (FS II used with a Matrix) will support up to a maximum 50 beltpacks per E-Que-HX card. As the Matrix can support up to 4 E-Que-HX cards, a maximum of 200 beltpacks can be used, according to conditions.

Each FSII 1.9 GHz transceiver can support five beltpacks within one coverage zone. Each FSII 2.4 GHz transceiver can support four beltpacks within one coverage zone. This reduction is due to system losses in the 2.4 GHz frequency range. With the omnidirectional transceivers, the coverage pattern is circular, with a maximum range of up to 500 metres. An average range will be 50 – 150 metres from the transceiver.

When designing the system, determine how many beltpack users will be in or passing through a given coverage zone. If it will be five or fewer users, then place one transceiver in the center of that area. If it is between 6 and 10 users, place two transceiver next to each other, both with a direct connection to the FS II Matrix or splitter. In larger systems – approaching 20 beltpacks – it is advisable to allow one transceiver for every 2 to 4 users to ensure smooth handoffs between transceivers. It is good practice to have each beltpack “seeing” two or more transceivers, so a minimum of two transceivers in any system is to be considered.

If an extra beltpack user goes into a coverage zone with only one transceiver, and that user is out of range from another transceiver, it will lose connection with the system. This is because the transceiver has a maximum capacity of up to five beltpacks at a time. If one of the existing users in that coverage area turns off a beltpack or leaves the area, then the extra beltpack will find an open slot and will be reconnected with the system.

The proprietary technology within FS II permits the beltpack user to go between coverage zones created by different transceivers connected to the Matrix, and for the system to hand over the communication between beltpack and Matrix from one transceiver to the next one. Thus, a larger, customizable communications area may be designed.

For more information on the coverage range of the FS II-TA, see 3.5 **Determining coverage areas on page 79**.

Note: *For most working systems, Clear-Com recommends a ratio of 2-4 users per transceiver due to system losses.*

7.5 Placing the transceivers and splitters

Note: *You can only use the FS II splitter with FS II transceivers that connect to an E-Que card. You cannot use the splitter with the FreeSpeak II IP Transceiver.*

The next step is to begin placing transceivers and splitters to provide the necessary coverage areas for all of the beltpacks. The first placements of transceivers and splitters will be experimental and temporary. After placing the transceivers, walk through the coverage areas to check for gaps and then re-locate the transceivers accordingly.

More information on checking coverage areas is given later in this chapter, in sections:

- **Determining coverage areas on page 79**
- **Doing a site survey to determine coverage areas on page 81**

Consider the following:

- What areas will have more than five active beltpack users in them at any time? Co-locate a second transceiver there.
- Is there a central place to locate a transceiver so that it will provide omnidirectional (all directions / circular) coverage?
- Are there balcony areas, corridors, or other rooms or areas that will require coverage with transceivers?

For systems with up to eight transceiver/transceivers, the cable runs will go directly from the transceiver ports on the rear of the E-Que card. If you need more transceiver/transceivers you will need to decide where the splitters that feed these will be located.

The E-Que card supports two splitters. Each splitter supports up to 5 transceiver/transceivers which in turn support up to 5 beltpacks.

For transceiver coverage options see **Determining coverage areas on page 79** in this chapter.

7.5.1 Wiring the transceivers and splitters

Note: *You can only use the FS II splitter with FS II transceivers that connect to an E-Que card. You cannot use the splitter with the FreeSpeak II IP Transceiver.*

To wire transceivers and splitters:

1. Make sure that the local power supplies are plugged into the transceivers and splitters.
2. Run 4-pair shielded Ethernet cable from the matrix (the E-Que card) to the transceiver or splitter, and determine that the transceiver or splitter is showing both power (green) and signal (amber) LEDs. If the amber data LED flashes, a data link is established, and if the LED is solid, DECT synchronization is established and the system is ready to use.

The E-Que card will not provide power to the transceivers or splitters.

During the initial system setup, before walking through the system with a beltpack to check for gaps in coverage, it is wise to avoid “permanently” installing the transceiver/transceivers. Hold them in place in some temporary way until their optimal position is determined.

Note: *4-pair shielded Ethernet cable (CAT-5/5e/6) with RJ-45 connectors on each end is specified for connection between the matrix and the transceiver/transceivers. Use of other cable can result in markedly shorter distances of cable runs and other possibly other performance problems.*

7.6 Determining coverage areas

After the transceivers and splitters (if present) have been initially set up proceed to test the coverage areas and re-locate transceivers and splitters, if necessary, for optimal coverage.

The following figure illustrates some FreeSpeak II coverage scenarios.

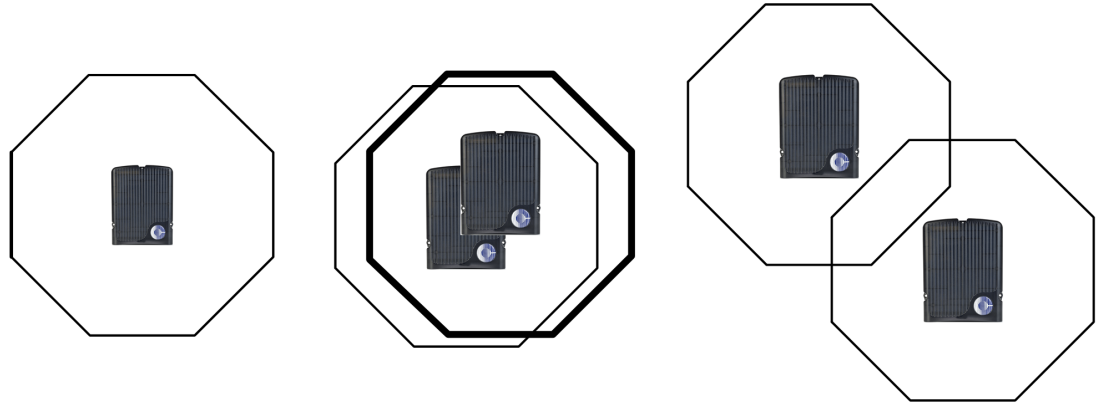

- Each antenna covers a certain range or cell size.
 - Maximum line of sight range: up to 500m (1640ft).
 - Typical range: 50 - 150m (160 - 490ft).
 - Each antenna covers 5 full duplex users (beltpacks).
- If two or more antennas are placed in the same area the cell size is the same.
 - However, cell density has increased to handle up to 10 users in the same area.
- If antennas are placed across the site then this increases radio coverage area.
 - Beltpacks can roam from one antenna to another and stay in constant communication.

Note: Cells can be completely overlapped for density (by co-locating multiple transceivers).

Cells can be overlapped at boundaries (increases radio coverage).

For most working systems Clear-Com uses a ratio of 3-4 (1.9GHz) or 2-3 (2.4GHz) users per transceiver. This is to allow seamless roaming in all scenarios.

Note: Under ideal conditions, the maximum range between an FS II beltpack and a transceiver is 500 metres. Typical distances are between approximately 50 metres (about 160 feet) and 150 metres (about 490 feet), depending on the particular environment.

7.6.1 To determine coverage areas

When the matrix, splitter(s), and transceivers have been placed and wired, turn on an FS II beltpack (assuming that it has been registered with the system) and walk the coverage area.

Alternatively, use the Site Survey mode on the beltpack (see **Doing a site survey to determine coverage areas on page 81** below). It is often best to begin with one transceiver in place, and then place additional units to enhance coverage.

Walk through all of the areas where backpack users will typically be moving, and note any areas of weak signal, dropout, or disconnection from the system. Pay special attention to the overlap areas between transceiver coverage zones, making sure sufficient signal strength is there from each of the transceivers to make a clean handoff between them for the backpack.

7.7 Coverage areas under various conditions

Just as with any other product communicating with radio waves, the effective distance between the backpack and the transceiver (the range) will differ depending on the particular environment in which it is being used. Radio waves can be attenuated by walls, floors, ceilings, trees, shrubbery, the human body (such as an audience), and numerous other objects. They can be reflected and/or stopped by metallic objects such as structural beams, safety doors, lighting equipment and truss, bodies of water, and so on.

Under ideal conditions, the maximum range between an FS II backpack and a transceiver is 500 metres. Typical distances are between approximately 50 metres (about 160 feet) and 150 metres (about 485 feet), depending on the particular environment.

As the transceiver requirements for a particular installation are being determined, keep in mind both the number of backpack users who will be working in a particular area (based on the 10 backpack capacity of each transceiver), and the layout and potential RF attenuating and reflecting items in the location. Be conservative in distance estimates to make sure that enough transceivers are included to provide the necessary coverage for the installation. Remember that additional transceivers may be added to a Matrix.

7.8 FS II Transceiver setup rules and tips

Keep the following general rules and tips in mind:

- Keep transceivers high (typically, though lower placements away from interfering objects can at times be beneficial) and line-of-sight.
- Keep them away from larger metallic objects and surfaces, and from lighting truss.
- Transceiver coverage is circular so put the transceivers in the center of the area in which coverage is required.
- When overlapping the coverage zones of transceivers to create larger continuous coverage areas, test the in-between areas with a backpack for potential areas of low RF signal; adjust the positioning of the transceivers as needed.
- Because of potential body shielding during movement, it is useful to place two transceivers in different locations within larger working areas to minimize low-level signals and potential signal dropouts.

- Going between a larger area and a corridor via a door, especially a heavy or shielded one, or where the walls are thick, place a second transceiver in the corridor near the doorway to assure continuous coverage.

7.9 Doing a site survey to determine coverage areas

You might want to test coverage areas more extensively before setting up a complete system. Testing a system in the setting in which it will be located helps to meet operational needs. Factors in the local setting may affect the areas a system can cover, so it is important to plan a site setup accordingly.

Doing a complete site survey, as described below, helps to set up an optimal system. You can do a site survey using a beltpack that is connected to the system or one that is not connected to the system.

7.9.1 Doing a site survey with a beltpack

1. Link one beltpack to the matrix.
2. Place one connected transceiver in the center of the coverage area.
3. Put the beltpack into Site Survey mode using the beltpack menu. See **Operating the wireless beltpack on page 21**. The following figures show the information that the Site Survey mode displays for connected and unconnected beltpacks.

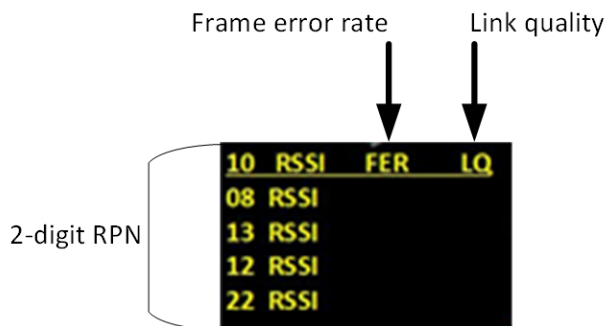

Parameter	Meaning
Received Signal Strength Indication (RSSI)	A measure of the signal strength in a wireless environment. The higher the value, the stronger the signal.
Frame Error Rate (FER)	A measure of the signal connection quality. The lower the FER, the better the signal connection.
Link Quality (LQ)	A combined quality metric ranging from 1 (poor) to 5 (high).

4. Walk around the transceiver with the beltpack, monitoring the beltpack signal strength and quality metrics.
 - The signal strength is shown in the Received Signal Strength Indication (RSSI) field.
 - The signal strength number will fluctuate, ranging between 0 - 59 as you walk through the coverage area, and may even fluctuate as you stand still. As a rule-of-thumb the best system performance will be obtained when the signal strength remains at 30 or above. If the signal strength falls below 30 the beltpack may start losing audio. This is the limit of the coverage zone.
 - A high Received Signal strength indication and a high Error rate may indicate that there is another RF system causing interference.
 - A beltpack can transmit to a transceiver at a range of approximately 500m in good conditions.
5. Draw a map of the coverage zone for the transceiver. The coverage zone is the area where the signal strength, as a rule-of-thumb, is 30 or above and the Line Quality is 3-5.
6. Repeat this process for as many transceivers as necessary to cover the required area. Overlap coverage zones so that there is no area where the signal strength is below 30, and no area where the error rate is above a few percent.
7. Adjust the transceiver placement to get the best coverage.

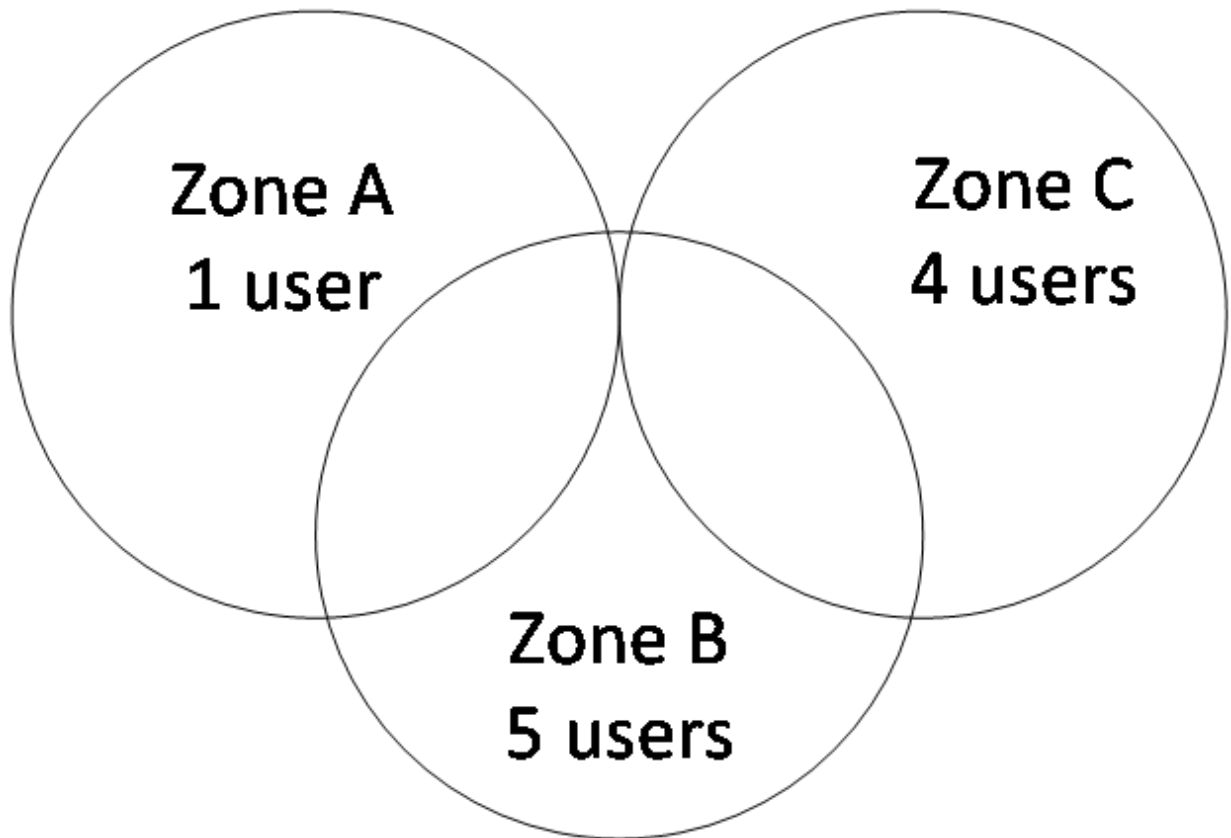

In some environments you might observe that despite having a high signal strength, the beltpack consistently reports a high error rate.

This could be due to two things:

- In-band interference from an RF source broadcasting in the DECT area of the spectrum. This can be verified using a DECT band monitor or by using a Spectrum Analyzer.
- Long Delay Spread Multipath, where the signal is bounced off a number of reflective surfaces, such as metal ceilings, gantries, walkways or other large structures. This problem is greatest where the reflective surface is large and exists at a range of distances from the transceiver. To reduce the problem, consider siting the transceiver where it cannot “see” the reflective surface or installing a reflector close to the transceiver between it and the reflective surface.

7.9.2 Testing transceiver handoff

After testing the coverage areas for individual transceivers, test the handoff between the transceivers. When you walk through a coverage area with the beltpack, the beltpack searches to find the transceiver with the best signal strength, and switches transmission to that transceiver. Therefore the beltpack continually hands off transmission among transceivers as you move through the coverage area. You can determine which transceiver the beltpack is connected to using the EHX configuration.

To test transceiver handoff, connect any additional transceivers in the installation and walk through the coverage areas to ensure that the coverage is continuous and complete, without audio breakups. Reposition transceivers if necessary.

7.9.3 Assigning beltacks to coverage areas

Transceivers that operate in the 1.9 GHz band will handle up to 5 transceivers at any one time. Transceivers that operate in the 2.4 GHz band will handle up to 4 transceivers.

Although they can achieve this in good conditions, this may not always be possible for a number of reasons. First, interference or propagation problems may mean that not all transceiver slots are available all the time. Second, a beltack constantly searches for the best transceiver signal, and may frequently switch transceivers. To make this transmission seamless, a beltack maintains the connection to its current transceiver until it is confident that the new transceiver is functioning well. Therefore, for a short period of time during this transition, a single beltack can occupy slots on more than one transceiver.

This means that for zones likely to need coverage for five or more beltacks simultaneously it is recommended that a second transceiver is installed. Similarly, for good coverage for nine or more beltacks simultaneously, a third transceiver may be required (remember that the 2.4 band will support one less beltack per transceiver).

7.9.4 Conditions affecting coverage areas

The environment in which a system is located affects the coverage area for any particular beltack/transceiver combination. The presence of walls, floors, ceilings, trees, shrubbery, people, and numerous other items may affect the coverage zone. Metallic objects, safety doors, lighting equipment, and bodies of water may possibly block transmission. These factors must be taken into consideration when planning the installation.

7.9.5 Surveying a site in standalone (rigging) mode

You might need to scope a site (check the range and performance of a transceiver) without connecting to a matrix. To do this, one or two beltacks and transceiver can be put into standalone or rigging mode. If you have two beltacks, they automatically have duplex audio.

To put a beltack and transceiver into standalone mode:

1. Make sure you have to hand:
 - A beltack
 - A transceiver
 - A power connector for the transceiver
 - Access to a power socket.

2. Connect the power to the transceiver and at the same time press the black mode button on the base of the transceiver.
This puts the transceiver in standalone mode, and opens it for pairing to a beltpack.
3. From the beltpack, press the menu key (3 second press) and navigate to System Connect using the right hand rotary controller on the beltpack.
4. Press button D to see local systems available for connection.

In menu mode the D key on the beltpack operates as SELECT and the C key exits the menu level and cancels the selection.

5. Scroll through available systems using the right hand rotary controller.
6. When you have found the transceiver to pair to (it will be showing a 'P' to indicate that it is ready to be paired to the beltpack) press button D to select the transceiver and connect the beltpack to it.
7. When the beltpack is successfully connected to the transceiver, navigate to Site Survey in the beltpack menu and monitor the range and performance of the transceiver. For more information on Site Survey functionality see **Doing a site survey with a beltpack on page 81**.

To establish **Standalone** mode on an antenna:

1. Connect power cable and press **mode** button **at the same time**.

2. Amber signal light will flash when device is in **Standalone** mode.



3. When amber LED is flashing, a beltpack can be connected/ paired to the antenna in order to be able to see details of the antenna's radio frequency (RF) coverage.

7.10 Registering beltpacks

Before you can use a beltpack, you must first register it with the FreeSpeak II system. The beltpacks can be registered to an Eclipse matrix (Omega, Median or Delta) using Eclipse HX

software (EHX).

You can register the beltacks using a USB cable or over the air (OTA).

To register FreeSpeak beltacks with the system see the Eclipse HX Software Configuration User Guide, 5.59 FreeSpeak II Beltacks.

7.11 Upgrading FS II Transceiver firmware

You can upgrade the transceiver firmware by:

- Using a USB connection
- Using a wireless connection.

7.12 Upgrading by USB connection

1. Connect the transceiver to a USB port on the computer running the EHX software.
2. Select **Tools > Apply Wireless Firmware Via USB**.
3. Browse to the location of the upgrade file, and then select **Update Firmware**.

The upgrade file is downloaded to the transceiver.

Note: *You can connect more than one transceiver to the computer if you have multiple USB ports. The units will be upgraded sequentially.*

7.13 Upgrading by wireless connection

1. Right-click on the Frame in the Layout window, and then select **Firmware > Update Firmware**. The Update Firmware Wizard appears.
2. Select **Next**. The following screen appears:

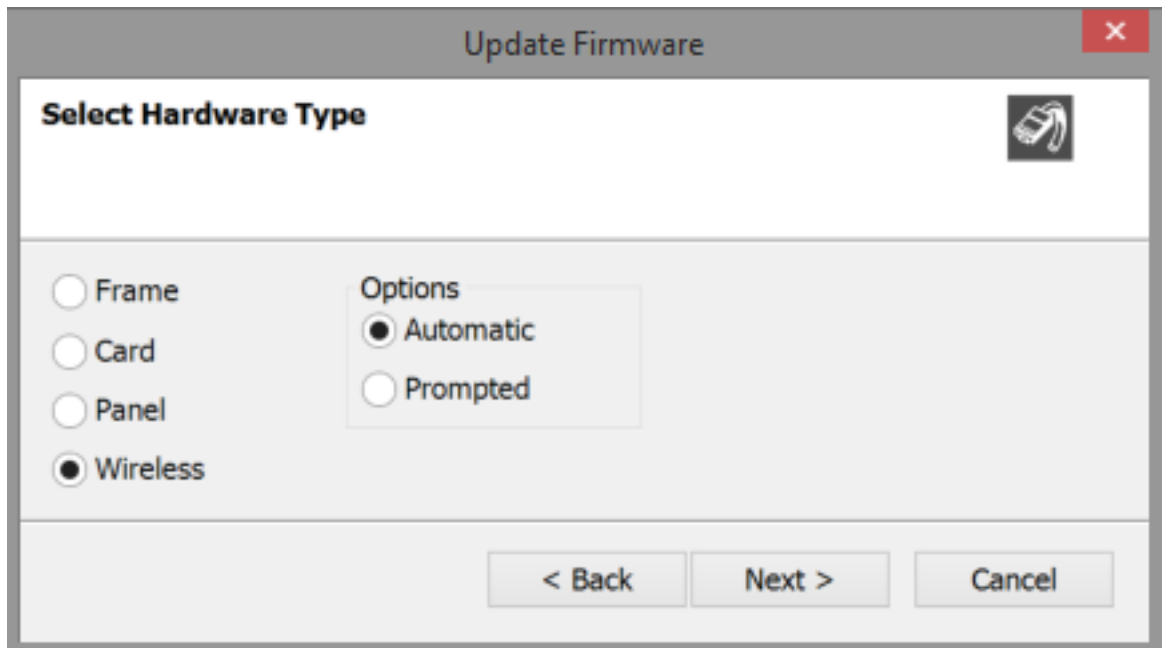

3. Select the **Wireless** radio button.
4. Select **Next**, and then browse to the upgrade file (.fww) and select Open. The upgrade file is loaded to the transceiver, and the transceiver restarts.

You can track the status of the download in the EHX Event Log.

8 Using the FreeSpeak II Base splitter (FSII-SPL)

The FreeSpeak II Base transceiver splitter is a device that connects up to five transceivers to a FreeSpeak Base (both FreeSpeak I and FreeSpeak II, 1.9 and 2.4 systems) or an Eclipse matrix. Using the splitter, audio can be routed from the Base to transceivers either via Cat5/6 Ethernet cable (RJ45) or a Fiber connection.

8.1 Configuration using a splitter with Cat 5/6 RJ45 connection

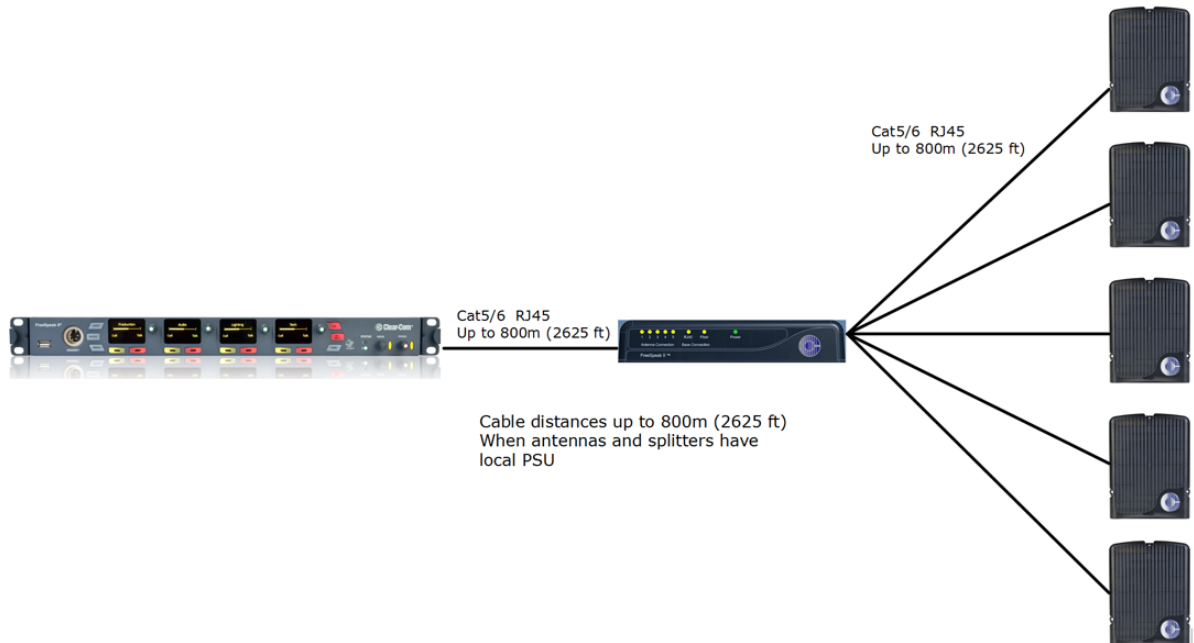

8.2 Configuration using a splitter with fiber connection

Typical FSII-Base/FSII-splitter configurations using Clear-Com equipment

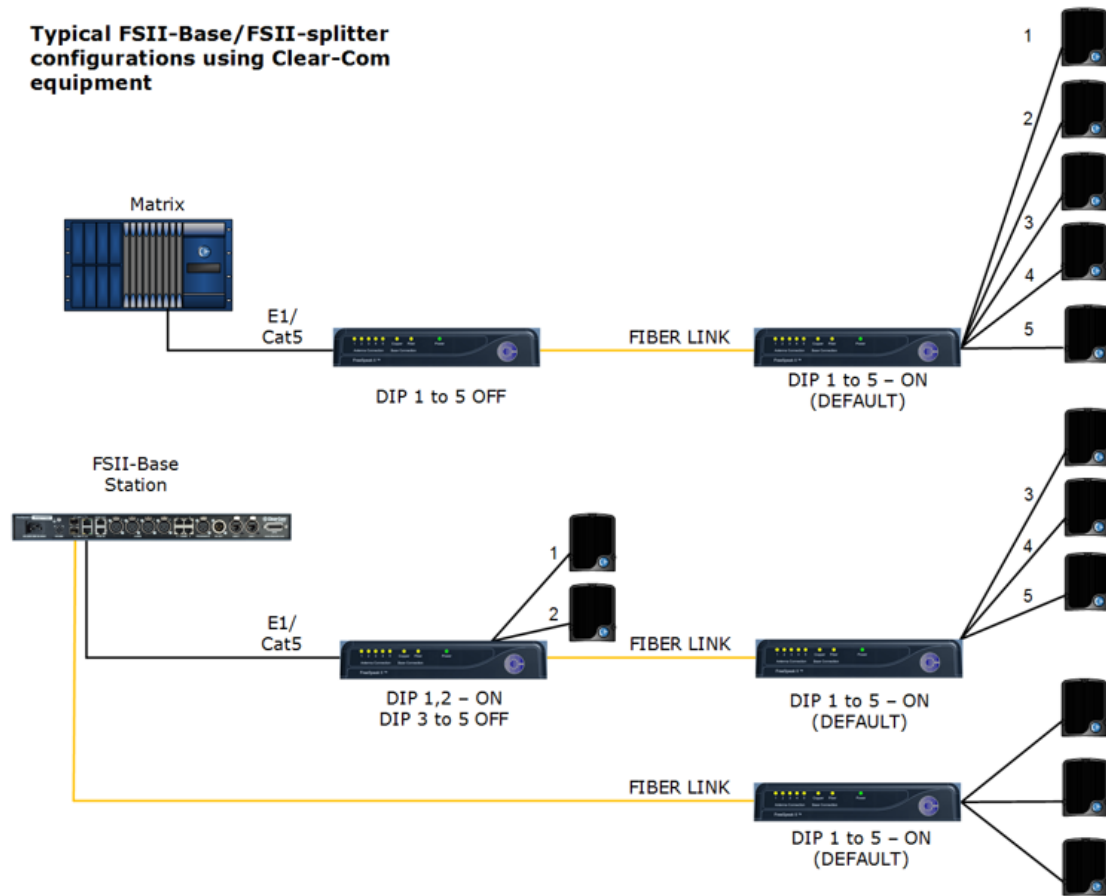

Typical system configuration using third party equipment

Note: In this configuration, there is no DECT Synchronization from the Base Station or matrix (DIP 6 - OFF). Only local DECT synchronization is possible.

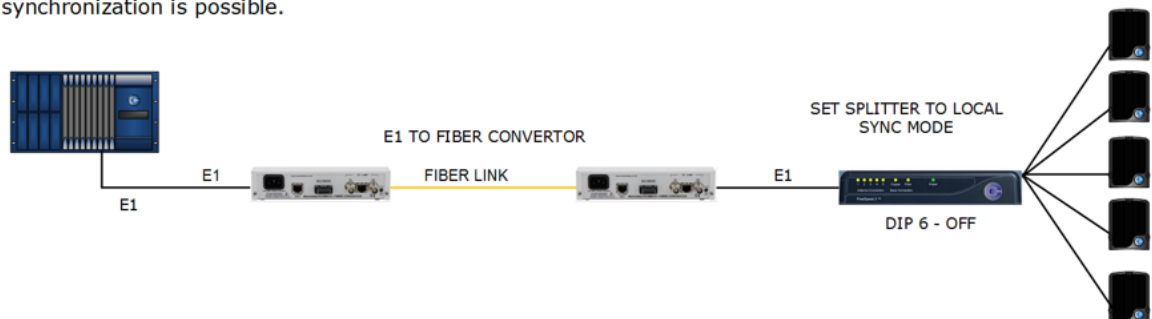

The transceiver connections are switched between RJ45 and Fiber routing using dip switches set inside the splitter.

3

DIP switch settings (default in **BOLD**)

1 to 5	Antenna ports 1 to 5 ON – Active OFF - Convert to Fiber
6	ON – Base Sync OFF – Local Sync
7	If 6 is switched to OFF ON – FreeSpeak II OFF – FreeSpeak I
8	ON – Update OFF – Normal operation

To access the DIP switches, remove the covering panel on the base of the splitter (two screws).

Note: When you change a DIP switch setting, you must re-power the unit for the change to have any effect.

Note: When using Fiber, you must install Fiber modules. See link below.

Note: When using the splitter with third party routing devices, transceiver synchronisation data is not passed. In this case, you need to set the splitter to 'local synch' mode. This is done by setting the splitter dip-switch no. 6 to OFF.

For more information, see:

- [Install Fiber modules \(parts # HLI-SMFO, HLI-MMFO\) on page 92](#)
- [Printable Splitter Quick Start Guide.pdf](#)

8.3 Splitter (FSII-SPL) rear connectors

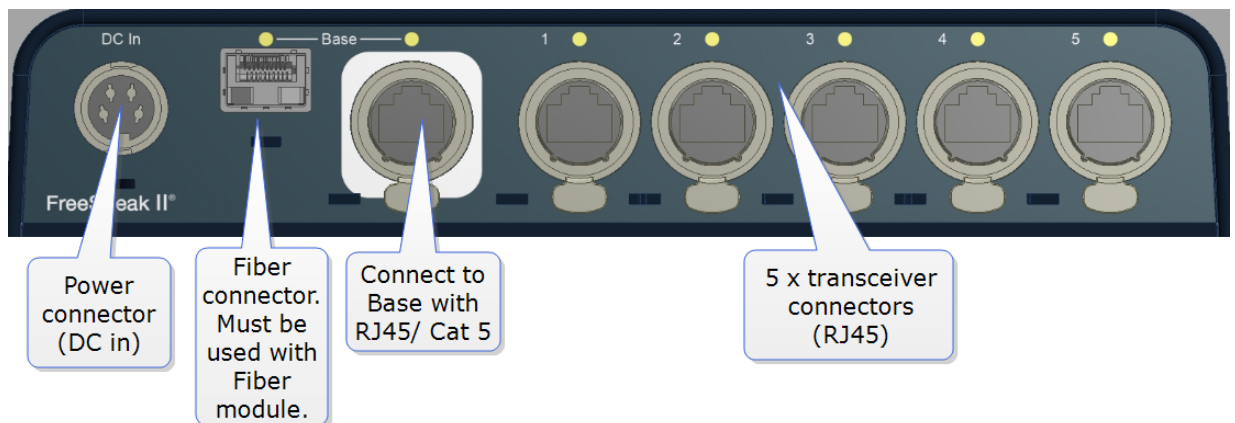

See also:

[Splitter \(FSII-SPL\) front panel on page 91](#)

[Using the FreeSpeak II Base splitter \(FSII-SPL\) on page 88](#)

8.4 Splitter (FSII-SPL) front panel

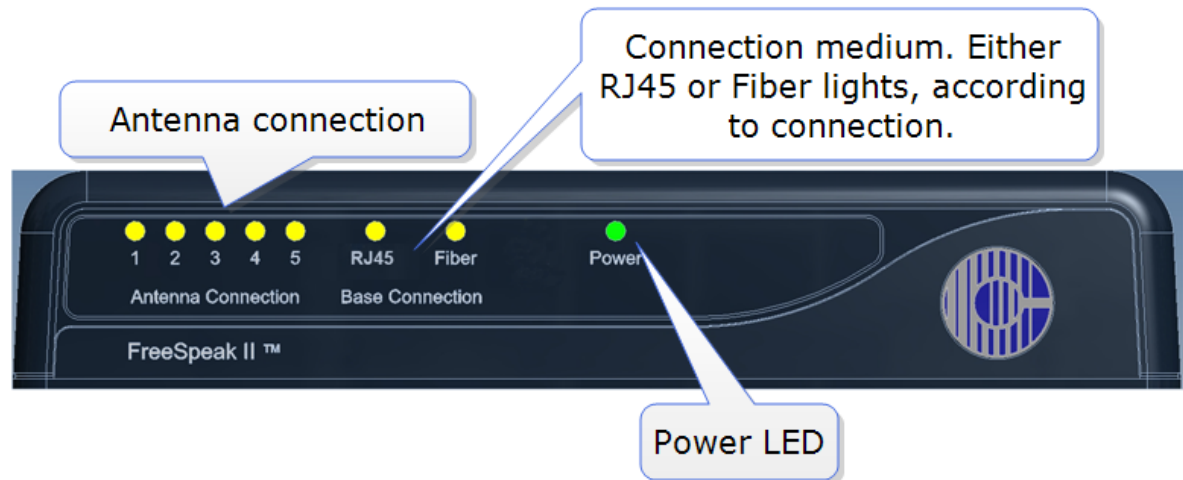

See also:

[Splitter \(FSII-SPL\) rear connectors on page 90](#)

[Using the FreeSpeak II Base splitter \(FSII-SPL\) on page 88](#)

8.5 Using a transceiver with a fiber connection

You may wish to connect a FreeSpeak II Base to a splitter (FSII-SPL) using Fiber. In this case, you need to install Fiber modules to the Base and the splitter.

- Modules are available for single mode Fiber cable (HLI-SMFO) and multi-mode Fiber cable (HLI-MMFO)
- Modules are supplied as a pair, one for the Base Station and one for the splitter.
- Modules can be hot patched, no need to power off devices.

8.5.1 Install Fiber modules (parts # HLI-SMFO, HLI-MMFO)

Install Base Station Fiber module.



Slide module into Fiber connector port.
(Remove dust cap)

Install splitter Fiber module.

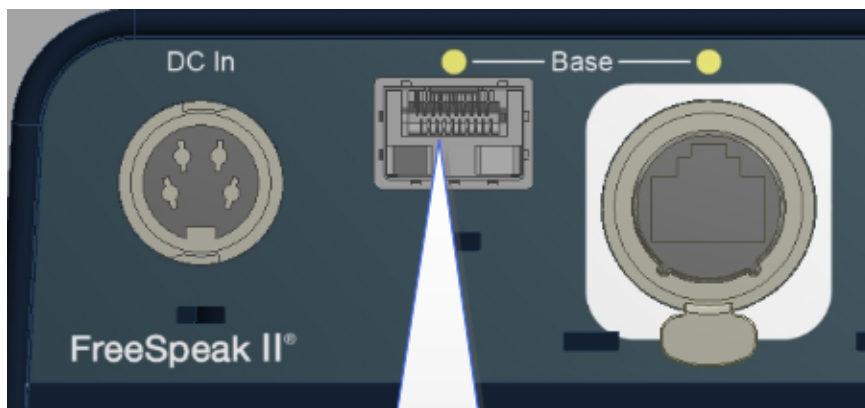

Insert Fiber module

Once the modules are installed, the Base Station and the splitter can be cabled with the correct Fiber cable (single mode or multi-mode depending on existing cabling). You will see the **Base Connection** indicator on the front of the splitter change from **RJ45** to **Fiber**.

You must also set the transceiver port to Fiber in the Core Configuration Manager. Navigate to **Device>Station>Transceiver ports**.

The screenshot displays the 'Station' configuration page in the Clear-Com web interface. The top navigation bar includes 'Overview', 'Device', 'Roles', and 'Assignments'. The left sidebar shows 'General', 'Station', 'Network', and 'Ports' tabs. The main content area is titled 'Station' and contains the following sections:

- Keypad:** Includes buttons for 'CH 1', 'Channel 2', 'Channel 3', and 'REPLY'. Below these are settings for 'Key Assignment: CH 1', 'Key Behavior: Talk & Listen', and 'Talk Latch: Latching'.
- Groups:** Shows 'Group Membership: Unassigned'.
- Headset:** Includes settings for 'Sidetone Gain: -12 dB', 'Headset Limit: 0 dB', 'Sidetone Control: Tracking', and 'Headset Mic Type: Automatic'.
- Transceiver Ports:** Shows 'Ant 1: RJ45' and 'Ant 2: RJ45'. A callout box points to these options with the text 'Click here to select **RJ45** or **Fiber**'.

A callout box at the top right points to the 'Station' tab in the sidebar with the text 'Navigate to **Device**>**Station**'.

8.6 Splitter Software Version (FSII-SPL)

Splitter software is not usually user upgradable, but if necessary you can find out the splitter software version (usually for system diagnostic purposes) by connecting to the splitter with a PC and using a serial console emulator such as Tera Term.

8.6.1 How to find out splitter software version

1. Remove the covering panel (two screws) on the base of the splitter to access a USB (micro) port next to the dip switch settings.
2. Connect the splitter to a PC using a USB A to micro B cable.
3. Allow windows to install a USB com port driver (this should be automatic).

- Using a serial console emulator (such as Tera Term), input serial console settings.

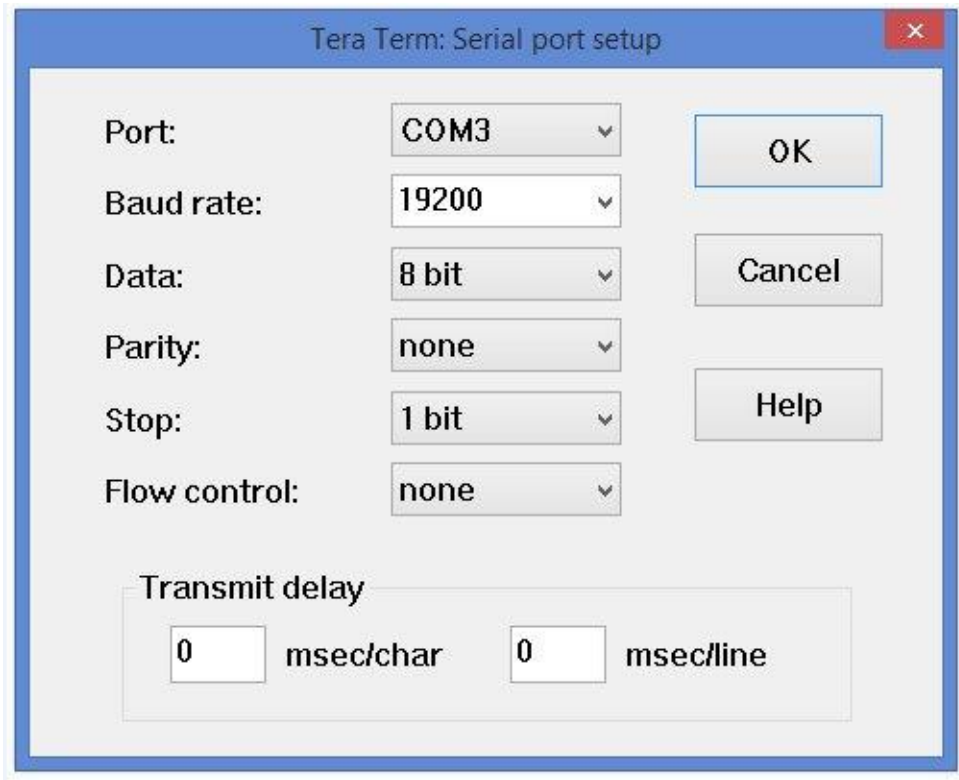

- Open the serial console. Press the space bar and the splitter will output its software version as shown.

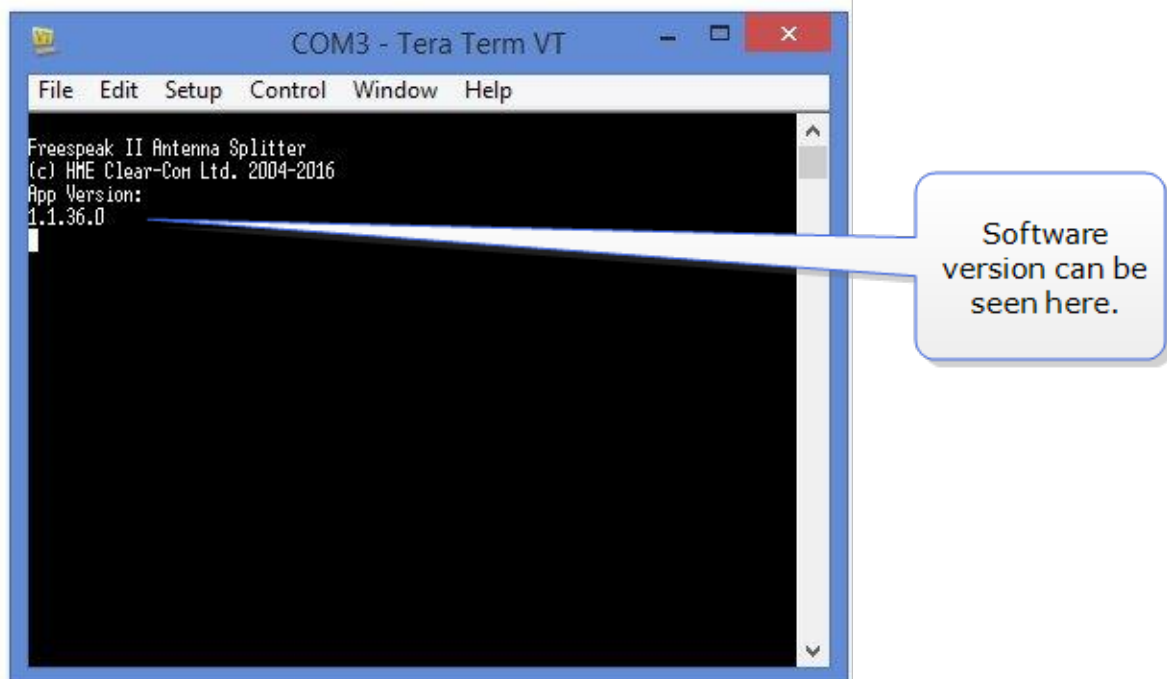

9 Specifications

9.1 FreeSpeak II beltpack

Specification	Value
Beltpack Frequency Response	100 Hz to 7.1 kHz
Beltpack Assignment-Select Buttons	2, used to edit beltpack menu options
Number of simultaneous Full-Duplex Audio Paths	Up to 7 including Reply Key and two PTT keys. Only four with individual level control.
Level/Talk Controls	2 top-mounted rotary encoders
Headset Connector	XLR-4M, Clear-Com standard
Headphone Impedance	≥32 ohm
Microphone Type	Dynamic or electret, selectable in beltpack menu
Input Level	70 to -40 dBu
Electret headphone voltage	2.3V
Microphone and Headset Limiters	Selectable in beltpack menu
Powering	Li-Ion Battery, 3 AA alkaline cells
Latency for E1	
Latency for AES67	
Battery Charging	In unit, via 5-way AC60 charger
Battery Life	Approximately 18 hours
Range from Single FSII-TCVR-19 Transceiver	500 m from transceiver in line-of-sight conditions; 50 m indoors; use multiple transceivers for larger, custom coverage areas
Approx. dimensions	38 x 130 x 100 mm (dwh) (1.5 x 5 x 3.75 inches)
Weight (with batteries)	Approx. 400g (9 oz)

9.2 FreeSpeak IP Transceiver

Specification	Value
Belpacks supported per transceiver	10 in one cellular zone
Transceiver transmission range	Up to 500 m (1475 ft.), line of sight
Local powering	12VDC power supply or 5V (USB) or 48V PoE
SFP module	1GB (1000Base), <250mA maximum current draw
Connection to matrix	RJ45
Mounting	Four fixing holes
Dimensions	60 x 180 x 220 mm (dwh)(2.4 x 7.0 x 8.7 inches)
Weight	Approx. 460g (16.1 oz)

9.3 FreeSpeak II Transceiver

Specification	Value
Belpacks Supported Per Transceiver FS II 1.9 GHz devices	Five in one cellular zone
Belpacks Supported Per Transceiver FS II 2.4 GHz devices	Four in one cellular zone
Transceiver Transmission Range	Up to 500 m (1475 ft.), line of sight
Maximum Distance, Matrix to Transceiver Via Matrix Port	800 m (2625 ft.) using shielded 24 AWG cable 400 m (1312 ft) using shielded 26 AWG cable
Local Powering	24VDC power supply
Connection to matrix	RJ-45
Mounting	Three fixing holes
Dimensions	50 x 140 x 175 mm (dwh) (2.0 x 5.5 x 6.9 inches)
Weight	Approx. 460g (16.1 oz)

9.4 FreeSpeak II Transceiver Splitter

Specification	Value
Number of Transceivers Supported	10
Number of Splitters Per Card	Two
Connection Between Matrix and Splitter	4-pair shielded CAT5 cable with RJ-45
Connection Between Splitter and Transceiver	4-pair shielded CAT5 cable with RJ-45
Powering of Splitter	Locally powered using external power supply

9.5 Transmission method

Specification	Value
Method of RF Operation	DECT and ISM standards, using two DECT bands per belt-pack
Modulation	GFSK
Frequencies of Operation	FSII 1.9 GHz 1880–1900 MHz (Europe) 1920 – 1930 MHz (North America) FSII 2.4 GHz 2400–2480 MHz (Europe and North America)
Maximum RF Output	250 mW burst, average level 2 - 4 mW (Europe) 100 mW burst, average level 2 - 4 mW (US)
Theory of Operation	Dynamic allocation of frequencies and handoff of belt-packs among the transceivers up to their individual limit of up to 10 connected belt-packs at a time; each belt-pack is assigned a virtual port within the matrix.

9.6 Notice about specifications

While Clear-Com makes every attempt to maintain the accuracy of the information contained in its product manuals, that information is subject to change without notice. Performance specifications included in this manual are design-center specifications and are included for customer guidance and to facilitate system installation. Actual operating performance may vary.

10 Regulatory compliance

Applicant Name: Clear-Com LLC

Applicant Address: 1301 Marina Village Pkwy, Suite 105, Alameda CA 94501, United States

Manufacturer Name: Clear-Com LLC

Manufacturer Address: 1301 Marina Village Pkwy, Suite 105, Alameda CA 94501, United States

Country of Origin: USA

Brand: Clear-Com

Caution: All products are compliant with regulatory requirements detailed in this document when the user follows all installation instructions and operating conditions per Clear-Com specifications

Caution: Use of accessories and peripherals other than those recommended by Clear-Com may void the product's compliance as well as the user's authority to operate the equipment.

10.1 FCC Notice

This device complies with Part 15 of the FCC rules. Operation is subject to the following two conditions: (1) This device may not cause harmful interference, and (2) This device must accept any interference received, including interference that may cause undesired operation.

NOTE: This equipment has been tested and found to comply with the limits for a Class A digital device, pursuant to Part 15 of the FCC rules. These limits are designed to provide reasonable protection against harmful interference when the equipment is operated in a commercial environment. This equipment generates, uses and can radiate radio frequency energy and, if not installed and used in accordance with the instruction manual, may cause harmful interference to radio communication. Operation of this equipment in a residential area is likely to cause harmful interference, in which case the user will be required to correct the interference at his own expense.

Changes or modifications not expressly approved by Clear-Com, LLC, an HM Electronics, Inc. company could void the user's authority to operate this equipment.

10.2 FCC/IC/EC RF Exposure Warning

- This product complies with FCC/IC/EC radiation exposure limits set forth for an uncontrolled environment.

- This product may not be co-located or operated in conjunction with any other transceiver or transmitter.

- The beltpack has been tested to comply with FCC/IC/EC RF Exposure requirements in body-worn position. Use of third party clips or holsters with the beltpack may not ensure compliance with FCC/IC/EC RF exposure requirements and should be avoided.

- To comply with FCC/IC/EC RF exposure requirements, the Antenna/Transceiver unit must be installed and operated at least 20 cm (8 inches) from any person.

10.3 Industry Canada Compliance Statement

This Class[A] digital device complies with Canadian ICES-003.

Avis de conformité à la réglementation d'Industrie Canada

Cet appareil est conforme aux CNR d'Industrie Canada applicables aux appareils radio exempts de licence. L'exploitation est soumise aux deux conditions suivantes:

(1) cet appareil ne doit pas provoquer d'interférence, et

(2) cet appareil doit accepter toute interférence radioélectrique subie, môme si l'interférence est susceptible d'en compromettre le fonctionnement.

Cet émetteur exempt de licence est équipé d'une antenne intégrée. Cet émetteur exempt de licence n'est pas autorisé à fonctionner avec une autre antenne.

Cet appareil numérique de la class[*] est conforme à la norme NMB-003 du Canada.

10.4 Korean Notice

A급 기기 (업무용 방송통신기자재)

이 기기는 업무용(A급)으로 전자파적합기기로서 판매자 또는 사용자는 이 점을 주의하시기 바라며, 가정외의 지역에서 사용하는 것을 목적으로 합니다.

10.5 KCC 2.4Ghz warning

해당 무선설비는 전파혼신 가능성이 있으므로 인명안전과 관련된 서비스는 할 수 없음

10.6 European Union (CE mark)



The CE marking indicates compliance with the following directives and standards, whenever applicable to the product in question.

Directives:

- Radio Equipment Directive 2014/53/EU

- Electromagnetic Compatibility Directive 2014/30/EU
- Low Voltage Directive 2014/35/EU
- RoHS Directive 2011/65/EU

Standards:

- EN55022/EN55032
- EN55024
- IEC/EN60950-1
- EN300328
- EN301406
- EN301489
- EN50581

Warning:

This is a Class A product. In a domestic environment this product may cause radio interference in which case the user may be required to take adequate measures.

10.7 Taiwan Statements

Taiwan NCC statement:

經型式認證合格之低功率射頻電機，非經許可，公司、商號或使用者均不得擅自變更頻率、加大功率或變更原設計之特性及功能。

低功率射頻電機之使用不得影響飛航安全及干擾合法通信；經發現有干擾現象時，應立即停用，並改善至無干擾時方得繼續使用。前項合法通信，指依電信法規定作業之無線電通信。低功率射頻電機須忍受合法通信或工業、科學及醫療用電波輻射性電機設備之干擾



Taiwan BSMI statement:

R45131

RoHS



警告使用者：

此為甲類資訊技術設備，於居住環境中使用時，可能會造成射頻擾動，在此種情況下，使用者會被要求採取某些適當的對策。

10.8 Customs Union EAEU



Russia

Regulatory Models for FSII System Products covered in this User Guide Manual

Regulatory model numbers:

Belpack 2.4Ghz: BP2G4A

Belpack 1.9Ghz: BP1G9

Transceiver 2.4Ghz: XCVR2G4A (Modular)

Transceiver 2.4Ghz: MER2G4TCVR (end-device)

Transceiver 1.9Ghz: XCVR1G9 (end-device)

Battery Charger: AC60

Battery Pack: BAT60

10.9 Waste Electrical and Electronic Equipment (WEEE)

The European Union (EU) WEEE Directive (2012/19/EU) places an obligation on producers (manufacturers, distributors and/or retailers) to take-back electronic products at the end of their useful life. The WEEE Directive covers most Clear-Com products being sold into the EU as of August 13, 2005. Manufacturers, distributors and retailers are obliged to finance the costs of recovery from municipal collection points, reuse, and recycling of specified percentages per the WEEE requirements.

Instructions for Disposal of WEEE by Users in the European Union

The symbol shown below is on the product or on its packaging which indicates that this product was put on the market after August 13, 2005 and must not be disposed of with other waste.

Instead, it is the user's responsibility to dispose of the user's waste equipment by handing it over to

a designated collection point for the recycling of WEEE. The separate collection and recycling of waste equipment at the time of disposal will help to conserve natural resources and ensure that it is recycled in a manner that protects human health and the environment. For more information about where you can drop off your waste equipment for recycling, please contact your local authority, your household waste disposal service or the seller from whom you purchased the product.

