

DKP-4016/4016W Keypanel Technical Manual

*up to and including version 1.2.0
includes support for
Control Package
Audio Package*



DKP-4016W



DKP-4016

PROPRIETARY NOTICE

The product information and design disclosed herein were originated by and are the property of Bosch Security Systems, Inc. Bosch reserves all patent, proprietary design, manufacturing, reproduction, use and sales rights thereto, and to any article disclosed therein, except to the extent rights are expressly granted to others.

COPYRIGHT NOTICE

Copyright 2016 by Bosch Security Systems, Inc. All rights reserved. Reproduction, in whole or in part, without prior written permission from Bosch is prohibited.

*All other trademarks are property of their respective owners.

WARRANTY AND SERVICE INFORMATION

For warranty and service information, refer to the appropriate web site below:

- RTS Intercoms www.rtsintercoms.com/warranty
- RTS Digital
- RTSTW
- AudioCom
- RadioCom
- Intercom Headsets

CUSTOMER SUPPORT

Technical questions should be directed to:

Customer Service Department
Bosch Security Systems, Inc.
www.telex.com



TECHNICAL QUESTIONS EMEA

Bosch Security Systems Technical Support EMEA

http://www.rtsintercoms.com/contact_main.php

DISCLAIMER

The manufacturer of the equipment described herein makes no expressed or implied warranty with respect to anything contained in this manual and shall not be held liable for any implied warranties of fitness for a particular application or for any indirect, special, or consequential damages. The information contained herein is subject to change without prior notice and shall not be construed as an expressed or implied commitment on the part of the manufacturer.

	CAUTION RISK OF ELECTRIC SHOCK DO NOT OPEN	
THE LIGHTNING FLASH AND ARROWHEAD WITHIN THE TRIANGLE IS A WARNING SIGN ALERTING YOU OF "DANGEROUS VOLTAGE" INSIDE THE PRODUCT.	CAUTION: TO REDUCE THE RISK OF ELECTRIC SHOCK, DO NOT REMOVE COVER. NO USER-SERVICEABLE PARTS INSIDE. REFER SERVICING TO QUALIFIED SERVICE PERSONNEL.	THE EXCLAMATION POINT WITHIN THE TRIANGLE IS A WARNING SIGN ALERTING YOU OF IMPORTANT INSTRUCTIONS ACCOMPANYING THE PRODUCT.
SEE MARKING ON BOTTOM/BACK OF PRODUCT.		

WARNING: APPARATUS SHALL NOT BE EXPOSED TO DRIPPING OR SPLASHING AND NO OBJECTS FILLED WITH LIQUIDS, SUCH AS VASES, SHALL BE PLACED ON THE APPARATUS.

WARNING: THE MAIN POWER PLUG MUST REMAIN READILY OPERABLE.

CAUTION: TO REDUCE THE RISK OF ELECTRIC SHOCK, GROUNDING OF THE CENTER PIN OF THIS PLUG MUST BE MAINTAINED.

WARNING: TO REDUCE THE RISK OF FIRE OR ELECTRIC SHOCK, DO NOT EXPOSE THIS APPARATUS TO RAIN OR MOISTURE.

WARNING: TO PREVENT INJURY, THIS APPARATUS MUST BE SECURELY ATTACHED TO THE FLOOR/WALL/RACK IN ACCORDANCE WITH THE INSTALLATION INSTRUCTIONS.

~	This product is AC only.
---	--------------------------

CE	
----	--

Important Safety Instructions

1. Read these instructions.
2. Keep these instructions.
3. Heed all warnings.
4. Follow all instructions.
5. Do not use this apparatus near water.
6. Clean only with dry cloth.
7. Do not block any ventilation openings. Install in accordance with the manufacturer's instructions.
8. Do not install near any heat sources such as radiators, heat registers, stoves, or other apparatus (including amplifiers) that produce heat.
9. Do not defeat the safety purpose of the polarized or grounding-type plug. A polarized plug has two blades with one wider than the other. A grounding type plug has two blades and a third grounding prong. The wide blade or the third prong are provided for your safety. If the provided plug does not fit into your outlet, consult an electrician for replacement of the obsolete outlet.
10. Protect the power cord from being walked on or pinched particularly at plugs, convenience receptacles, and the point where they exit from the apparatus.
11. Only use attachments/accessories specified by the manufacturer.
12. Use only with the cart, stand, tripod, bracket, or table specified by the manufacturer, or sold with the apparatus. When a cart is used, use caution when moving the cart/apparatus combination to avoid injury from tip-over.
13. Unplug this apparatus during lightning storms or when unused for long periods of time.
14. Refer all servicing to qualified service personnel. Servicing is required when the apparatus has been damaged in any way, such as power-supply cord or plug is damaged, liquid has been spilled or objects have fallen into the apparatus, the apparatus has been exposed to rain or moisture, does not operate normally, or has been dropped.

Table of Contents

INTRODUCTION	11
Features	11
Specifications	12
DKP-4016/4016W Block Diagram	14
Reference View – DKP-4016/4016W	15
Connector Pinouts	16
INSTALLATION	19
Requirements	19
DKP-4016 Installation	20
Connecting the Keypanel to the Intercom	21
Power Up	24
Address Setting	25
Connections	26
Footswitch Cabling	29
BASIC OPERATION	31
Intercom Keys and Displays	31
Keypad Reference View	35
INFO button	39
Breadcrumb Menu Navigation	40
Menu Navigation and Shaft Encoder Knobs	40
CLR Button	41
Basic Intercom Key Operation	41
Key Gain Adjustment	43
Keypanel Volume Adjustments	44
Aux Volume Adjustments	47
Priority Call Volume Control	49
Operation of Intercom Keys with Auto Functions	51
Operation of Intercom Keys with Options	52
Operation of Intercom Talk Keys with the Speaker DIM Setting	52
Operation of Intercom Keys assigned to TIF Ports	53
User Quick Select Scrolling	53
Graphical Call Waiting Window	54
Mute the Microphone/Speaker	56

Mic Select	56
Setup Pages	58
Menu Passwords	59
Voice Messaging (Audio Package Only)	59
User Programmable Buttons	64
Keypanel Color Window	66
Enhanced Tallies	74
Flash Text Characteristics Window	78
Show Icon Characteristics Window	80
Panel Tally	83
Create and Download New Icons	84
Keypanel Mirroring (Control Package Only)	86
Real-Time Control in AZedit (Control Package Only)	89
Keypanel Configuration (Control Package Only)	99
<i>FIRMWARE DOWNLOAD</i>	<i>151</i>
Download Firmware to the DKP-4016/4016W From AZedit	151
Download Firmware to the Keypanel Using the Firmware Upload Tool	153
Enable Downloading New Bootloader from the Keypanel	155
Download Firmware Using the Bootloader	155
Display the FPGA Version on the Keypanel	159
Download and Upgrade the FPGA to the DKP-4016/4016W	159
Download a Splash Screen	163
Download a Font File	165
Download an Icon File	167
Download User Chimes (Control Package Only)	169
Download Screen Savers (Control Package Only)	171
<i>DKP-4016 MENU SYSTEM</i>	<i>175</i>
Main Menu Access	175
Menu System, Audio Options	177
Menu System, Display	204
Menu System, Key Assign Menu	208
Menu System, Key Options Menu	212
Menu System, OMNEO Offers	222
Menu System, RVON Offers (Only available when an RVON-IO is detected)	223
Menu System, Save Config	223
Menu System, Service	224
<i>TELEPHONE INTERFACE (TIF) OPERATION</i>	<i>245</i>
Receiving A Phone Call	245
Dialing and Hanging Up	245
Centralized Auto Dials	247
<i>KEYPAD QUICK REFERENCE</i>	<i>251</i>
Keypad Sequence Introduction	251

KEYPANEL MENU QUICK REFERENCE	255
Audio Options	255
Display Menu	262
Key Assign Menu	263
Key Options Menu	264
OMNEO Offers Menu	267
Save Config Menu	267
Service Menu	268
Unicode Support	271
AZedit and Unicode Support	271
Wall Mounting Option	275
Wall Mount Instructions	275
Audio and Control Packages	279
Audio and Control Add-On Packages	279
Download License Files	280

List of Figures

FIGURE 1.	DKP-4016/4016W Audio Flow Block Diagram	14
FIGURE 2.	DKP-4016/4016W Reference View	15
FIGURE 3.	DKP-4016 Installation	20
FIGURE 4.	Footswitch Cabling and Wiring	29
FIGURE 5.	DKP-4016 Keypad	36
FIGURE 6.	Breadcrumb Navigation	40
FIGURE 7.	Key Function Position Explanation	41
FIGURE 8.	Talk/Listen Indicators	42
FIGURE 9.	Incoming Priority Call Volume Control Keypanel	49
FIGURE 10.	Graphical Call Waiting Window	54
FIGURE 11.	Graphical Call Waiting Window Highlighted Call	55
FIGURE 12.	VM Button	61
FIGURE 13.	VM Playback Menu	62
FIGURE 14.	Voice Message Menu	62
FIGURE 15.	Keypanel Colors Window	66
FIGURE 16.	Color Grid	68
FIGURE 17.	Key Assignments Page	69
FIGURE 18.	Assignments Groups Page	71
FIGURE 19.	Miscellaneous Colors Page	73
FIGURE 20.	Flash Text Characteristics Window	78
FIGURE 21.	Show Icon Characteristic Window	80
FIGURE 22.	512 x 64 pixel bitmap of key overlay icons	84
FIGURE 23.	512 x128 pixel bitmap of panel icons	85
FIGURE 24.	Real Time Warning Message	91
FIGURE 25.	When Ganged Volumes are Configured	94
FIGURE 26.	Keypanel Configuration – Panel Options	101
FIGURE 27.	Panel Options Page – Panel Swap Group Box	102
FIGURE 28.	Panel Options Page – UPG Key Definition Group Box	103
FIGURE 29.	Panel Options Page – Quick-Assign Listen Assignments Group Box	104
FIGURE 30.	Panel Options Page – Panel Mode Group Box	104
FIGURE 31.	Panel Options Page – Miscellaneous Group Box	105
FIGURE 32.	Panel Options Page – Snoop Tally Group Box	105
FIGURE 33.	Panel Options Page– GPI Input Assignments Group Box	106
FIGURE 34.	Panel Options Page – GPI Output Assignments Group Box	106
FIGURE 35.	Panel Options Page – Footswitch Mode Group Box	107
FIGURE 36.	Keypanel Configuration – Display Page	108
FIGURE 37.	Display Page – Keypad Backlight Group Box	109
FIGURE 38.	Display Page – Key Display Options Group Box	110

FIGURE 39.	Display Page – Panel Display Options Group Box	110
FIGURE 40.	Display Page – CWW Options	111
FIGURE 41.	Display Page – LCD Backlight Group Box	111
FIGURE 42.	Display Page – Screen Saver Group Box	112
FIGURE 43.	Keypanel Configuration – Key Options Page	113
FIGURE 44.	Key Options Page – Solo and Exclusive Keys Group Box	114
FIGURE 45.	Key Options Page – Latch Disable Group Box	116
FIGURE 46.	Key Options Page – Button Lock Group Box	117
FIGURE 47.	Key Options Page – Tallies Group Box	118
FIGURE 48.	Key Options Page – Autodial Numbers Group Box	119
FIGURE 49.	Key Options Page – One-Touch Autodials Group Box	120
FIGURE 50.	Key Options Page – Key Groups Group Box	121
FIGURE 51.	Key Options Page – Chimes Group Box	122
FIGURE 52.	Key Options Page – Key Icons Group Box	123
FIGURE 53.	Key Options Page – Key Volumes Group Box	123
FIGURE 54.	Keypanel Configuration – Audio Options	125
FIGURE 55.	Audio Options Page – Mic Modes Group Box	126
FIGURE 56.	Audio Options Page – Speaker / Headset Modes Group Box	126
FIGURE 57.	Audio Options Page – Aux Inputs Group Box	127
FIGURE 58.	Audio Options Page – Mic Options Group Box	129
FIGURE 59.	Audio Options Page – Matrix Out and Sidetone Options Group Box	130
FIGURE 60.	Audio Options Page – Headset Configuration Group Box	131
FIGURE 61.	Audio Options Page – Ganged Volumes Group Box	131
FIGURE 62.	Audio Options Page – Tone Generator Group Box	132
FIGURE 63.	Audio Options Page – VM Options Group Box	132
FIGURE 64.	Keypanel Configuration – Audio Levels	133
FIGURE 65.	Audio Levels Page – Input Volumes Group Box	134
FIGURE 66.	Audio Levels Page – Output Volumes Group Box	135
FIGURE 67.	Audio Levels Page – Output Dim Amounts Group Box	135
FIGURE 68.	Audio Levels Page – Minimum Input Volumes	136
FIGURE 69.	Audio Levels Page – Minimum Output Volumes Group Box	137
FIGURE 70.	Audio Levels Page – Maximum Output Volumes Group Box	137
FIGURE 71.	Audio Levels Page – Chime Volumes Group Box	138
FIGURE 72.	Keypanel Configuration – Advanced	139
FIGURE 73.	Advanced Page – AGC Group Box	140
FIGURE 74.	Advanced Page – Mixing Group Box	141
FIGURE 75.	Advanced Page – Compression Group Box	142
FIGURE 76.	Advanced Page – Gating Group Box	143
FIGURE 77.	Advanced Page – Noise Gate Group Box	144
FIGURE 78.	Keypanel Configuration – Filters Page	145
FIGURE 79.	Filters Page – Input Bandpass Filters Group Box	146
FIGURE 80.	Filters Page – Output Bandpass Filters Group Box	147
FIGURE 81.	Filters Page – Input Equalization Filters Group Box	148
FIGURE 82.	Filters Page – Output Equalization Filters Group Box	149
FIGURE 83.	Filters Page – Notch Filter Mode Selection	150
FIGURE 84.	Automatic Gain Control Example	179

The DKP-4016/4016W series keypanels delivers superior high-quality digital audio using OMNEO technology from Bosch with Dante audio over IP via either copper or fiber. The DKP-4016/4016W series keypanels delivers audio, free of noise, delay, and other artifacts present in legacy technology. This family of keypanels includes a rich set of connectors as standard, including **GPIO** (General Purpose Input and Output) and **RC** (Rear Connector) kit. As with other RTS products, emphasis is placed on backward compatibility with previous generations of matrices including analog technology.

The DKP-4016/4016W series utilizes the latest generation of wide angle TFT displays providing superior clarity, resolution, and longer display life delivering high-quality readability under a variety of lighting conditions.

Optionally, there are two (2) packages (Control and Audio) with additional features and functions, such as voice message, real-time control, keypanel mirroring, etc. For more information on these packages, see “Audio and Control Packages” on page 279.

Features

- Superior digital, high-quality audio over IP (Internet Protocol) included through OMNEO technology, the branded IP-based solution from Bosch.
- Advanced signal processing, delivering an audio experience, free of noise, echo, delay and other artifacts present in legacy technology.
- Backward compatible with legacy technologies, such as analog audio in USOC and 568-B formats.
- All previous optional hardware connectors (RC, GPI, etc) are now standard.
- New wide-angle high-definition display.
- Enhanced keypanel menus optimized for ease of use.
- For an additional price each, an Audio and/or Control add-on package is available for the DKP-4016/4016W, to greatly expand your keypanel and intercom system experience and capabilities. For more information on these packages, see “Audio and Control Packages” on page 279.

Specifications

LCD Display DKP-4016/4016W

Active Area	120.10 mm (wide) x 35.86 mm (high)
Dot Resolution.....	576 x 172 pixels
Color Resolution	16-bit (64K) RGB color
View Angle.....	80 degrees (typical; all directions)

Power Supply:

Type:.....	Internal
AC Input:.....	100–240 VAC 50/60 Hz

General Purpose Inputs and Outputs: Outputs

Type (relays).....	SPDT
Contact Rating.....	1AMP @ 30VDC

Inputs

Type.....	Optically Coupled
Input Voltage	5-18 VDC on A+

◆A+ is internally pulled to 5VDC. Connect K- to  to activate.◆

Inputs: Matrix

Type.....	Balanced
Typical Input Level	+8 dBu
Typical Input Impedance.....	20 kΩ
Maximum Input Level.....	+20 dBu
Supported Bandwidth.....	100 Hz to 20 kHz

AUX

Type.....	Balanced
Typical Input Level	+8 dBu
Typical Input Impedance.....	20 kΩ
Maximum Input Level.....	+20 dBu
Supported Bandwidth.....	100 Hz to 20 kHz

Front Panel Mic

Type	Electret
Typical Input Level.....	-42 dBu
Typical Input Impedance	1 kΩ
Maximum Input Level.....	-25 dBu

Rear Panel Mic

Type	Electret
Typical Input Level.....	-42 dBu
Typical Input Impedance	1 kΩ
Maximum Input Level.....	-25 dBu

Left and Right Headset Mic - Electret

Typical Input Level.....	-42 dBu
Typical Input Impedance	1 kΩ
Maximum Input Level.....	-25 dBu

Left and Right Headset Mic - Dynamic

Typical Input Level.....	-50 dBu
Typical Input Impedance	600 Ω
Maximum Input Level.....	-25 dBu

Outputs: Matrix

Type	Balanced
Typical Output Level	+8 dBu
THD+N%.....	<0.20%
Typical Output Impedance.....	600 Ω
Maximum Output Level	+20 dBu
Frequency Response	100 Hz to 20 kHz

MIC/LINE Out

Type	Balanced
Typical Output Level	+8 dBu
THD+N%.....	<0.20%
Typical Output Impedance.....	600 Ω
Maximum Output Level	+20 dBu
Frequency Response	100 Hz to 20 kHz

Headset - Left, Right

Maximum Output Power	125 mW for 32 Ω load
Earphone Impedance	16 Ω and above
THD+N%	<0.20%
Frequency Response	20 Hz to 20 kHz

Speaker - Rear

Maximum Output Power	5 W for 8 Ω load
Speaker Impedance	4 Ω and 8 Ω
THD+N%	<0.20%
Frequency Response	20 Hz to 20 kHz

Digital:**OMNEO Channels**

Typical OMNEO Latency	1 ms
Frequency Response	20 Hz to 20 kHz

Environmental:**Dimensions****DKP-4016/4016W**

3.60 in. H x 10.63 in. W x 9.35 in. D
(91.5 mm H x 270.1 mm W x 237.6 mm D)

Weight

DKP-4016/4016W	3.70 lb. (1.68 kg)
----------------------	--------------------

Temperature

Operating	0° C to 55° C (32° F to 131° F)
Storage	-20° C to 70° C (-4° F to 158° F)

Power Consumption:**DKP-4016/4016W**

Nominal	25 Watts
Maximum	39 Watts
Maximum Volt Amp	63 VA

Certification:**CE Compliance**

- EMC
- EN55022 Class A
- VCCI Class A
- ICES-003
- FCC Part 15 Subpart B Class A
- AS/NZS CISPR22 Class A
- Korean KN 22
- EN 55024
- Korean KN 61000-4
- BSMI Class B

Safety

- UL 60950-4
- EN60950-1
- CB Report
- PSE

DKP-4016/4016W Block Diagram

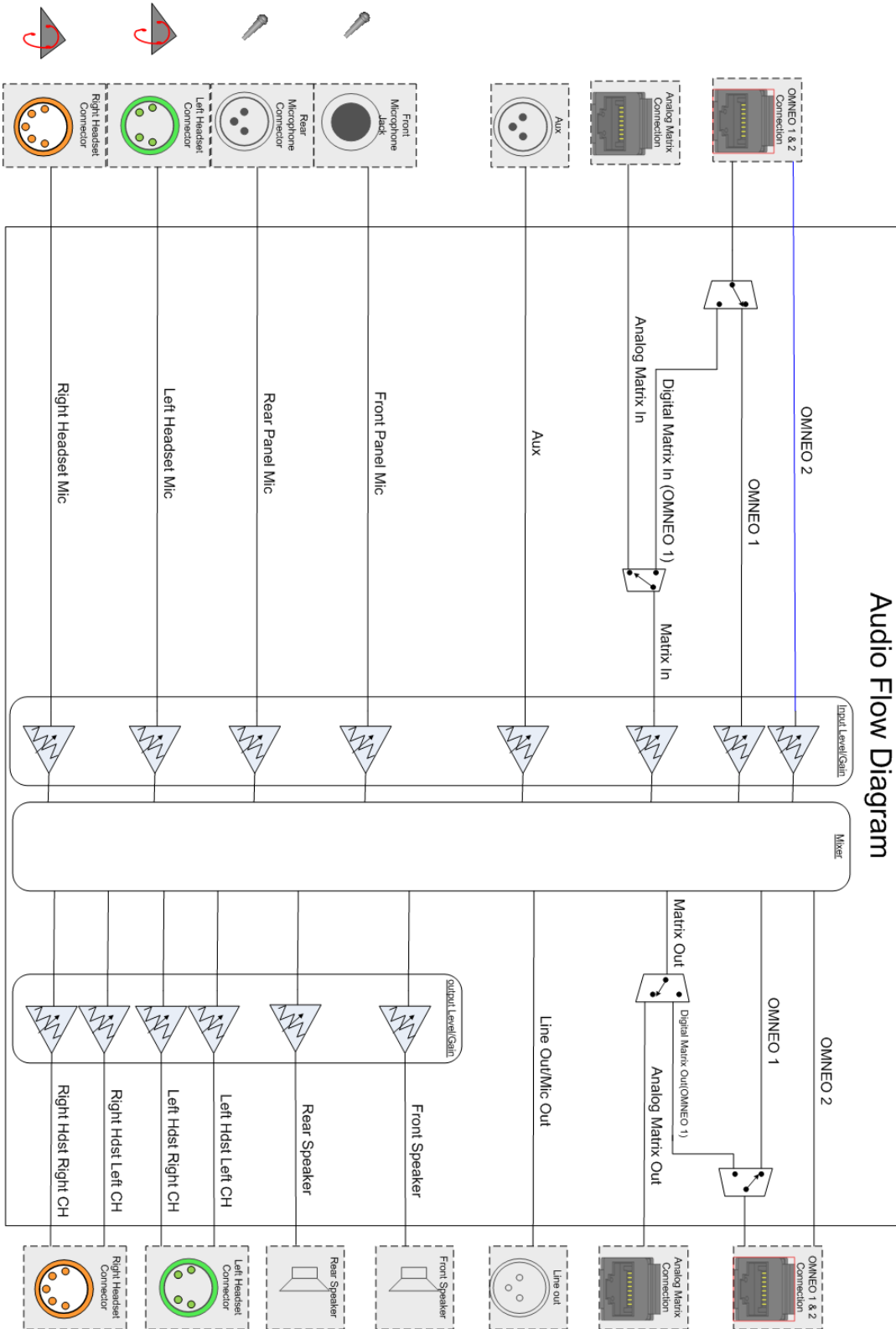

FIGURE 1. DKP-4016/4016W Audio Flow Block Diagram

a. Additionally licensed OMNEO channels 3-8 not shown.

Reference View – DKP-4016/4016W

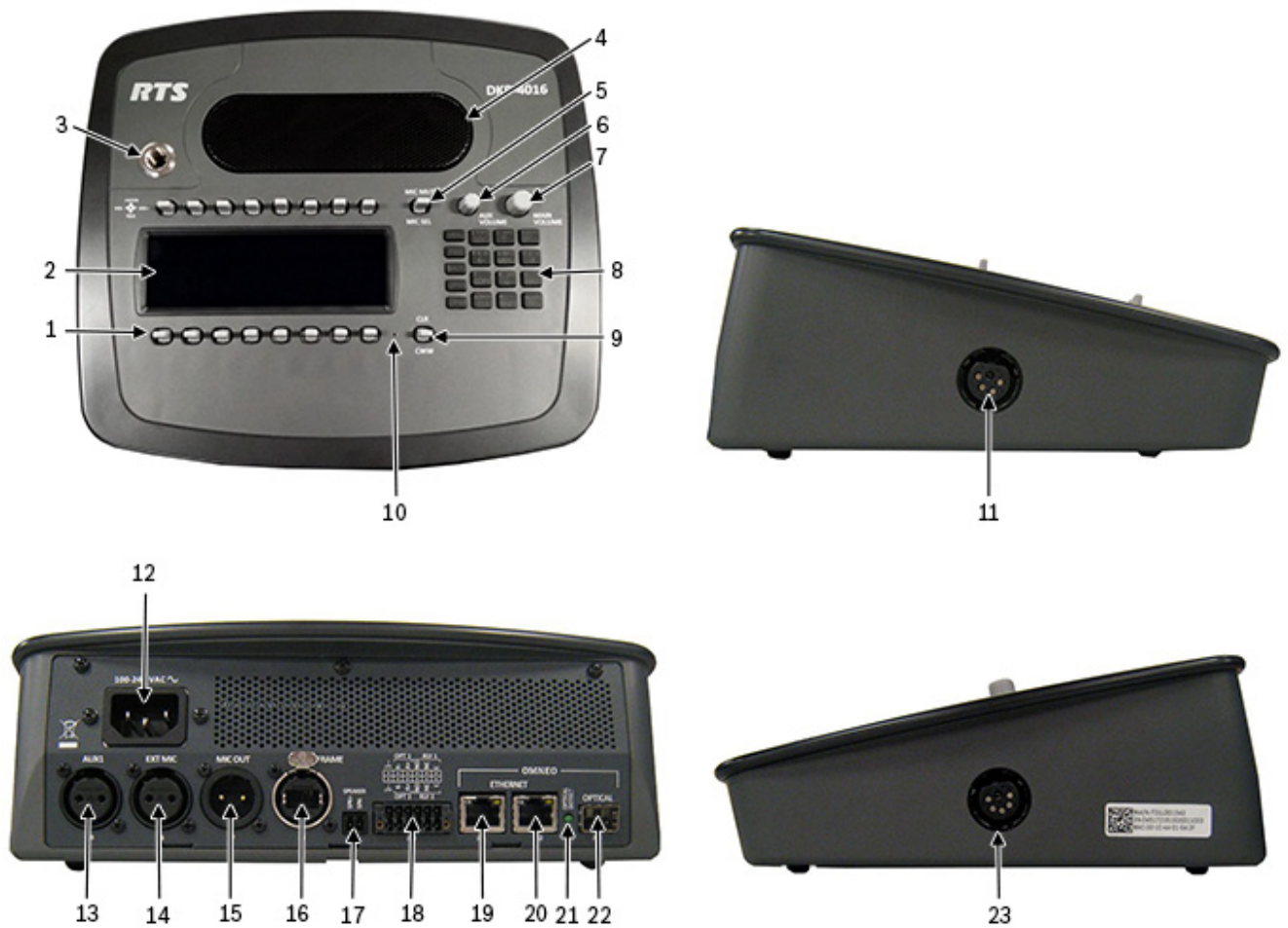

FIGURE 2. DKP-4016/4016W Reference View

- | | |
|--|---|
| 1. Multi-Directional Lever Keys | 16. FRAME Connector |
| 2. High Resolution, Wide-Angle LCD Display | 17. SPEAKER Connector (2-position Terminal Block) |
| 3. Microphone Connector | 18. GPIO Connector (12-position Terminal Block) |
| 4. Front Speaker | 19. OMNEO ETHERNET Connector |
| 5. MIC MUTE/MIC SEL Lever Key | 20. OMNEO ETHERNET Connector |
| 6. AUX VOLUME Knob | 21. OMNEO OPTICAL (fiber) Indicator LED |
| 7. MAIN VOLUME Knob | 22. OMNEO OPTICAL (fiber) Connector |
| 8. Keypad | 23. 5-pin Headset Connector |
| 9. CLR/CWW Lever Key | |
| 10. User Reset Hole | |
| 11. 4-pin Headset Connector | |
| 12. AC Power | |
| 13. AUX1 Connector | |
| 14. EXT MIC Connector | |
| 15. MIC OUT Connector | |

Connector Pinouts

Rear Speaker: J2	
Pin	Assignment
Pin 1	Rear Speaker -
Pin 2	Rear Speaker +

Aux1: J3	
Pin	Assignment
Pin 1	GND
Pin 2	AUX 1 IN +
Pin 3	AUX 1 IN -

Right Headset: J5 (Wallmount version – J15)	
Pin	Assignment
1	RIGHT_HS_MIC_IN -
2	RIGHT_HS_MIC_IN +
3	RIGHT_HS_COMMON
4	RIGHT_HS_L_OUT
5	RIGHT_HS_R_OUT

Left Headset: J15 (Wallmount version – J5)	
Pin	Assignment
1	LEFT_HS_MIC_IN -
2	LEFT_HS_MIC_IN +
3	LEFT_HS_COMMON
4	LEFT_HS_L_OUT

Rear Panel Mic: J6	
Pin	Assignment
1	REAR_PANEL_MIC_IN -
2	REAR_PANEL_MIC_IN +
3	GND

MIC OUT/LINE OUT: J7	
Pin	Assignment
1	GND
2	MIC_OUT/LINE_OUT +
3	MIC_OUT/LINE_OUT -

Matrix Connector: J8 ^a		
Pin	RJ-45	RJ-12
1	RS485 +	
2	RS485 -	RS485 -
3	FROM MATRIX +	FROM MATRIX +
4	TO MATRIX +	TO MATRIX +
5	TO MATRIX -	TO MATRIX -
6	FROM MATRIX -	FROM MATRIX -
7	RS485 +	RS485 +
8	RS485-	

a. Supports 568B and USOC wiring

GPIO Connector: J10	
Pin	Assignment
1	Chassis GND
2	OPTO2_CATHODE
3	OPTO2_ANODE
4	RELAY2_NO
5	RELAY2_NC
6	RELAY2_COM
7	Chassis GND
8	OPTO1_CATHODE
9	OPTO1_ANODE
10	RELAY1_NO
11	RELAY1_NC
12	RELAY1_COM

ETHERNET: J11	
Pin	Assignment
1	Data 1 +
2	Data 1 -
3	Data 2 +
4	Data 3 +
5	Data 3 -
6	Data 2-
7	Data 4+
8	Data 4-

ETHERNET: J12	
Pin	Assignment
1	Data 1 +
2	Data 1 -
3	Data 2 +
4	Data 3 +
5	Data 3 -
6	Data 2-
7	Data 4+
8	Data 4-

Front Panel Mic	
Pin	Assignment
Tip	REAR_PANEL_MIC_IN +
Ring	REAR_PANEL_MIC_IN -
Sleeve	CGND

Requirements

The following keypanel firmware versions are needed for the specified DKP-4016/4016W model:

AZedit..... V5.2.0 or later

IPedit..... V3.2.3 or later

MCH-e..... V3.4.0 or later

AIO-16..... V1.7.0 or later

FWUT..... V4.20.3586 or later

DNS-SD..... V4.20.3586 or later

OMI..... V5.2.12 or later

DKP-4016 Installation

IMPORTANT: For DKP-4016W wall mounting instructions, see “Wall Mounting Option” on page 275.

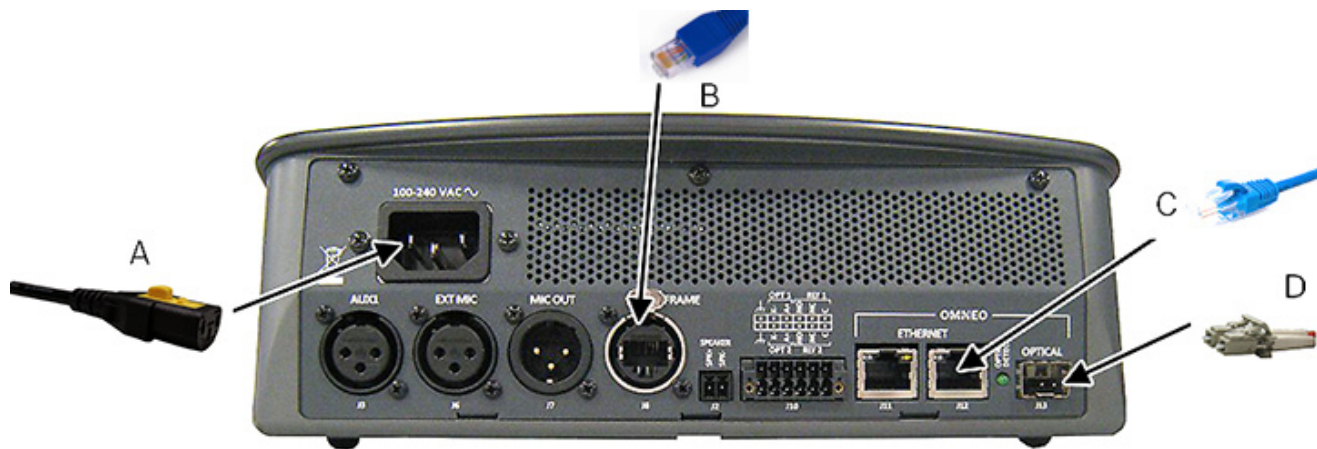

FIGURE 3. DKP-4016 Installation

To **install the DKP-4016**, do the following:

1. On the rear panel of the DKP-4016, plug the **AC power cord (A)** into the power connector on the back panel of the unit.
2. Connect an **RJ-12 or RJ-45 (USOC or 568B) cable (B)** with RTS cabling to the J8 FRAME connector.
OR
Connect an **CAT-5e cable (C)** to either J11 or J12 ETHERNET connector.

NOTE:

- If you have the option J13 fiber connector installed, connect a **fiber connector (D)** to the OPTICAL fiber connector on the rear panel.
 - The KP-Series panels can have both AIO and Ethernet connected simultaneously, and the user can switch between connections using the menus.
3. Once the unit is cabled, plug the **AC power cord** into the wall outlet or a power strip.

Connecting the Keypanel to the Intercom

You can configure the OMI using AZedit and IPedit; however, only IPedit can be used to configure the keypanel.

Configure the OMI using AZedit

To **configure the OMI to the DKP-4016/4016W using AZedit**, do the following:

1. From the Status menu in AZedit, select **I/O Cards**.
The I/O Card Status window appears showing a list of installed cards.
2. Right-click the **OMI card** you want to configure to the keypanel.
A pop-up menu appears.
3. From the pop-up menu, select **OMNEO Configuration**.
The OMNEO Configuration window appears.
4. From the OMNEO card drop down menu, select the **slot number** where the OMI card is located in the frame.
The Device Name field auto-populates with the name of the device.
5. From the Local Channel drop down menu, select the **channel** you want to use to communicate to your keypanel across the network.

NOTE: Channels not already configured to connect to another device appear with an asterisk (*) next to them.

6. In the Partner Device Name field, enter the **name of keypanel** you want to use to communicate with or select the **Browse icon** to select from a list of devices.
OR
In the Partner IP Address field, enter the **IP Address** of the device to which you want to connect. This field auto-populates when you select the Device Name.
7. From the Partner Device Type drop down menu, select the **type of device** to which the OMI card is connecting.
8. From the Partner Channel drop down menu, select the **channel** on the device to which the OMI communicates.
9. Once you are completely finished, click **Apply**.
Apply sends all the changes to all the cards in the intercom, or Click Cancel to discard all the changes made.

Add the OMI to the Device Catalog in IPedit

To **add the OMI to IPedit**, do the following:

1. Open **IPedit**.
2. From the Device menu, select **Add**.
The Add Devices Window appears, open to the Search tab.
3. Select the **OMI card**.
The Add button becomes active.
4. Click the **Add button**.
The OMI card appears in the device catalog in the left panel.
5. Click the **Done button**.
The Add Devices window closes.

Configure the OMI using IPedit

To **configure the OMI using IPedit**, do the following:

Using the Device Configuration and Status Pane

1. In the Device Name field, enter a **device name** familiar to you.
Initially, OMI cards are given a default name.

IMPORTANT: If you change the device name, this causes the device to reboot. It is not necessary to change the device name. However, if you do change the name, it is best to do this early in the setup so you do not have to revisit other devices that connect to this device and update them later.

2. In the Description field, enter a **description for the OMI card**, if desired.

Using the Channel Configuration and Status Section:

3. In the Channel Description field, enter a **channel description**, if applicable.
4. From the Destination Type drop down menu, select **OKP**.

NOTE: The Destination Type does not need to be selected if using the Browse window to select the device. It fills the type and IP Address automatically. The type is either OKP-2 or OKP-8 depending on the license for 2 or 8 OMNEO channels.

5. In the Destination Device Name field, enter the **name of the device** to which the channel will connect.
OR
Click the ... button.
The Discovered Devices Window appears.
Expand the **tree** to view the destination devices available.
From the expanded tree, select the **device** you want for your destination device.
Click **OK**.
6. From the Destination Channel drop down menu, select the **channel** to which the OMI will connect.
7. Send the changes to the OMI.

Add the DKP-4016/4016W to the Device Catalog in IPedit

To **add the keypanel to IPedit**, do the following:

1. Open **IPedit**.
2. From the Device menu, select **Add**.
The Add Devices Window appears, open to the Search tab.
3. Select the **keypanel**.
The Add button becomes active.
4. Click the **Add button**.
The OKP-2/8 appears in the device catalog in the left panel.
5. Click the **Done button**.
The Add Devices window closes.

Configure the DKP-4016/4016W using IPedit

To **configure the keypanel using IPedit**, do the following:

Using the Device Configuration and Status Pane

1. In the Device Name field, enter a **device name** familiar to you.
Initially, keypanels are given a default name.

IMPORTANT: If you change the device name, this causes the device to reboot. It is not necessary to change the device name. However, if you do change the name, it is best to do this early in the setup so you do not have to revisit other devices that connect to this device and update them later.

2. In the Description field, enter a **description for the keypanel**, if desired.

Using the Channel Configuration and Status Section:

3. In the Channel Description field, enter a **channel description**, if applicable.
4. From the Destination Type drop down menu, select **OMI**.

NOTE: The Destination Type does not need to be selected if using the Browse window to select the device. It fills the type and IP Address automatically. The type can be OMI-16, OMI-332, OMI-48, or OMI-64 depending on the license.

5. In the Destination Device Name field, enter the **name of the device** to which the channel will connect.
OR
Click the ... button.
The Discovered Devices Window appears.
 - a. Expand the **ree** to view the destination devices available.
 - b. From the expanded tree, select the **device** to which you want to connect this keypanel.
 - c. Click **OK**.
6. From the Destination Channel drop down menu, select the **channel** to which the keypanel will connect.
7. Send the changes to the keypanel.

Connecting the DKP-4016/4016W through the OMNEO Offers Menu

IMPORTANT: If you used IPedit to set up the keypanel connection, this step is not needed, because you have already done this in the software.

To finish the configuration, you must configure the keypanel to talk with the OMI card in the frame. To do this, you must establish a connection using the OMNEO Offers menu on the keypanel. For more information, see “Menu System, OMNEO Offers” on page 222.

To **configure an available OMNEO device connection port**, do the following:



1. Starting at the OMNEO Offers|Keypanel menu, select **OKP**.
2. Press the **SEL button**.
A list of available OMNEO offers appear.
3. Using the arrow buttons, select the **OMNEO offer** you want to use.
An arrow appears next to the device.
4. Press the **CLR button** to exit menu mode.

Power Up

At power-up, if the keypanel is connected to the matrix, the alphanumeric display shows dashes in the light blue color key



. After several seconds, the intercom key assignments display with the appropriate color keys and alphas.

NOTE: If the keypanel cannot establish communications with the intercom system, all alphanumeric displays continue to show asterisks (****) and the *Disconnected from Matrix* icon  appears in the panel display. If the keypanel is configured for OMNEO, this icon also displays the OMNEO device name. Check the keypanel to matrix cable connection if this occurs. If the keypanel loses communications with the intercom, the panel display shows the Disconnected from Matrix icon and displays the  after approximately 30 seconds.

Address Setting

General Information

In ADAM intercoms using AIO-8 cards or AIO-16 cards with SCSI breakouts, and in ADAM-CS and Zeus/Zeus II intercoms, the intercom ports share data connections in groups of eight (8). Each keypanel is uniquely identified on the data port by its address. The method of determining the proper address varies for each intercom system. Use the method for your intercom system, as described on the following pages.

TABLE 1. DKP-4016/4016W Addressing

Manually Addressed	Automatically Addressed
<p>You must manually address^a the keypanel when using the following:</p> <ul style="list-style-type: none"> • AIO-8 on ADAM • AIO-16 SCSI on ADAM • ADAM CS • Zeus I • Zeus II 	<p>The keypanel address is automatically detected when using the following:</p> <ul style="list-style-type: none"> • AIO-16 MDR on ADAM and ADAM-M • Cronus • Zeus III and Zeus III LE/LE+ • RVON Products - RVON-8, RVON-2, RVON-C, and RVON-16 <p>NOTE: Keypanels using RVON-I/O may need to be individually addressed. See the RVON-I/O user manual for further instruction.</p>

a. To manually address the DKP-4016/4016W, see “Service Menu, Set Address” on page 240.

To see specific addressing information for:

- ADAM with AIO-8 cards, see the ADAM technical manual (P/N F01U216986).
- ADAM CS, see the ADAM CS technical manual (P/N 93307517000).
- ADAM and ADAM-M with AIO-16 cards, see the AIO-16 user manual (P/N F01U193267).
- Cronus, see Cronus user manual (P/N F01U118890).
- Zeus III, see the Zeus III user manual (P/N F01U193289).
- Zeus III LE/LE+, see the Zeus III LE/LE+ user manual (P/N F01U193290).

NOTE: If you are connecting to an ADAM or ADAM-M frame with AIO-16 cards using MDR connectors or a Cronus frame, you do not need to set the address. If the AIO-16 is using SCSI breakouts, you must set the address.

Connections

Frame Connector

Use the Frame connector to connect to an intercom port of the intercom system. For the frame connector location, see Figure 2 on page 15. The intercom port you connect to should agree with the address you set previously.

Ethernet Connector

Use the Ethernet connector to connect the keypanel to a network system. Each RJ-45 Ethernet connector has two (2) LEDs:

Left LED. The left LED is yellow and indicates a network link is established. It flashes on/off whenever there is network activity.

Right LED. The right LED is bi-color (orange and green) and indicates the speed of the connection by the color that is displayed.

- A green LED indicates the port is operating at 1000Mbps (1 Gbps).
- An orange LED indicates the port is operating at 100Mbps.
- No LED color indicates the port is operating at 10Mbps. This is not suitable for OMNEO networking.

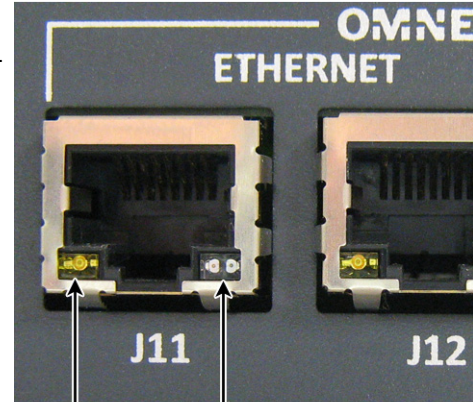

Left LED (yellow) **Right LED (bi-color orange/green)**

Panel Microphone Connector

A panel microphone may be connected to the front or rear of the unit. The connector accepts MCP5, MCP6, or MCP90 series panel microphones. Insert the microphone and rotate the entire microphone body clockwise several turns to lock it in place.

GPIO 12-Position Terminal Block Connector

The **GPIO 12-Position Terminal Block Connector** is used to provide connections to relays (outputs) and opto-isolators (inputs). Using the table, “GPIO Connector: J10” on page 17, connect the correct wires to the 12-position connector.

Wire Specifications

Solid Wire: 26-16AWG/0.13–1.5MM²

Stranded Wire: 26-16AWG/0.13–1.5MM²

To **connect the 12-position terminal block connector to the keypanel**, do the following:

1. Align the **terminal block connector with the 12-position connector** on the rear side of the keypanel.
2. Gently push the **connector** into place.
You should see the locking levers lock into place.

To **detach the 12-position terminal block connector from the keypanel**, do the following:

- > Using both thumbs, gently press up on the **locking levers**.
The connector is released from the keypanel.



Speaker 2-Position Terminal Block Connector

The **Speaker 2-Position Terminal Block Connector** is used to connect an external speaker to the keypanel. This may be a speaker in another room or a speaker the user likes to use.

Wire Specifications

Solid Wire: 26-16AWG/0.13–1.5mm²

Stranded Wire: 26-16AWG/0.13–1.5mm²

Torque: 3.0lb-IN/0.34Nm

WARNING: The positive (+) and negative (-) terminals of the connector should be connected to the positive (+) and negative (-) terminals of the external speaker. These terminals should never be connected to GND or permanent damage can occur.

To connect the **2-position terminal block to the keypanel**, do the following:

1. Align the **2-position terminal block connector with the 2-position connector** on the rear side of the keypanel.
2. Gently push the **connector** into place.

To **detach the 2-position terminal block connector from the keypanel**, do the following:

- > Using the thumb and fore-finger, carefully wiggle the **2-position terminal block** until it comes free from the connector.



Footswitch Cabling

A **Footswitch** is a foot activated device used to turn a talk key on or off. There are two (2) steps to cable and configure a footswitch:

- Step 1** Cable the device to the keypanel.
- Step 2** Configure the GPIO as a talk key on the keypanel. See “Service Menu, Local GPIO” on page 232.
OR
Enable the Footswitch in the keypanel menu. See “Service Menu, Footswitch” on page 226.

To **attach a footswitch to the DKP-4016/4016W**, do the following:

1. On the back panel of the DKP-4016/4016W, locate **J10, the 12-position terminal block**.
2. Using Figure 4, cable the **footswitch to OPT 1 at the K- and Chassis ground positions**.

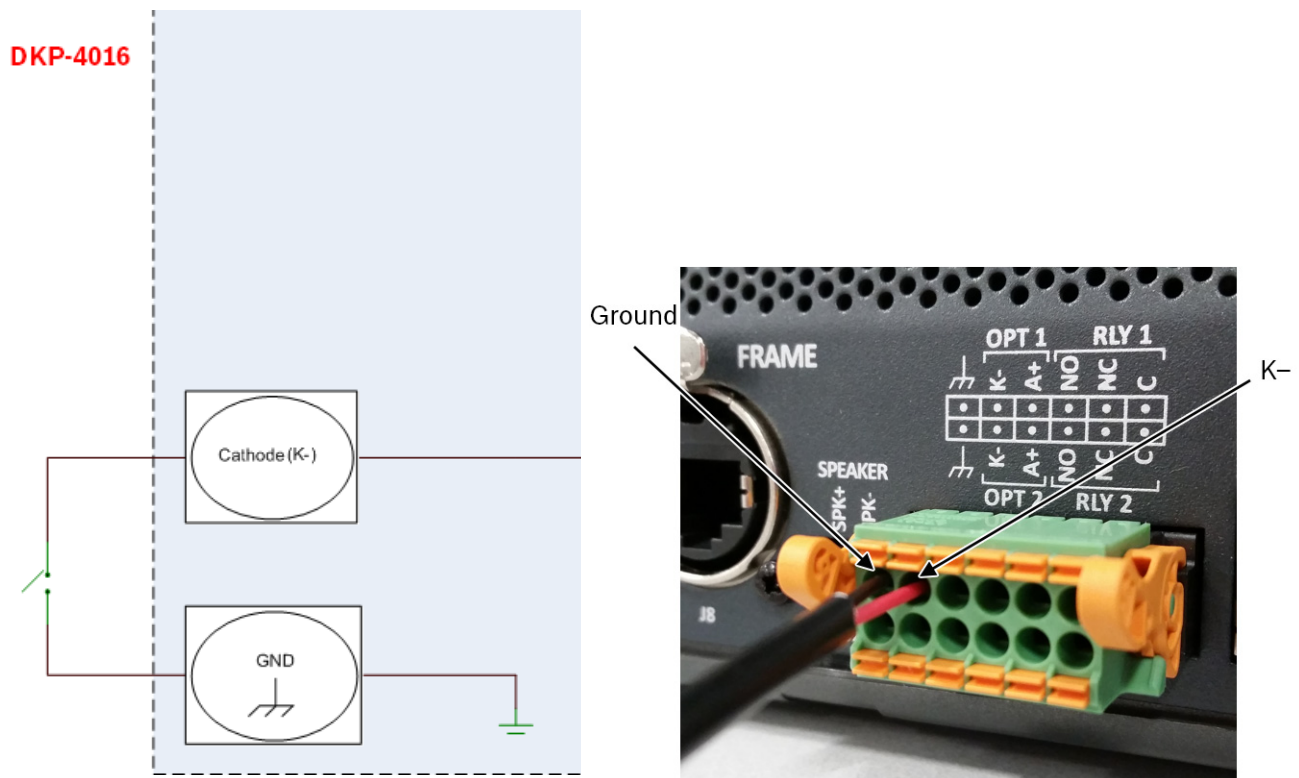















FIGURE 4. Footswitch Cabling and Wiring

*Intercom Keys and Displays***Color Display Descriptions for Intercom Keys**

The DKP-4016/4016W display uses key colors to distinguish the type of key assignment assigned to the key. Use Table 2, to help you determine the available key assignment colors.

TABLE 2. Default Key Colors

Default Color	Description
 Amber	Waiting for Footswitch
 Bright Green	Listen Indicator, Local Matrix
 Brown	IFB Special List
 Teal	Point-to-Point
 Dark Yellow	ISO
 Light Blue	Unassigned, Test Mode (with Talk and Listen Indicators)
 Pale Yellow	Special Functions
 Magenta	Relay
 Pink	Party Line
 Red	Remote Matrix
 Salmon	IFB, Talk Indicator
 Pale Green	Special List
 Periwinkle	UPL Resource

Display Icons

Display Icons are used to indicate the accessories and features enabled, disabled, active, and inactive. Use Table 3 for a complete description of each icon seen on the DKP-4016/4016W.

TABLE 3. Display Icon Descriptions













Icon	Icon Name	Description
	Matrix Connected	The keypanel is connected to the Matrix. This icon briefly displays at connection.
	Disconnected From Matrix	There is no connection between the Matrix and the keypanel. This icon is displayed as long as there is no Matrix data connection. NOTE: When the keypanel is disconnected, it displays its Device Name (for OMNEO) or IP Address (for RVON) device connections.
	Firmware Download	Firmware is being downloaded to the keypanel. A progress bar displays: chunk progress overall progress chunk/overall progress NOTE: For more information, see “Download Firmware to the DKP-4016/4016W From AZedit” on page 151.
	Footswitch Active	The footswitch is active.
	Footswitch Enabled	The footswitch is enabled, but not active. NOTE: When a keypanel key is latched while the Footswitch is enabled, the key display turns amber to signify it is waiting for the footswitch.
	Left Headphones	The left headphones are enabled. This indicates the left headset microphone is not enabled.
	Left Headset	The left headset is enabled.
	Left Headset Mic Muted	The left headset mic is muted.
	Front Microphone	The front microphone is enabled.
	Front Microphone Muted	The front microphone is muted. To mute the front microphone, see “Mute the Microphone/Speaker” on page 56.
	Front Speaker	The front speaker is enabled. To enable the front speaker, see “Audio Options Menu, Speaker” on page 200.
	Front Speaker Muted	The front speaker is muted.
	Right Headphones	The right headphones are enabled. This indicates the right headset mic is not enabled. To enable the rear headphones, see “Audio Options Menu, Headset Speaker” on page 194.

TABLE 3. Display Icon Descriptions





























Icon	Icon Name	Description
	Right Headset	The right headset is enabled.
	Right Headset Muted	The right headset mic is muted.
	Rear Microphone	The rear microphone is active. To activate the rear microphone, see “Audio Options Menu, Panel Mic” on page 199.
	Rear Microphone Muted	The rear microphone is muted. To mute the rear microphone, see “Mute the Microphone/Speaker” on page 56.
	Rear Speaker	The rear speaker is active. To activate the rear speaker, see “Audio Options Menu, Speaker” on page 200.
	Rear Speaker Muted	The rear speaker is muted.
	Both Headphones	Both right and left headphones are enabled. This indicates both the right and left headset mics are disabled. To enable the left headphones, see “Audio Options Menu, Headset Speaker” on page 194.
	Both Headsets	Both right and left headsets are active.
	Both Headsets Muted	Both right and left headset mics are muted.
	Both Microphones	Both front and rear microphones are enabled.
	Both Microphones Muted	Both front and rear microphones are muted. To mute the front microphone, see “Mute the Microphone/Speaker” on page 56.
	Both Speakers	Both front and rear speakers are enabled. To enable the front speaker, see “Audio Options Menu, Speaker” on page 200.
	Both Speakers Muted	Both front and rear speakers are muted.
	Snoop Tally Active	Snoop Tally is Active on the keypanel. You must have the Hot Mic enabled to use snoop tallies. To enable snoop tallies, see “Service Menu, Snoop Tally” on page 241.
	Hot Mic	The hot mic is active. To activate Hot Mic, see “Audio Options Menu, Matrix Out” on page 196.
	Tone 1kHz Enabled	Tone 1kHz is enabled on the keypanel. To enable tone 1kHz, see “Audio Options Menu, Tone Gen” on page 201.

TABLE 3. Display Icon Descriptions

Icon	Icon Name	Description
	Tone 500Hz Enabled	Tone 500Hz is enabled on the keypanel. To enable tone 500Hz, see “Audio Options Menu, Tone Gen” on page 201.
	OMNEO Enabled	The OMNEO matrix interface is enabled on the panel. For more information on OMNEO Offers, see “Menu System, OMNEO Offers” on page 222.
	OMNEO Disabled	The OMNEO matrix interface is disabled on the panel. For more information on OMNEO Offers, see “Menu System, OMNEO Offers” on page 222.
	Virtual Key Assignment	Keys are active on a virtual EKP that are not being displayed. For more information, see “Key Options Menu, Panel Swap” on page 218. NOTE: A talk or listen bar (or both) displays to indicate which type of virtual keys are active.
	AFK	The AFK (Away From Keypanel) icon displays when a user activates AFK mode and steps away from the keypanel. Callers are notified the user is AFK and can then leave a message.
	VM	The Voice Message icon displays when voice messages are present on the keypanel.
	Recording	The Recording icon is shown if an AFK panel is actively recording a message or if the 30-second rolling buffer is enabled.
	Supervisor Mirroring	The Supervisor icon signifies the keypanel is mirroring another keypanel and can make changes to the other keypanel, known as a Target. For more information, see “Service Menu, Mirror (Control Package Only)” on page 234.
	Target Mirrored	The Target icon signifies the keypanel is being mirrored by another keypanel, known as a Supervisor. This keypanel can be taken control of by the Supervisor. For more information, see “Service Menu, Mirror (Control Package Only)” on page 234.
	Matrix In Mute	The Matrix Input volume is muted. When the Matrix Input volume is adjusted down to Mute, the panel displays this flashing icon as a warning that there is no audio from the Matrix.
	Audio Package Installed	The optional audio package is installed. When the Audio package is installed, this icon appears at power-up and continues to display until the keypanel connects to the intercom. For more information, see “Audio and Control Packages” on page 279.
	Control Package Installed	The optional control package is installed. When the control package is installed, this icon appears at power-up and continues to display until the keypanel connects to the intercom. For more information, see “Audio and Control Packages” on page 279.

Keypad Reference View

With the DKP-4016/4016W there are three (3) tiers to the keypad: Primary Mode, SHIFT Mode, and Dial Mode.

Primary Mode

Primary Mode is used for the most common keypad functions, such as CLR, SEL, and accessing the Main menu. There are no special keypad sequences to use these functions.

SHIFT Mode

SHIFT Mode contains secondary functions used to access more functionality. The SHIFT mode function labels are located in the upper-right corner of the keypad key.

NOTE: By default, the keypad backlight changes to *white* when the keypad is in SHIFT mode. For more information, see “Service Menu, Keypad” on page 229.

To **access SHIFT Mode**, do the following:

1. On the keypad, press the **SHIFT button**.
2. On the keypad, press the **SHIFT mode button** desired.

NOTE: Once you enter SHIFT mode, you can exit the mode by pressing the SHIFT key again, without pressing any other keys.

Dial Mode

DIAL Mode is used to complete telephone operations. For more information, see “Telephone Interface (TIF) Operation” on page 245. When the keypanel is in DIAL mode, the keypad keys support the standard telephone DTMF keypad configuration as a third tier function. The DTMF keypad is seen in the upper-left corner of the keypad keys.



FIGURE 5. DKP-4016 Keypad

Keypad Button	Shift Function	Dial Function	Description
LOC button	TYPE	1	The LOC/TYP(1) button displays the list of available intercoms (LOCations) available to scroll from. Select an intercom name to access the scroll lists for that intercom. The TYPE button displays the keypanel assignment types available for use.
↑ button	AFK	2	The ↑ (2) button moves you upward through the scroll list or available key assignments one (1) at a time. The AFK (Away From Keypanel) button is used to notify the caller the keypanel user is away from the keypanel. The caller is then able to leave a voice message for the user. For more information, see “Voice Messaging (Audio Package Only)” on page 59. To enable AFK on the keypanel , do the following: <ul style="list-style-type: none"> > Press the SHIFT+AFK(2) buttons. A yellow AFK icon appears on the left of the left panel display. <p>NOTE: For more information, see “Voice Messaging (Audio Package Only)” on page 59.</p>
UPG1 button	UPG2	3	The UPG 1 and UPG 2 buttons are used to assign frequently used menu items. This allows users to access the menu items quickly. UPG buttons can also be programmed to trigger GPI outputs or panel swap events.
← button	←←	4	The ←/←← (4) button moves you backwards through the menu options or available key assignments one at a time or by the page.

Keypad Button	Shift Function	Dial Function	Description
MENU button	INFO	5	<p>The MENU/INFO (5) button is used to access the top level menu structure or access a secondary menu of commonly used features (see, “INFO button” on page 39).</p> <p>The MENU button is used to access the top-level menu structure.</p> <ul style="list-style-type: none"> > Press the MENU button once. <i>The top-level menu appears in the panel display.</i> <p>NOTE: If the keypad backlight is set to Activate (Service Keypad Backlight), you must press the Menu button twice to access the top-level menu. Using the ← (4) and → (6) buttons you can scroll through the list of options available. When a selection is highlighted, Press the SEL button to navigate down one (1) level in the menu structure.</p> <p>To access the INFO menu, do the following</p> <ol style="list-style-type: none"> 1. Press the SHIFT button. 2. Press the MENU/INFO (5) button. <i>The INFO menu appears in the panel display.</i> <p>For more details about the INFO button, see “INFO button” on page 39.</p>
→ button	→→	6	<p>The →/→→ (6) button moves you backwards through the menu options or available key assignments one (1) at a time or by the page.</p>
COPY button	COPY key-to-key	7	<p>The COPY (7) button is used to copy an incoming call key assignment from the CWW to a specific keypad key.</p> <p>For example, if caller THRE calls the keypad, and there is no keypad key assigned, THRE appears in the CWW window in the keypad display. If the keypad operator wants to assign the caller (THRE) a key, use the COPY (7) key on the keypad, and then tap the keypad key where THRE is to be assigned.</p> <p>NOTE: You can also copy from key to key by pressing the COPY+SEL buttons, and then tapping the source key and target key.</p>
↓ button	VM	8	<p>The ↓ (8) button moves you downward through the scroll list or available key assignments one (1) at a time.</p> <p>The VM button is used to retrieve voice messages left on the keypad.</p> <p>To retrieve voice messages, do the following:</p> <ol style="list-style-type: none"> 1. Press the SHIFT+VM(8) buttons. <i>A scroll list of messages appear in the display panel.</i> 2. Using the UP and DOWN arrows, scroll to the voice message you want to listen to. <p>For more information, see “Voice Messaging (Audio Package Only)” on page 59.</p>

Keypad Button	Shift Function	Dial Function	Description
PAGE button	Enters graphical page mode	9	<p>The PAGE button is used to access a different setup page. You can configure up to 15 pages in the intercom system. The default number of pages is four (4). To configure the number of pages available use the Intercom Configuration window, on the Options Page in AZedit.</p> <p>To program a new page directly, do the following:</p> <ul style="list-style-type: none"> > Press the PAGE button, <#>, then tap a key. <p>To enter the graphical page change mode, do the following:</p> <ul style="list-style-type: none"> > Press the PAGE+ SEL buttons. OR Press the SHIFT+PAGE buttons.
CLR button	DROP	*	<p>The CLR/DROP (*) button is used to clear the CWW window or the CLR button functions as a back button.</p> <p>To clear a menu, do the following:</p> <ul style="list-style-type: none"> > Press and hold the CLR button for half a second. <p>If the CLR/DROP button is pressed when in TIF DIAL mode, it hangs up the TIF connection.</p> <p>To access the DROP function, do the following:</p> <ol style="list-style-type: none"> 1. Press the SHIFT button (0), and then the DROP button. <i>Tap Key appears in the panel display.</i> 2. Tap the key you want to drop the call from.
SHIFT button		0	<p>The SHIFT (0) button accesses the secondary keypad actions such as INFO, DROP, etc.</p>
SEL button	DIAL	#	<p>The SEL/DIAL (#) button is used to select options highlighted in the menu structure.</p> <p>Press SHIFT+DIAL and then press the TIF key, to enter TIF Dial mode.</p>
MENU button	UPG 5		<p>The MENU button is used to access the top-level menu structure.</p> <ul style="list-style-type: none"> > Press the MENU button once. <i>The top-level menu appears in the panel display.</i> <p>NOTE: If the keypad backlight is set to Activate (Service Keypad Backlight), you must press the MENU button twice to access the top-level menu.</p>
FWD button	UPG 6		<p>The FWD button moves you forward through the menu option highlighted. For example, if Display is highlighted in the panel display and FWD is pressed, the second level of the display menu appears.</p>
BACK button	UPG 7		<p>The BACK button moves you backward, one (1) level, through the menu structure.</p> <p>NOTE: If you are at the top-level of the menu structure and press BACK, you cannot move backward any further.</p>
UPG 3 button	UPG 8		<p>The UPG 3 button is used to assign a frequently used menu item. This allows users to access the menu item quickly. UPG buttons can also be programmed to trigger GPI outputs or panel swap events.</p>
UPG 4 button	UPG 9		<p>The UPG 4 button is used to assign a frequently used menu item. This allows users to access the menu item quickly. UPG buttons can also be programmed to trigger GPI outputs or panel swap events.</p>

INFO button

The **INFO** button is used to access commonly used features and configuration options for the keypanels. These include the following:

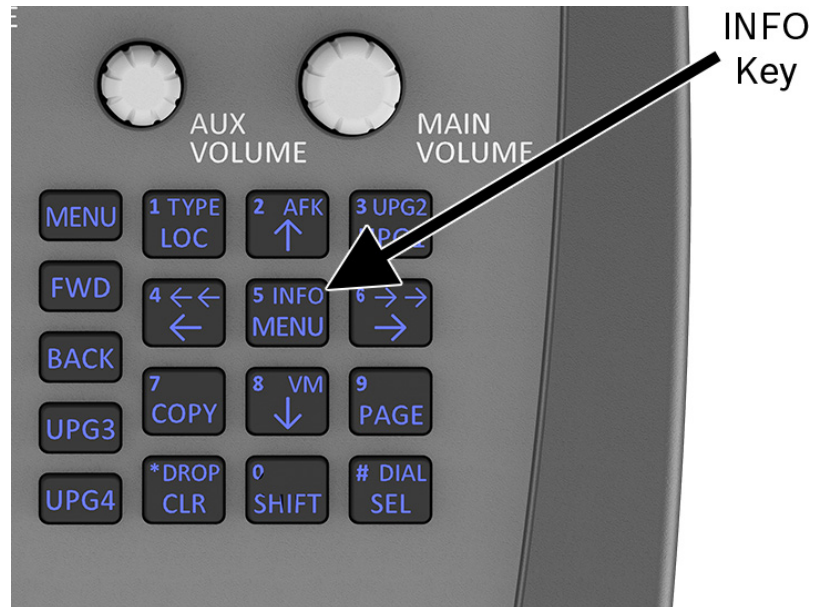

Feature	Description
Panel ID	Displays the port number and alpha of the keypanel.
Level 2	Displays the Level 2 key assignments on the keypanel.
Listen	Displays the listen key assignments on the keypanel.
Callers	Displays a list of current callers to the keypanel.
Assign Types	Displays the assignment types of all the configured keypanel keys.
MAC Address	Displays the MAC Address of the keypanel.
Matrices	Displays the Matrix for each key assignment.
Tone	Opens the Tone Generator menu. For more information, see “Audio Options Menu, Tone Gen” on page 201.
Setup Pages	Displays the setup pages assigned to each row of keys. You cannot change setup pages from this menu.
Reset Vols	Opens the Key Volumes Reset menu. For more information, see “Audio Options Menu, Key Volumes” on page 196.
Hidden Asgns	Displays key assignments assigned to virtual keys (ie, assignments not currently visible).
Test Panel	Enables the Test Panel feature. For more information, see “Service Menu, Test Panel” on page 242.
Version	Displays the firmware version of the DKP-4016/4016W. For more information, see “Display Menu, Version” on page 207.

To **access the Info Menu**, do the following:

1. On the keypad, press the **SHIFT** button.
2. On the keypad, press the **INFO MENU (5)** button.
The INFO menu appears in the panel display.

NOTE: To exit the INFO menu mode, press the **CLR** button.

Breadcrumb Menu Navigation

Breadcrumb Navigation is a graphical aid to help users know where they are in the menu structure. The breadcrumb menu visually lays out a path of options selected up to the current menu position. It appears as a horizontal line above the menu options. (shown in Figure 6).

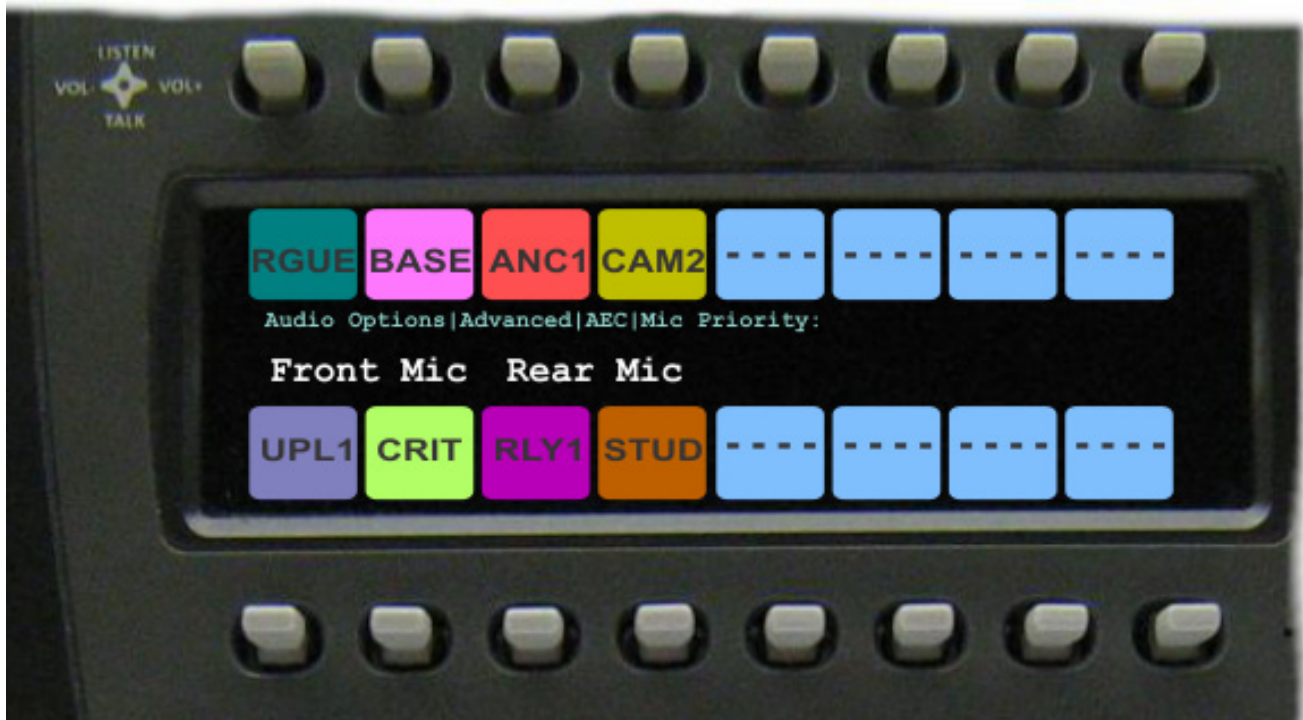

FIGURE 6. Breadcrumb Navigation

Menu Navigation and Shaft Encoder Knobs

While the keypanel is in menu mode, the **AUX Volume** shaft encoder is used to move the selection left and right. Or in the case of a single menu item with up and down control, the shaft encoder is rotated to scroll through the available selections. This is particularly convenient when setting the keypanel brightness or gain. Also, pressing the Aux Volume shaft encoder while in menu mode is the equivalent to SEL key operation. Conversely, pressing the **MAIN Volume** shaft encoder in menu mode is the equivalent to the CLR key operation. Double-tapping the AUX Volume shaft encoder, can also be used for the CLR operation.

Other navigation options:

- Press and hold the **AUX/MENU shaft encoder** to exit the menu.

CLR Button

The **CLR** button is used either as the **BACK** function while in **MENU** mode or to exit **MENU** mode completely.

To **go back one menu level**, do the following:

- > Press the **CLR** button **once**.

To **exit the menu**, do the following:

- > Press and hold the **CLR** button **for half a second**.
- OR
- Press the **CWW** key **up**.

Basic Intercom Key Operation

Figure 7 displays the different key positions and their meanings.

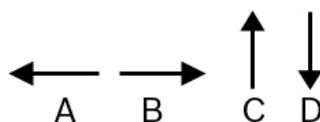

- A= Decrease Listen Volume
- B= Increase Listen Volume
- C= Listen
- D= Talk

FIGURE 7. Key Function Position Explanation

To **talk on the keypanel**, do the following:

- > Press **down** on the keypanel key you want to use.

To **listen on the keypanel**, do the following:

- > Press **up** on the keypanel key you want to use.

Talk/Listen Indicator

The **Talk/Listen Indicator**, shown in Figure 8, displays a visual indicator when the talk and/or listen key is active. The talk and listen states of each key are represented by an LED-like horizontal bar at the bottom (talk) and top (listen) of each key.

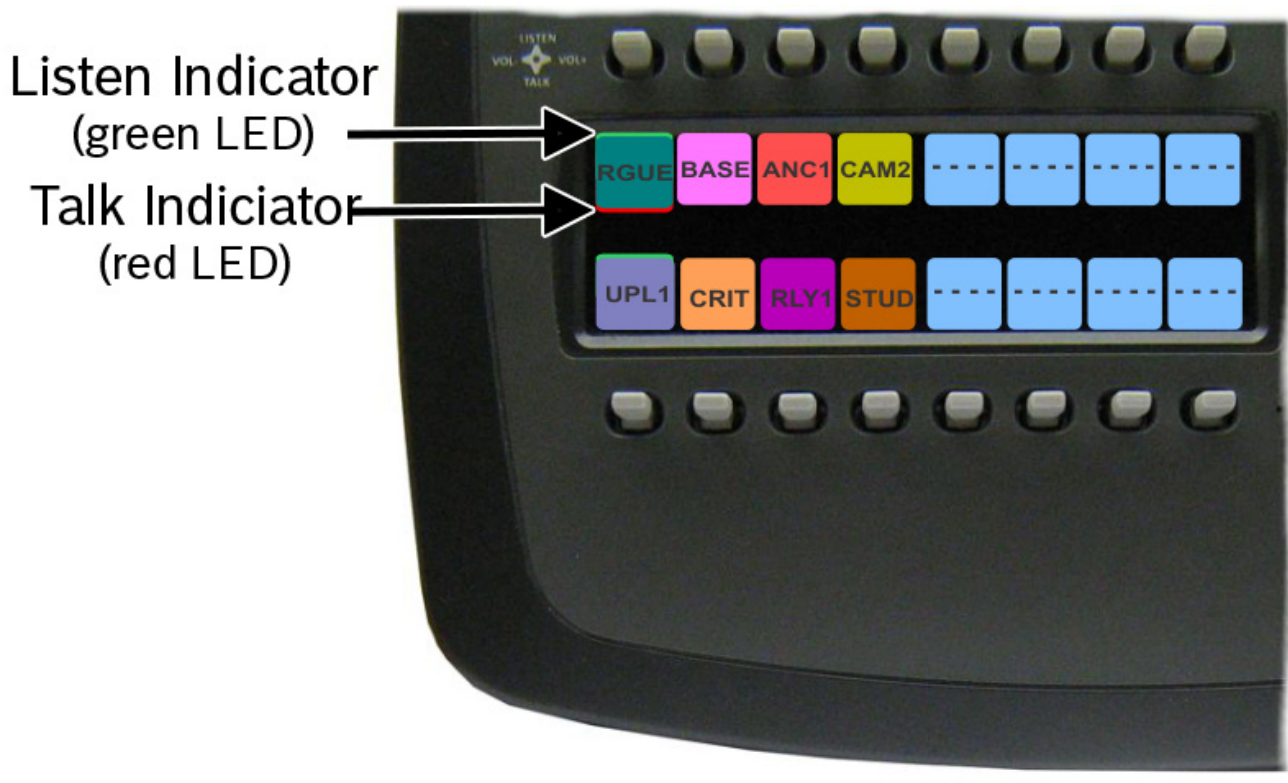

FIGURE 8. Talk/Listen Indicators

By default, the listen indicator is green and the talk indicator is red. You can change the colors of the indicator by using the Key Color Window in AZedit. For more information, see “Keypanel Color Window” on page 66.

Key Gain Adjustment

The **Key Gain Adjustment** is used to change the crosspoint listen gain on a specific key from the Matrix. This adjustment is automatically reflected in AZedit on the Crosspoint Gains window. (System|Gains|Crosspoint).

The range for this feature is *+6dB to -80dB, Mute*.

NOTE: Key gain can only be adjusted when the listen function listens to a PP, PL, or, an IFB with an Auto-Talk function on the listen key and a Listen Source programmed for the IFB.

To **adjust the crosspoint gain using the keypad key**, do the following:

- > On the DKP-4016/4016W front panel
 - Press the **keypanel key** to the right to increase the listen gain for the selected key assignment.
 - Press the **keypanel key** to the left to decrease the listen gain for the selected key assignment.
A volume status bar () and the volume level, in dB, appear on the specified key in the panel display.

To **adjust the crosspoint gain using the AUX Volume encoder shaft**, do the following:

1. Lift and hold the **keypanel key** for which you want to adjust the crosspoint gain.
2. Turn the **AUX Volume encoder shaft to the right to increase the gain.**
OR
Turn the **AUX Volume encoder shaft to the left to decrease the gain.**

NOTE: The volume bar shows a full width icon, but only colors the portion that represents volume. The remainder is of the bar is shown in black. This is so when the key gains are always displayed, the user will know when a key is muted, as opposed to a key that cannot have gain adjusted.

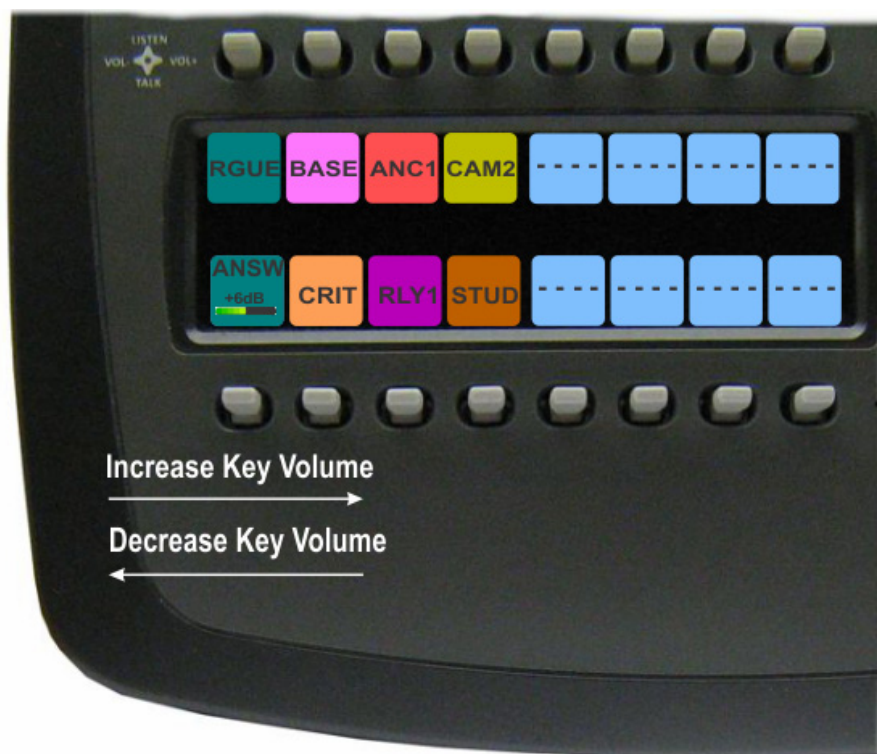

Keypanel Volume Adjustments

By default, the main volume control adjusts the Output Volume for the speaker (front/rear) or headset (left/right), whichever is currently active.

Output volume ranges from +10dB to -48dB and Mute.

NOTE: If you gang speakers and/or headset volumes, you see a split volume bar. The front speaker or left headset is the top portion of the bar, while the bottom portion of the bar is the rear speaker or right headset volume. For more information on Gang Volumes, see “Audio Options Menu, Ganged Vols” on page 192.

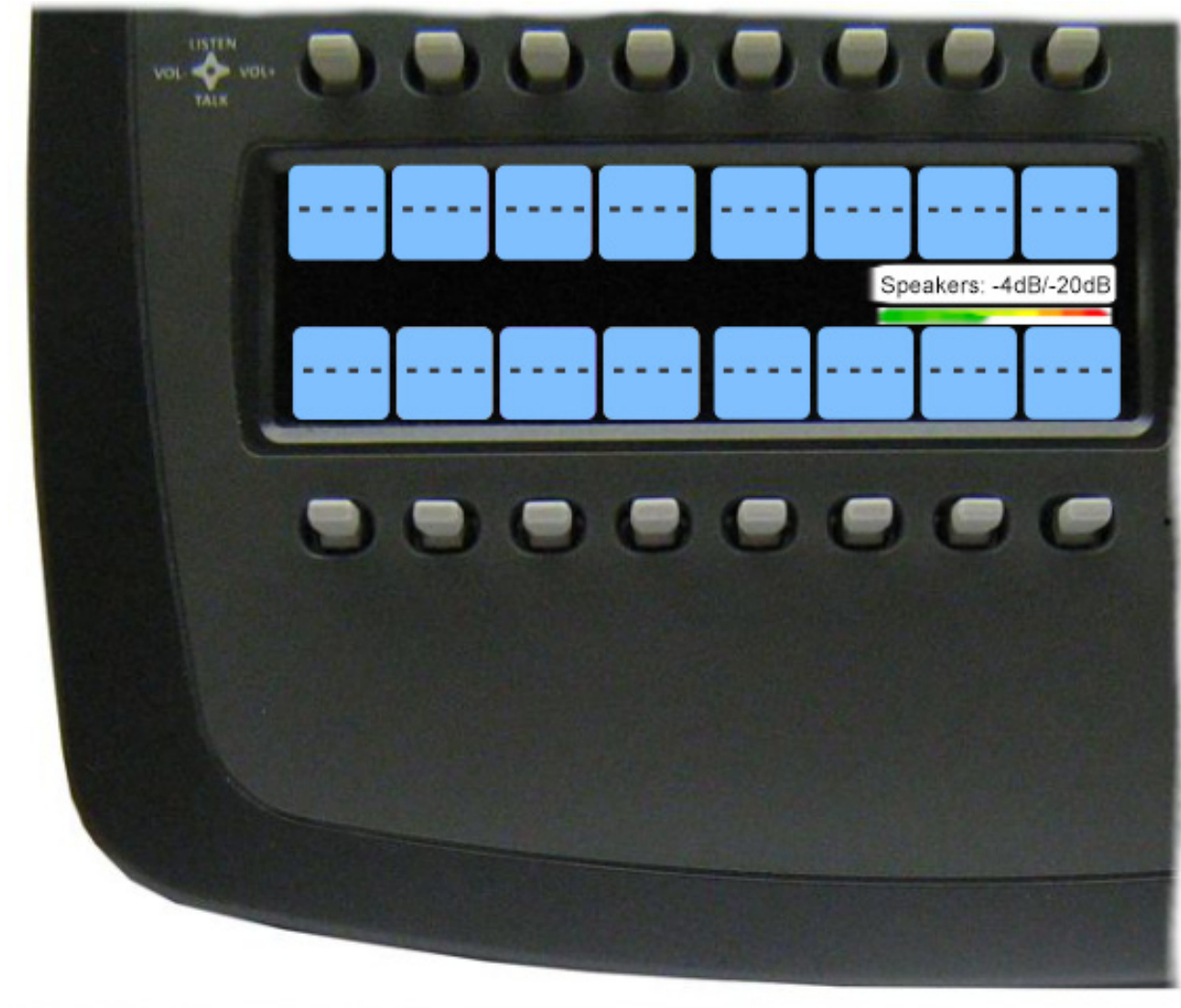

To **adjust output volume level**, do the following:

- > On the DKP-4016/4016W, turn the **MAIN VOLUME encoder** to the right to increase the volume for the selected output. OR
Turn the **MAIN VOLUME encoder** to the left to decrease the volume for the selected output.

NOTE: When the MAIN VOLUME encoder is turned, the volume level bar appears in the panel display.

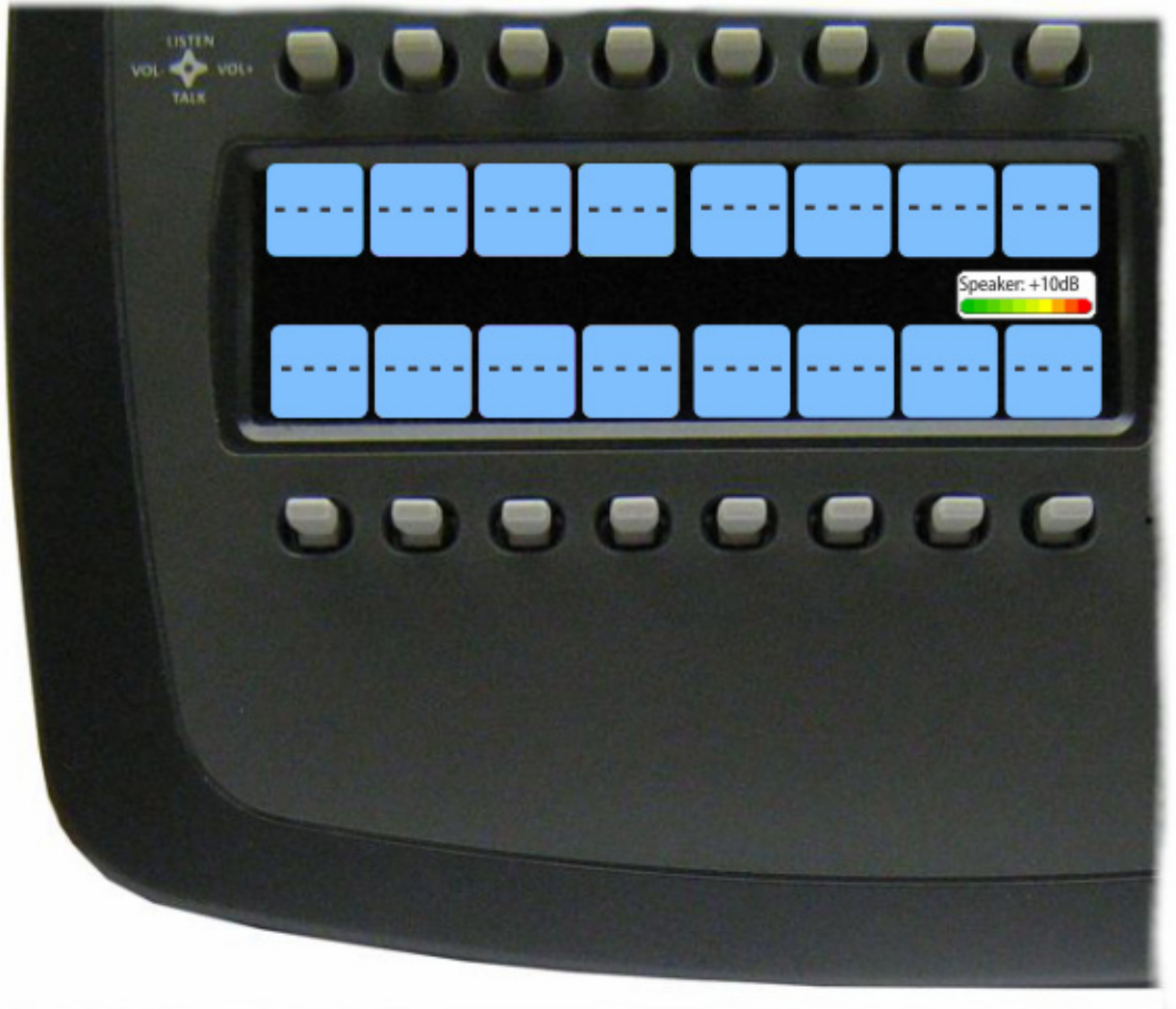

NOTE: You can save the volume adjustments to be power-up defaults using “Menu System, Save Config” on page 223.

To select a different output volume control, do the following:

- > On the DKP-4016/4016W, push the **MAIN VOLUME** encoder once.
The main volume focus switches to the next available output.

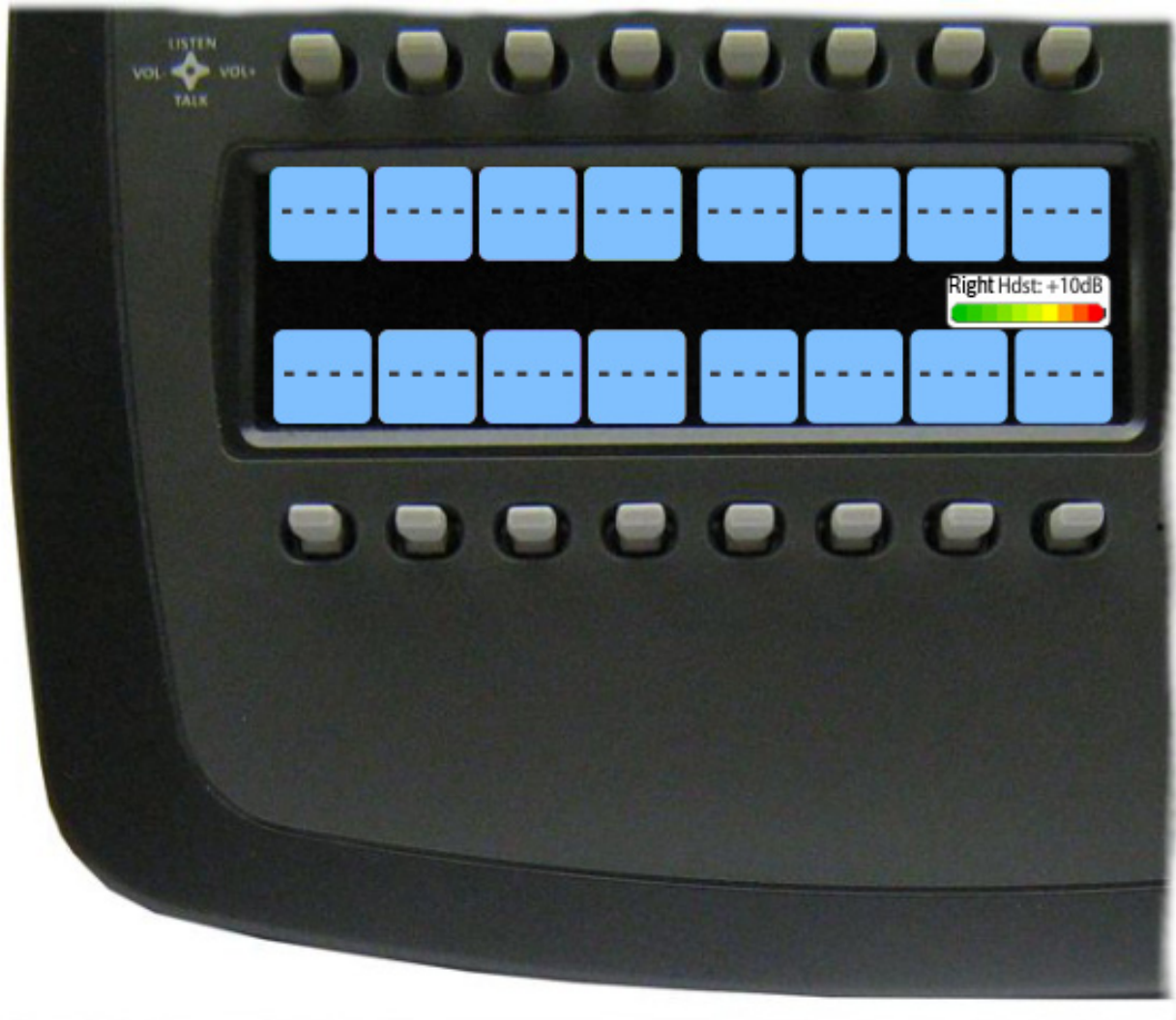

Aux Volume Adjustments

By default, the **Aux Volume** control knob adjusts the selected input volume, which can include Aux, Matrix Input, or OMNEO 1-8, depending on licensing and whether the connection is via OMNEO or AIO.

Input volume ranges from +10dB to -48dB and Mute.

To **adjust listen volume level**, do the following:

- > On the DKP-4016/4016W, turn the **AUX VOLUME encoder** to the right to increase the volume for the selected input.
OR
Turn the **AUX VOLUME encoder** to the left to decrease the volume for the selected input.

NOTE: When the AUX VOLUME encoder is turned, the volume level bar appears in the panel display.

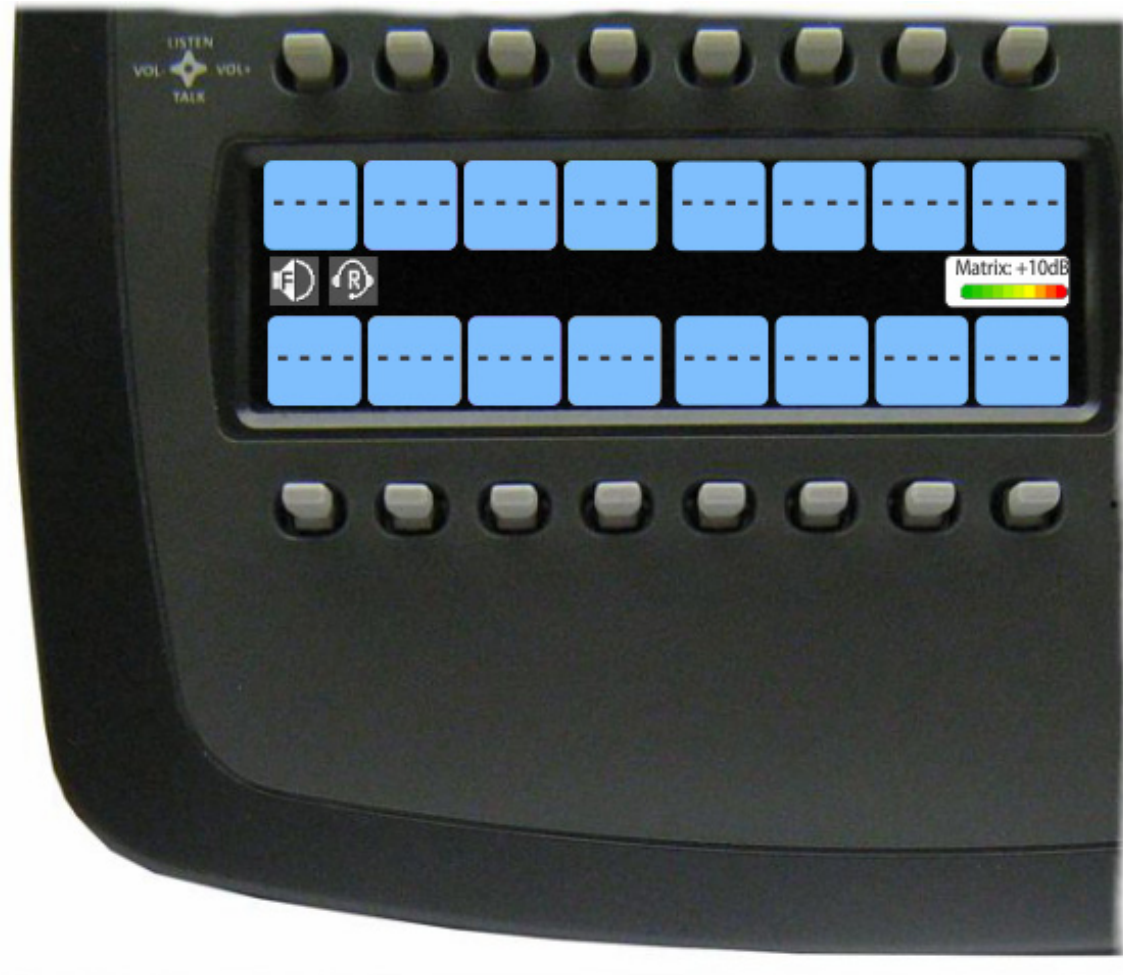

NOTE:

- You can save the volume adjustments to be power-up defaults using “Menu System, Save Config” on page 223.
- The inputs are available if they are enabled and mixed to an output.

To **change the focus of the volume control**, do the following:

- > On the DKP-4016/4016W, push the **AUX VOLUME encoder** once.
The aux volume focus switches to the next available input.

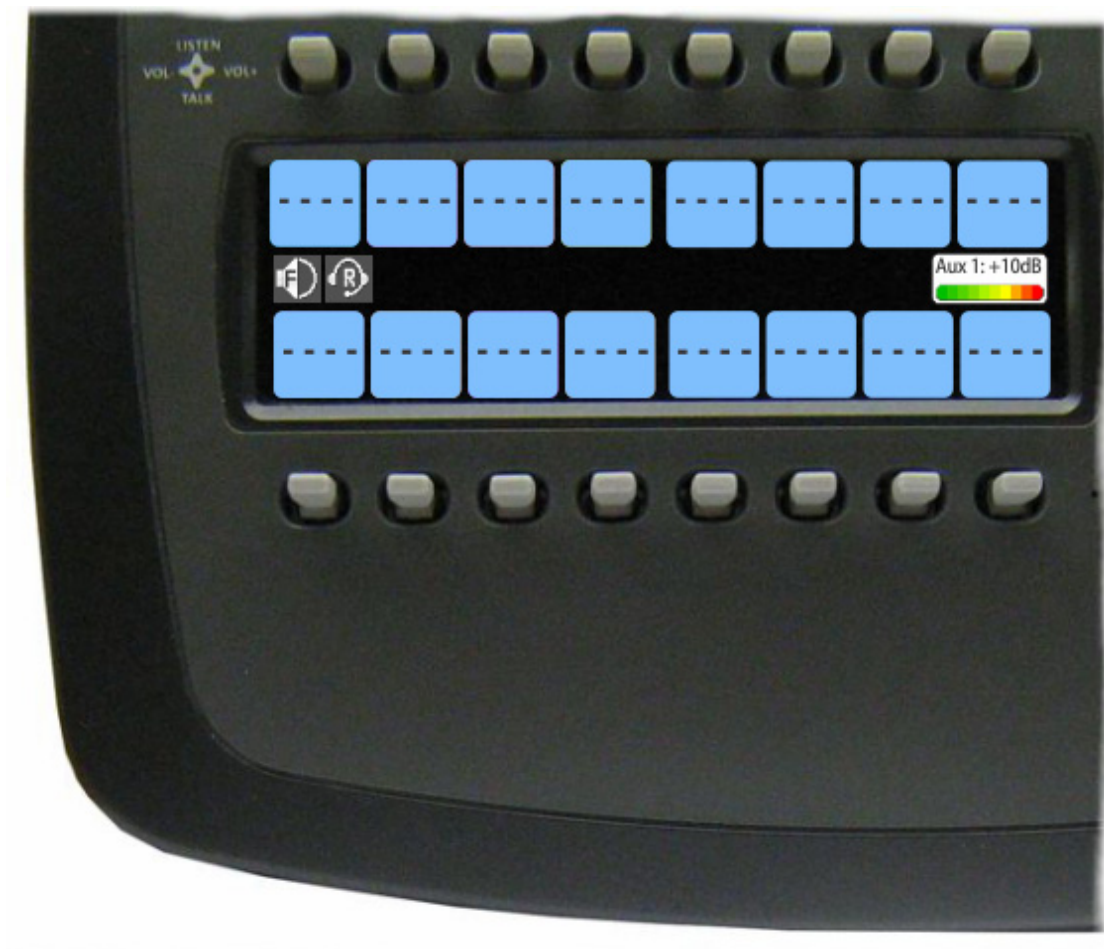

Priority Call Volume Control

Priority Call Volume Control is used to mark a keypanel as a priority caller. When a priority caller talks to another keypanel, a minimum crosspoint volume (configurable in AZedit) is enforced for the duration of the call to ensure the caller is heard, even if the target panel has set the listen volume to a lower volume.

In addition, a minimum volume of -6dB on the speaker and headset of the target panel is also enforced when receiving a call from a priority caller (also ensuring the caller is heard, even when the target panel's headset and speaker volume is turned down. Once the call is completed, the previous speaker, headset, and crosspoint volumes are restored when the priority caller stops calling.

When a panel is the target of a priority call, the speaker, headset, and volume display are shown with an orange background indicating a priority call is in progress.

NOTE: The volumes are never lowered by the priority call, but are raised to the minimum values for the duration of the call if they had lower values to begin with.

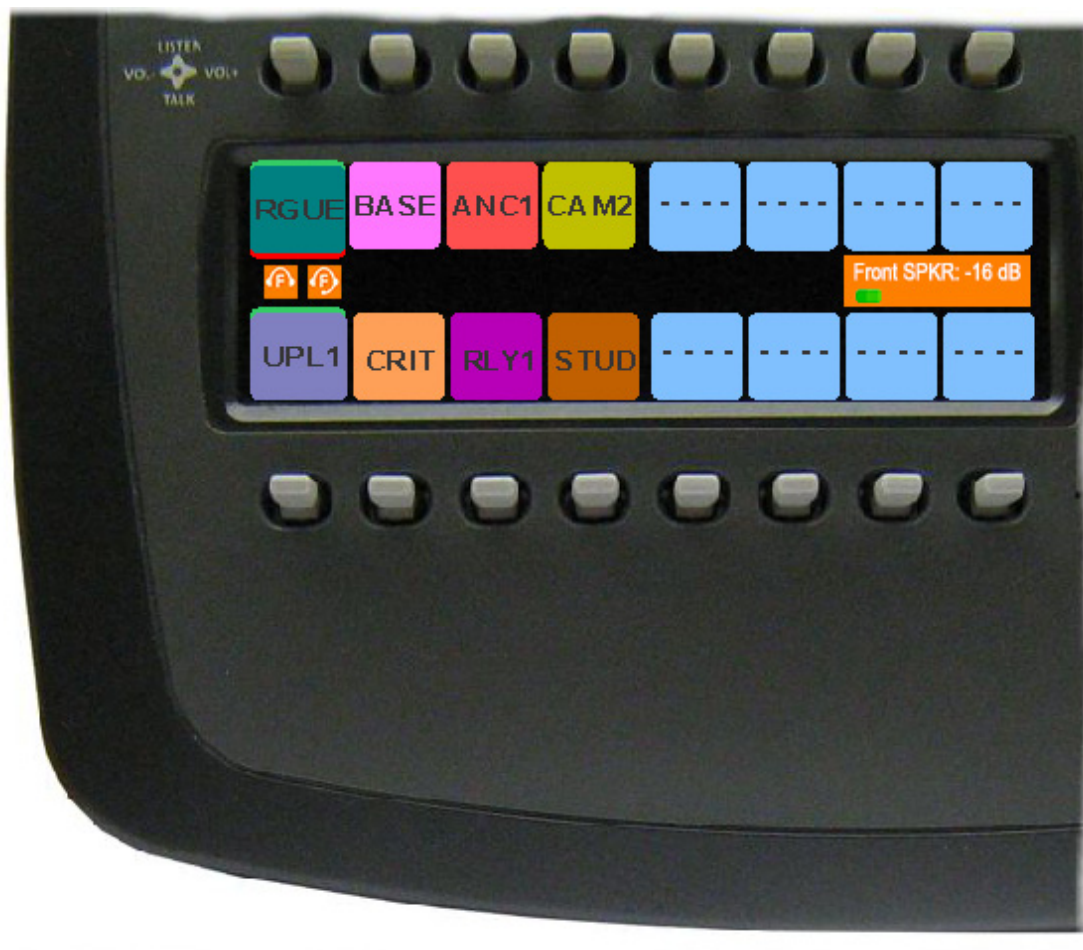

FIGURE 9. Incoming Priority Call Volume Control Keypanel

Available crosspoint values range from: +6dB, -80.0dB, and Mute.

By default, the priority call volume is set to +0.0dB.

To **configure priority call volume control**, do the following:

1. On the Keypans/Ports screen in AZedit, select the **port** you want to set with priority call volume control.
2. Click the **Edit button**.

The Keypanel/Port Configuration screen appears.

The screenshot shows the 'Keypanel / Port Configuration' dialog box with the 'Advanced' tab selected. The 'Priorities' section contains three input fields, all set to '1': 'IFB Priority', 'Trunk IFB Priority', and 'Trunk Priority'. Below this is the 'Panel Poll Delay (ms)' section with a text box containing '0' and a 'Reset' button. The 'IFB Listen Destination' section has two dropdown menus: 'Port Number' and 'Port Alpha', both set to '4'. The 'Options' section contains several checkboxes: 'Enable Tone', 'Keypanel Privacy', 'TIF Dial-Out Restrict', 'Key Labels', 'Do Not Interrupt', 'Priority Call Volume' (checked), and 'Enable Keypanel Mirroring'. The 'Priority Call Volume' dropdown is set to '+0.0 dB'. At the bottom of the dialog are buttons for 'OK', 'Cancel', 'Apply', and 'Help'.

3. Click the **Advanced tab**.
The Advanced Page appears.
4. Select the **Priority Call Volume check box**.
5. From the Priority Call Volume drop down box, select the **crosspoint volume level** for the priority caller.
6. Click the **Apply button**.
7. Send the **change to the Intercom**.

Operation of Intercom Keys with Auto Functions

NOTE: Assignment of keys with auto functions is described in the programming section that follows.

Operation of keys with auto functions, is as follows:

<i>Talk+auto follow</i>	Talk and listen can be activated separately. The listen assignment listens to whatever is assigned to the talk key.
<i>Talk+auto listen</i>	Both talk and listen activate when talk is activated.
<i>Talk+auto mute</i>	Listen turns off when talk is activated.
<i>Talk+auto reciprocal</i>	Listen is always on and talk may be turned on or off.
<i>Talk+auto table</i>	If an IFB talk key has an auto table listen assignment, talk and listen is independently activated. The listen key listens to whatever is defined as the IFB Listen Source for the IFB assigned to the talk key.
<i>All Call</i>	Activating this key activates all keys to the left of it, up to, but not including another all call key.
<i>Talk+DIM</i>	If a point-to-point key has the DIM function as a level 2 talk assignment, activating the key causes the crosspoint levels to diminish for any other intercom ports currently listening to the same destination and are in the same DIM tables.

Operation of Intercom Keys with Options

Group Option Keys

Activating the master key in a key group activates all keys in the group according to each key's individual key assignment. Activating a slave key does not affect any other keys in the group. For more information, see "Key Options Menu, Key Groups" on page 217.

Solo Key

Activating a key with the solo option causes all other keys to turn off until the solo key is turned off. For more information, see "Key Options Menu, Solo" on page 220.

Exclusive Key

Activating a key with the exclusive options causes all other Exclusive keys to turn off when activated. Unlike the solo option, when exclusive is deactivated, the keys turn off and stay off. For more information, see "Key Options Menu, Exclusive" on page 215.

Lock Key

A key with the lock option on it is locked in the on or off position and cannot be changed until the lock is removed. For more information, see "Key Options Menu, Lock (Button Lock)" on page 218.

Chime Key

When a chime is configured on a key and a call is received, the chime is activated. You can configure length and type of chime for the key, as well. For more information, see "Key Options Menu, Chime" on page 214.

Clear Keys

Clearing keys is used to remove any key options assigned to a specific key or UPG button assignment. For more information, see "Key Options Menu, Clear" on page 214.

Latching Keys

Latching keys on a keypanel gives the user hands-free operation where keys stay active after quickly tapping the key. For more information, see "Key Options Menu, Latching" on page 217.

Operation of Intercom Talk Keys with the Speaker DIM Setting

Activating any talk key causes the speaker or headphone volume at the keypanel to diminish by the amount specified in the DIM menu item on the Service menu. For more information, see "Audio Options Menu, Dim" on page 191.

NOTE: Do not confuse this with the Talk+DIM auto function previously described. Talk+DIM affects the speaker or headphones on other keypanels when a particular talk key is activated on the keypanel. Speaker DIM affects the speaker or headphone level on the keypanel when any talk key on the keypanel is activated.

Operation of Intercom Keys assigned to TIF Ports

If a keypanel key is assigned to talk to an intercom port designated as a TIF port in AZedit, placing the key in the talk position activates the DKP-4016/4016W dialing menu. For more information, see “Telephone Interface (TIF) Operation” on page 245.

To **designate an intercom port as a TIF port**, do the following:

1. In AZedit, select the **port** you want to designate as a TIF port on the Keypanel/Port window.
2. Click the **Edit button**.
3. On the Advanced tab, select the **Port is TIF check box**.
4. Send the **change** to the intercom system.

User Quick Select Scrolling

User Quick Select Scrolling is a fast and easy way to call or assign a point-to-point key on the DKP-4016/4016W.

To **use the User Quick Select Scroll feature to call a user**, do the following:

1. On the DKP-4016/4016W keypad, press the **left and right arrow buttons** to scroll through the list of point-to-point connections available.
The selected port is highlighted in white.

NOTE:

- You can also use the left and right arrow buttons to page scroll through the list of ports available. Page scroll is useful when you have a large intercom system and you want to find a port quickly.
- You can also use the AUX Shaft encoder to quickly scroll through the list once you are in the scroll list menu.

To **page scroll**, do the following:

1. Press the **SHIFT button** before pressing the **left or right arrow buttons**.
OR
Press the **SHIFT button** and then press and hold the **arrow button** to repeat scrolling a page at a time.
Remember, when you let go of the key, it exits SHIFT mode.
2. When the port is selected, press down on the **CWW key** to talk to the selected port.

Graphical Call Waiting Window

Traditionally, incoming calls have been displayed on key 16 on the keypad, flashing to indicate an incoming call. The DKP-4016/4016W Series keypad can keep a history of the last nine (9) callers and display them in a scrollable, graphical window above keys 15 and 16. The CWW displays three (3) calls at a time (only two (2) in Kanji) with a scroll arrow appearing if there are more than three (3) calls in the list.

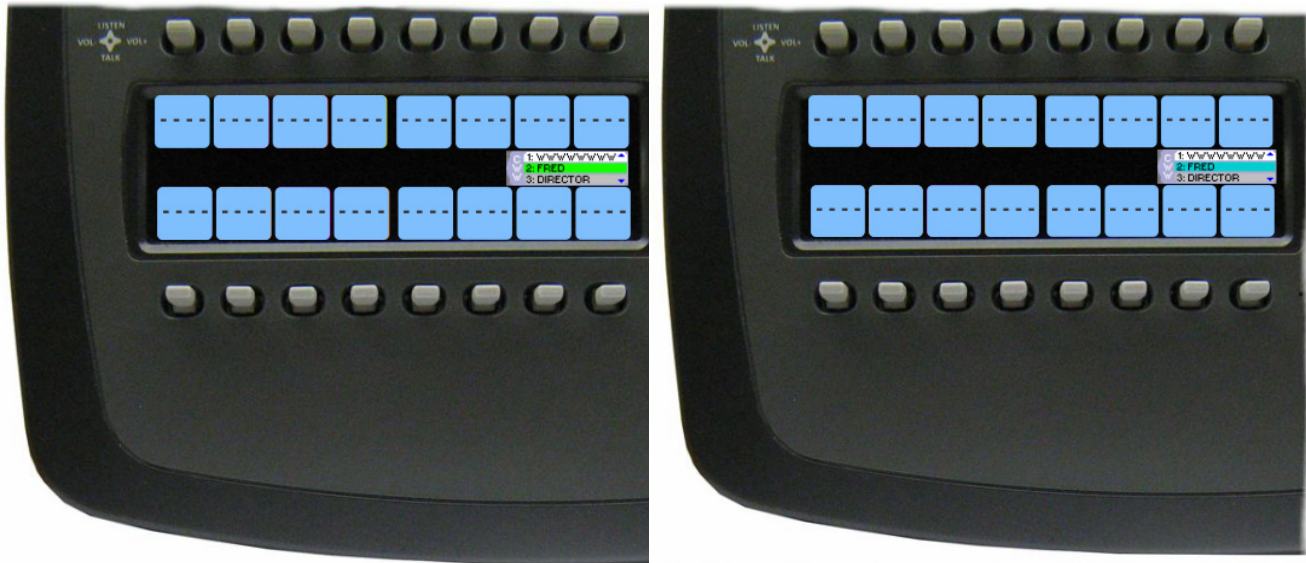

FIGURE 10. Graphical Call Waiting Window

TABLE 4. Graphical CWW Call Description

Item	Description
New Call	White background
Selected Call / Not Talking	Cyan background
Selected Call / Talking	Green background
Old Call	Gray background

Graphical Call Waiting Window Operation

Use Table 4 on page 54 and Figure 10 on page 54 to understand the different states of the CWW.

Display or Hide the CWW

To **display the CWW**, do the following:

- > On the DKP-4016/4016W panel, lift up on the **CWW** key.
The graphical call waiting window appears.

To **hide the CWW**, do the following:

- > Press the **CLR** button.
The CWW closes.

NOTE: If the CWW list is visible and not empty, it remains visible until hidden. If the CWW list is visible, but empty, it auto-hides after a five-second timeout.

Incoming Calls

When a call is received at the DKP-4016/4016W panel, the graphical CWW list appears on the keypad display. Unlike the keypad tally indicators in previous keypad versions:

- the graphical CWW list appears on the keypad display.
- the graphical CWW and the call flashes (tallies), rather than the CWW button.

A minimum of three (3) calls, up to a maximum of nine (9) calls can be configured to be stored in the CWW history scroll list. The most recent call is inserted at the top of the graphical CWW list (position 1) with a white background (See Figure 10 on page 54). Other items in the CWW list are shifted down, as necessary. When a new call is received, the last call in the list is dropped, unless it is highlighted in the graphical CWW. In this case, it cannot be shifted off the CWW list..

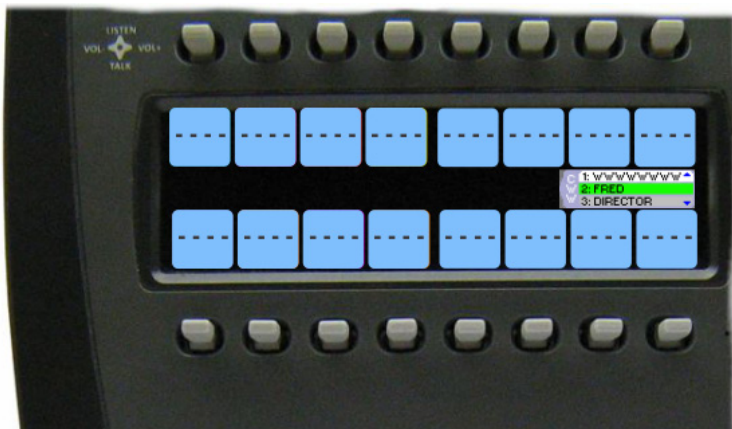

DKP-4016

FIGURE 11. Graphical Call Waiting Window Highlighted Call

NOTE: For more information on the CWW mode options, see “Service Menu, CWW” on page 225.

To **scroll the CWW list**, do the following:

- > When the CWW list is visible, press the **arrow up button** or the **arrow down button**.
The highlight moves through the scroll list.

To **answer a call on the graphical CWW**, do the following:

1. Scroll the **CWW** to highlight the call you want to answer.
The highlighted call is shown with a cyan background.
2. Press and hold the **CWW key** to talk to the caller.
The highlight in the CWW list turns green and moves to the top of the list when talking with the caller.
3. Release the **CWW key** to stop talking.
The call is ended. The background of the caller in the CWW list turns a light gray (if not highlighted).

Clearing the CWW List

To **clear the CWW list**, do the following:

1. If the CWW is not visible, press the **CWW key** to make it visible and the call selected.
2. Use the **up and down arrows** to select the call to remove.
3. Press the **CWW key up**, to clear the selected entry.
4. Repeat **steps 2 & 3**, as necessary.

Mute the Microphone/Speaker

When the Mic Mute switch is pressed up, the corresponding microphone(s) are muted. The Mic Mute switch can be disabled or configured to operate in either Toggle or Momentary mode.

For more on Mic Mute Modes, see “Audio Options Menu, Mic Mute” on page 198.

For Mic Mute key location, see “Reference View – DKP-4016/4016W” on page 15.

Mic Select

Every mic (input) or speaker/headset (output) can be configured as Always On or Enabled, Disabled, or Switched. Only mics, speakers, or headsets set to Switched are controlled by the MIC SEL key.

For more information, see:

- “Audio Options Menu, Headset Speaker” on page 194.
- “Audio Options Menu, Panel Mic” on page 199.
- “Audio Options Menu, Headset Mic” on page 192.

TABLE 5. Source Configuration Matrix and Display icons





























	ALWAYS ON/ENABLED	SWITCHED	DISABLED	ICON DISPLAYED
Panel Mic				
	Front and Rear			
	Front	Rear		 OR 
	Rear	Front		 OR 
	Front		Rear	
	Rear		Front	
			Front and Rear	No icons display on the keypad.
Headset Mic				
	Left and Right			
	Left	Right		 OR 
	Right	Left		 OR 
	Left		Right	
	Right		Left	
			Left and Right	No icons display on the keypad.

TABLE 5. Source Configuration Matrix and Display icons

	ALWAYS ON/ENABLED	SWITCHED	DISABLED	ICON DISPLAYED
Speaker				
	Front and Rear			
	Front	Rear		 OR 
	Rear	Front		 OR 
	Front		Rear	
	Rear		Front	
			Front and Rear	No icons display on the keypanel.
Headset				
	Left and Right			
	Left	Right		 OR 
	Right	Left		 OR 
	Left		Right	
	Right		Left	
			Left and Right	No icons display on the keypanel.

Setup Pages

Setup Pages are used to allow access to more key assignments than there are physical keys on the keypad. This is useful for sharing a keypad because you can use setup pages to swap between the key assignments used for each person. An alternative to Setup Pages is Panel Swap (see, “Key Options Menu, Panel Swap” on page 218). Note, with Panel Swap, your system must be configured for more keys per panel, whereas with Setup Pages, you do not need to increase the number of keys per panel, but can simply assign different setup pages to each row of keys.

You can have up to 15 setup pages per keypad port.

NOTE: To change the Setup Pages available for ports, in AZedit go to Options|Intercom Configuration|Options tab. Change the Setup Pages per port field to the number of pages needed.

By default, eight (8) pages are available.

IMPORTANT: To add key assignments to the setup pages, see “Menu System, Key Assign Menu” on page 208.

To **open and assign setup pages**, do the following:

1. Press the **PAGE** key.
The Page menu appears in the display screen.
2. Press **SEL** to get to the graphical mode
OR
Enter a **digit (page number)**.
3. Tap a **key** to assign that page to the key row.

To **toggle between setup pages**, do the following:

1. Using the left and right arrows, change the **page on the current key row**.
2. Press the **SEL** key (or just wait 2 seconds to auto-select).

To **change the highlighted key row in the graphical mode**, do the following:

- > Using the FWD/BACK or UP/DOWN keys, change the **highlighted key row**.
OR
Press the **SHIFT + LEFT** buttons or the **SHIFT + RIGHT** buttons to change the highlighted key row.

Menu Passwords

As with other keypanels, the DKP-4016/4016W allows you to lock the entire menu structure or only the service menu. This is implemented through AZedit (System|Miscellaneous|Keypanel Menu Password. For more information, see the AZedit user manual (p/n F01U239453).

NOTE: Only numerical passwords are allowed.

To enter a menu password at the password prompt, do the following:

1. Press the **MENU button**.
? appears in the keypanel display screen.
2. Using the keypad, enter the **password** for the menu.
3. Press the **SEL key**.
When the password is completely entered correctly, the menu appears.

NOTE:

- Use the CLR button, double-click the AUX shaft encoder, or single-click the MAIN shaft encoder to erase the last digit.
- If there are no digits, the CLR button or double-clicking either the AUX shaft encoder or MAIN shaft encoder exits the menu.

Voice Messaging (Audio Package Only)

IMPORTANT: If you are upgrading your DKP-4016 from v1.1.1 or earlier to version 1.2.0 or later, you must do the following:

- Download the Firmware
- Download the License, if purchased
- Download the Voice Mail Chimes (downloaded with vm-chimes.mot)
- Download the Voice Mail Icons (downloaded with vm-icons.mot)

For information on downloading firmware, see “Download Firmware to the DKP-4016/4016W From AZedit” on page 151.

Take note, the VM chimes and VM icons are .mot files and should be treated as firmware downloads, not Chimes or Icons.

Panels shipped from the factory with v1.2.0 or higher, include vm chimes and vm icons.

VM (Voice Messaging) allows a caller to leave an audio message at a keypanel where the keypanel user has stepped away from or is currently busy and cannot answer a call.

There are two (2) modes of voice messaging; *AFK* and *Auto-Record*.













AFK (Away From Keypanel) mode indicates the keypanel user is not available or is away from the keypanel. AFK enables callers to leave a message for the user to listen to upon return to their keypanel.

Auto-Record mode indicates the last 30 seconds of audio is always being recorded. When Auto-Record is active it does not matter if AFK is enabled or not, the keypanel constantly records the last 30 seconds of audio. On the keypanel in which Auto-Record is enabled, the record icon appears in the keypanel display window (see “Voice Messaging Icons” on page 60). Unlike AFK, where the recording icon is flashing while a message is being recorded, the icon is constant.

To configure how you want voice messaging to work, see “Audio Options Menu, VM Options (Audio Package Only)” on page 202

Up to seven (7) voice messages can be recorded, with each voice messages being up to 30 seconds long.

Voice Messaging Icons

Icon	Description	Operation
	AFK (Away From Keypanel)	This icon appears in the keypanel display when the keypanel is put into AFK mode.
	Keypanel in AFK Mode	This icon appears on the callers key when the keypanel being called is in AFK mode. The caller receives a flashing dialog balloon and a chime, alerting them to the AFK status of the keypanel they are trying to call. The caller can then choose to leave a message on that keypanel.
	Record in AFK Mode	This icon appears on the callers key when a message is being left at another keypanel that is in AFK mode, the record icon appears to let the user know they are recording a message.
	Auto-Record	This icon appears in the keypanel display when the keypanel is in AFK mode and someone is leaving a message or Auto-Record is set to Rolling Buffer. This means the keypanel is constantly recording the last 30 seconds of audio, regardless of the keypanel state. This icon also appears flashing on a keypanel that is AFK and receiving a message.
	Stop	The stop icon appears on the callers key when the VM recording is ended.
	Play/Pause	This icon appears in the VM menu and is used to start playing a voice message.
	Fast Forward	This icon appears in the VM menu and is used to fast forward through a voice message.
	Rewind	This icon appears in the VM menu and is used to rewind through a voice message.
	Voice Message	This icon appears in the keypanel display when a voice message is left on the keypanel. The red circle in the lower right corner of the icon shows how many messages have been left. Up to seven (7) messages can be stored at a given time.
NOTE: The following icons appear on the panel trying to leave a message.		
	Target is not present	This icon appears when you try to leave a VM for a panel that is not connected.
	Target is not AFK	This icon appears when a user tries to leave a voice message when the keypanel is not in AFK mode. The red X blinks on the yellow background for five (5) seconds.
	Target is busy	This icon appears when the keypanel being called is busy, such as already recording a message, there is no recording room left, or the user is in the VM menu.

To **toggle on AFK mode**, do the following:

- > On the keypanel keypad, press **SHIFT+AFK**.
The AFK icon appears in the panel display.



To **toggle off AFK mode**, do the following:

- > On the keypanel keypad, press **SHIFT+AFK**.
The keypanel deactivates AFK mode.

To **leave a message**, do the following:

1. On the keypanel, press the **key assigned to the keypanel you want to call**.
If AFK is activated, a flashing dialog balloon icon appears and a chime sounds alerting you of the AFK status.
2. On the keypad, press the **Shift key and the keypanel key you are trying to contact**.
A flashing red dot on a white background (record) icon appears and a chime sounds. The recording begins. A countdown time appears on the key, advising of the time left to record.
3. Leave a **message for the keypanel user** you are trying to contact.

NOTE: Messages are limited to 30 seconds.

4. When you are finished leaving a message, release the **keypanel key**.
The message is complete. A black square with a white background (stop recording) icon appears and a chime is heard. This icon disappears after three (3) seconds.

NOTE:

- A cassette tape icon appears on the keypanel where the message was left, alerting the user of the voice message.

Voice Messages Menu

The **Voice Messages** menu is used to display, retrieve, and listen to voice messages. When a keypanel receives and stores a VM or the keypanel has Rolling Buffer enabled, the voice message menu is accessible. From the Voice Message menu you can scroll through a list of available messages – most recent first – showing the caller, the duration of the message and how long ago it was left. See figure Figure 13.

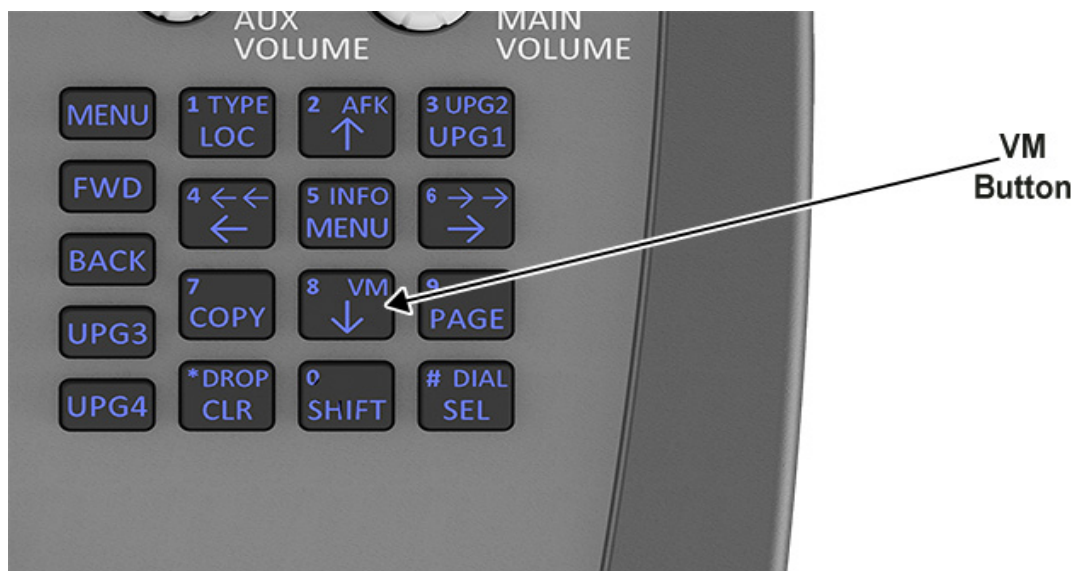

FIGURE 12. VM Button

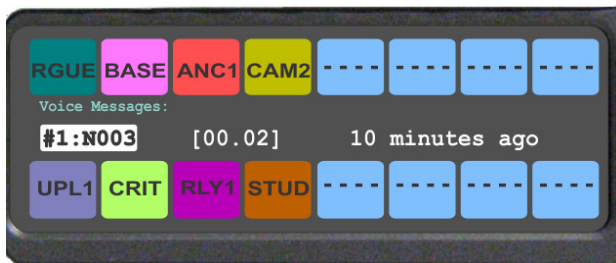

FIGURE 13. Voice Message Menu

To enter the Voice Messages menu, do the following:

1. On the keypad, press the **SHIFT+VM/8** buttons.
A scroll list of voice messages appear in the keypad display window.
2. Using the up and down arrow keys, scroll to the **desired voice message**.
OR
Using the AUX VOL shaft encoder, scroll to the **desired voice message**.

VM Playback Menu

The **VM Playback** menu is used to play and listen to voice messages you receive on the keypad.

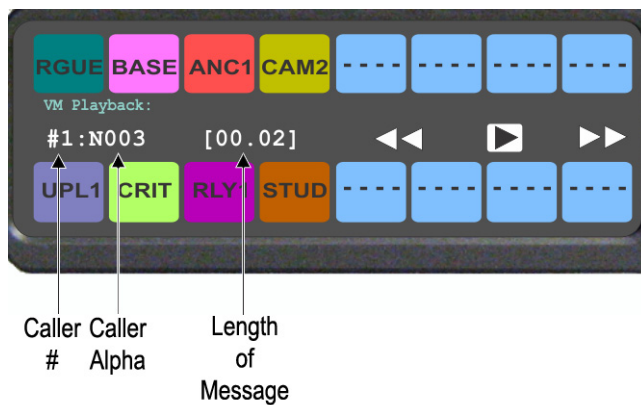

FIGURE 14. VM Playback Menu

To listen to a message, do the following:

1. Using the up and down arrow keys, scroll to the **desired voice message**.
OR
Using the AUX VOL shaft encoder, scroll to the **desired voice message**.
2. Press the **SEL** button.
Playback icons appear in the keypad display window. By default, the PLAY button is selected.
3. Press the **SEL** button.
The voice message is played.

To **rewind or fast forward a message**, do the following:

- > Press and hold the **rewind (left arrow) key** to rewind a message
OR
Press and hold the **fast forward (right arrow) key** to fast forward the message.

NOTE:

- Tapping the fast forward or rewind keys moves the message 1 second forward or 1 second backward.
- Pressing the SEL button toggles Play/Pause

To **pause the message**, do the following:

1. Press the **SEL button**.
Playback icons appear in the keypad display window.
2. Press the **SEL button**.
The message begins to play. A pause icon appears.
3. Press the **SEL button**, again.
The message is paused.

To **return a call to the caller who left the voice message**, do the following:

NOTE: This action can be done from both the Voice Messages and VM Playback menus.

- > With a voice message highlighted, press down on the **CWW key**.
The person who initially left the message is called back.

NOTE: When pressing the CWW talk key, the menu highlight moves to the caller alpha and is shown in green.

To **delete a voice message from the message queue**, do the following:

- > With the message highlighted you want to delete, press the **SHIFT+CLR buttons**.
The message is deleted.

User Programmable Buttons

A UPG (User Programmable Button) gives you the option to assign frequently used menu items to a single button on the keypad, eliminating the need to navigate through the menu structure. Not all menu items can be programmed to the UPG buttons, such as any assignment group menu, any TIF menu items, or scrolling menu items. Basically, any menu that requires context or history cannot be saved. If a menu item cannot be saved, a prompt appears in the panel display showing *Cannot save this menu position*.

NOTE: You can program a UPG key to activate the screen saver option on the keypad. For more information, see “To activate the screen saver from a UPG key” on page 65.

The UPG keys can also be used to activate relays. When a relay is assigned to the button, and while the keypad is not in menu mode, pressing the UPG key activates the relay for as long as the UPG button is held down. Once the button is released, the relay becomes inactive.

NOTE: The UPG buttons can be cleared using Key Options|Clear from the keypad menu.

IMPORTANT: On the DKP-4016/4016W keypad there are nine (9) UPG buttons available – UPG1 through 4 are displayed on the keypad, while UPG 5 through 9 are available as the SHIFT version of the left column buttons (MENU, FWD, BACK, UPG3, and UPG4).

To assign a menu item to a UPG button on the DKP-4016/4016W, do the following:

1. On the DKP-4016/4016W keypad, press the **MENU button**.
The Information menu appears.
2. Using the arrow buttons, navigate to the **menu item** you want to assign to a UPG button.
3. Press and hold the **UPG button** for two (2) seconds.
Menu position saved appears in the panel display.

To assign a menu item to a UPG button using the SHIFT menu, do the following:

1. On the keypad, press the **MENU button**.
The Information menu appears.
2. Using the arrow buttons, navigate to the **menu item** you want to assign to a UPG button.
3. Press the **SHIFT button** and then hold the **UPG button** for two (2) seconds.
Menu position saved appears in the panel display.

To assign a relay to a UPG button, do the following:

1. On the DKP-4016/4016W keypad, press the **MENU button**.
The Information menu appears.
2. From the Information menu, using the arrow buttons, select **Service**.
3. Press the **SEL button**.
The Service menu appears.
4. Using the arrow buttons, select **Local GPIO**.
5. Press the **SEL button**.
GPIO Inputs and GPIO Outputs appears in the panel display.
6. Using the arrow buttons, select **GPIO Outputs**.
7. Press the **SEL button**.
Relay 1 and Relay 2 appear in the panel display.
8. Using the arrow buttons, select the **Relay 1**, or **Relay 2**.
9. Press the **SEL button**.
Not Assigned, Talk Key, and UPG 1 through UPG 9 appears in the panel display.

10. Using the arrow buttons, select a **UPG button**.
The relay is assigned to the desired UPG button.

NOTE: Once a relay is programmed to the button, and the keypad is not in menu mode, pressing the UPG button activates the assigned relay until the button is released.

To **activate the screen saver from a UPG button**, do the following:

1. On the DKP-4016/4016W keypad, press the **MENU button**.
The Information menu appears.
2. Using the arrow buttons, select **Service**.
3. Press the **SEL button**.
The Service menu appears.
4. Using the arrow buttons, select **Scrn Saver**.
Activate, Delay and Mode appear.
5. Using the arrow buttons, select **Activate**.
6. Press the **SEL button**.
The screen saver activates on the keypad.
7. Press and hold the **UPG button** you want to assign this option to for two (2) seconds.
Menu position saved appears in the panel display and the screen saver feature is assigned to the UPG button.

Other Common UPG Assignments available:

- UPG Button to trigger panel swap, see “Key Options Menu, Panel Swap” on page 218.
- UPG Buttons to turn keys off with a single press, see “Key Options Menu, Turn Off” on page 221.
- UPG Buttons to DIAL or DROP a TIF, see “Dialing and Hanging Up” on page 245.

Keypanel Color Window

The **Keypanel Color** window, shown in Figure 15, is used to change the text and background colors assigned to function types, key assignments, and talk/listen indications. You can modify local intercom key assignments and function type colors, as well as remote intercom function type colors, giving you the flexibility to distinguish different systems through the use of color patterns.

The Keypanel Color window is only available when the following requirements are met:

- running AZedit version 3.7.0 or later.
- running MCII-e version 2.1.0 or later.

NOTE: Key colors are associated with assignments and assignment types, not the physical keys they are assigned to.

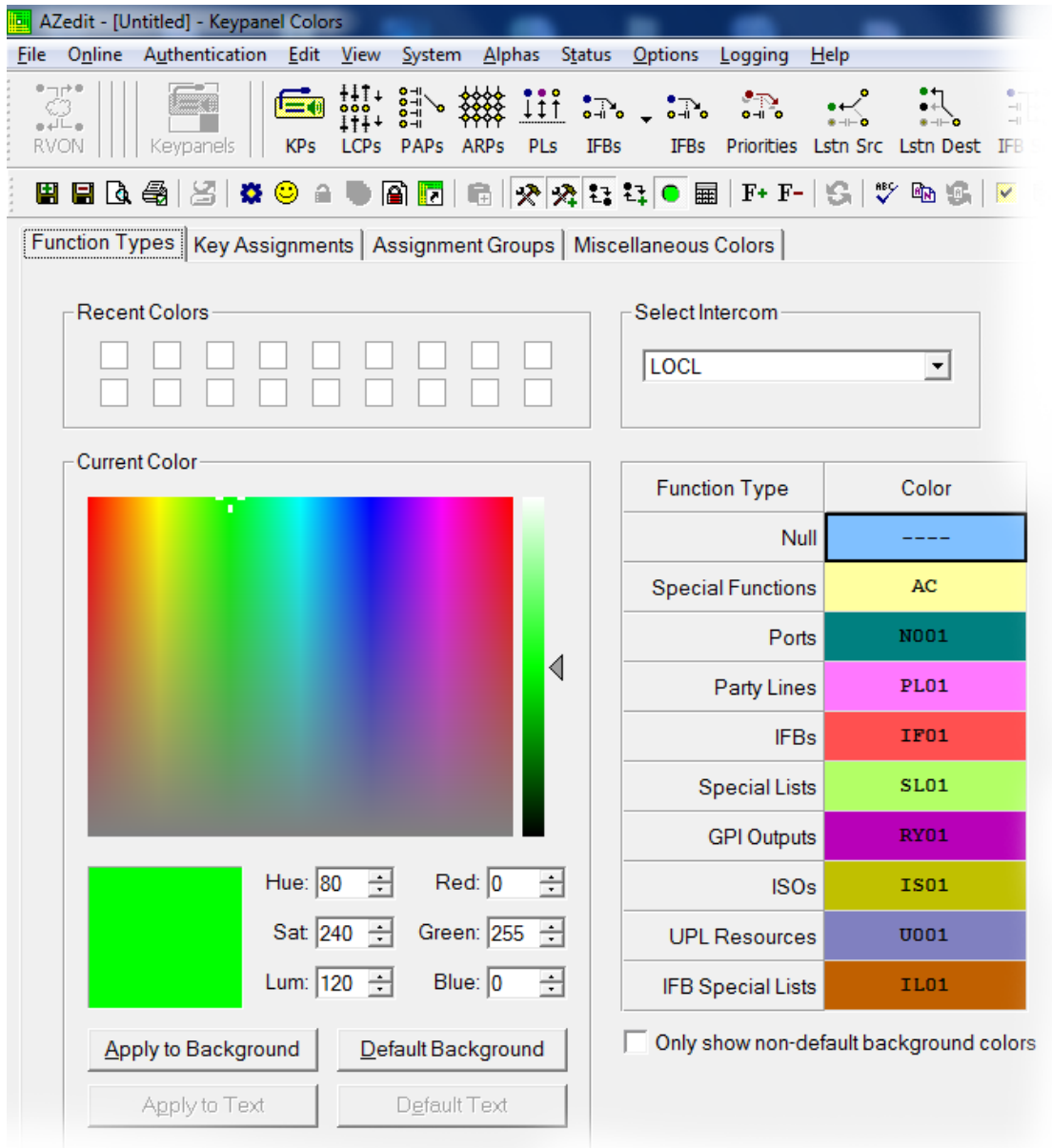

FIGURE 15. Keypanel Colors Window

Function Types Page

The **Function Types** page, shown in Figure 15, is used to change the default colors assigned to the various keypad function types.

Select Intercom Drop Down Menu

The **Select Intercom** drop down menu is used to select the intercom system (*local* or *remote*) in which you want to change the color of the key function types.

Recent Colors Group Box

The **Recent Colors** group box displays the 18 most recently used colors.

Current Color Group Box

The **Current Color** group box displays the currently selected color (current color cell), whether from the color palette or recent colors. Also, using the Hue, Sat, Lum, Red, Green, and/or Blue spin boxes, you can adjust the selected color to create a unique color for the function type.

NOTE: You can drag and drop colors from the color picker or recent color check boxes, and drop it on the background or text area of one (1) of the cells in the Color Grid (Figure 16 on page 68). You can also select a color in the Color Grid and drop and drag it to the Current Color Cell field. By holding down the Ctrl key on the keyboard, you can select multiple cells in the Color Grid, thus allowing you to apply color to multiple key assignments.

Apply To Background Button

The **Apply to Background** button is used to apply the color selection to the background.

Default Background Button

The **Default Background** button is used to reset the background color to the default color.

Apply To Text Button

The **Apply to Text** button is used to apply the color selection to the text of the type of assignment.

Default Text Button

The **Default Text** button is used to reset the text color to the default color of the type of assignment.

Color Grid

Function Type	Color
Null	----
Special Functions	AC
Ports	N001
Party Lines	PL01
IFBs	IF01
Special Lists	SL01
GPI Outputs	RY01
ISOs	IS01
UPL Resources	U001
IFB Special Lists	IL01

FIGURE 16. Color Grid**Function Type Column**

The **Function Type** column displays the different function types you can make key color changes for.

Available selections are: Null, Special Functions, Ports, Party Lines, IFBs, Special Lists, GPI Outputs, ISOs, UPL Resources, and IFB Special Lists.

Color Column

The **Color** column displays the current text and background colors assigned to the function type.

NOTE: You must select the current color box next to the function type you want to change the color for. When selected, a thick black line appears around the box.

Only Show Non-Default Background Colors Check Box

The **Only Show Non-Default Background Colors** check box, if selected, shows colors only for function types set to a color other than their default color.

Key Assignment Page

The **Key Assignment** page, shown in Figure 17, is used to change the colors assigned to the various assignment types. This means you can assign different colors to the individual function type resources. For example, you can change the display color for the party line assignment number 003.

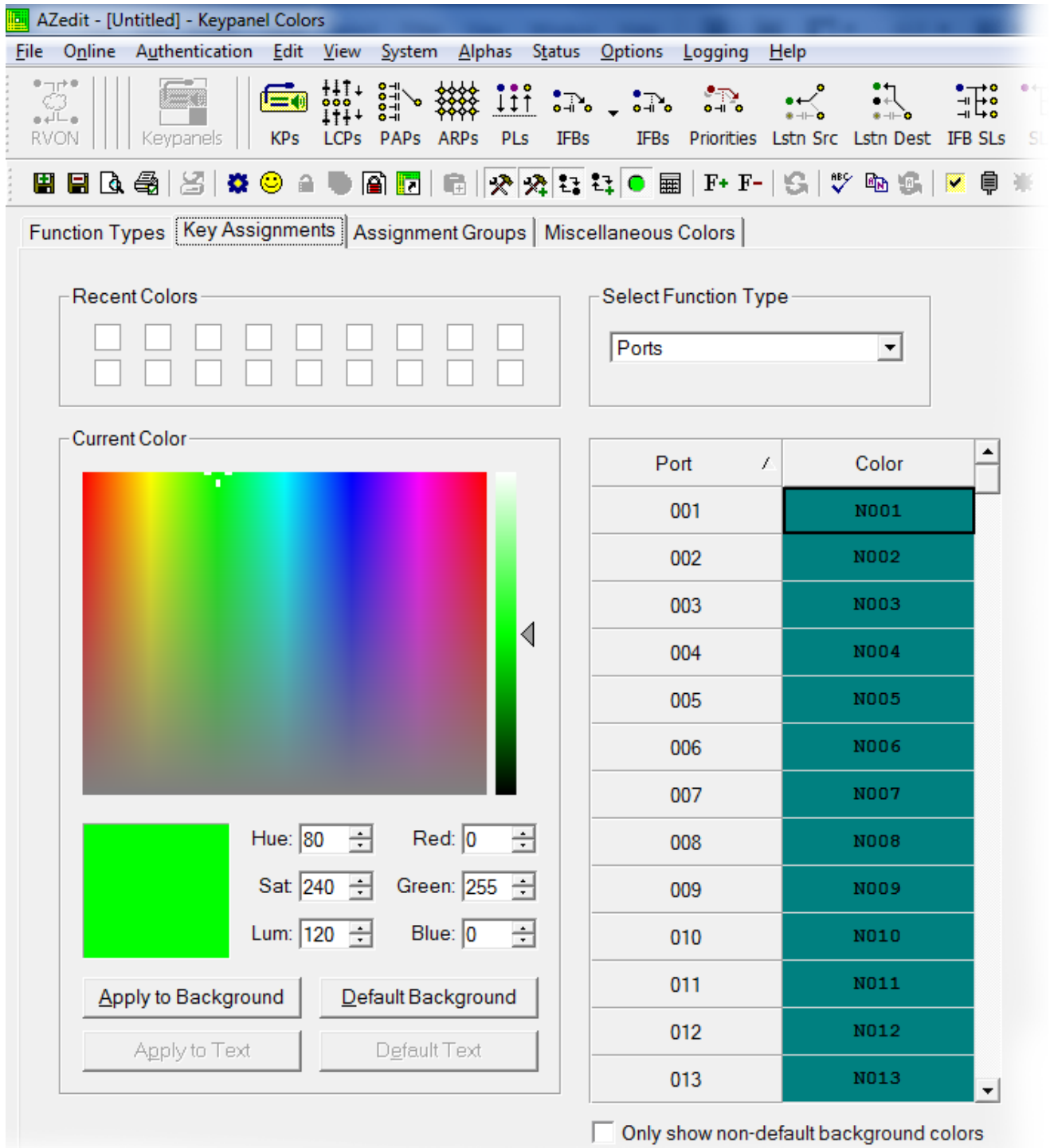

FIGURE 17. Key Assignments Page

Select Function Type Drop Down Menu

The **Select Function Type** drop down menu is used to select the function type you want to display the function number resources for.

Available selections for this field are: Ports, Party Lines, IFBs, Special Lists, GPI Outputs, ISOs, UPL Resources, and IFB Special Lists.

Function Number Column

The **Function Number** column displays the function numbers (resources available) you can modify the color of the assigned key for.

NOTE: Key colors are associated with assignment types, not the keys they are assigned to.

Color Column

The **Color** column displays the current color assigned to the function number.

NOTE: You must select the current color box next to the function number you want to change the color for. When selected, a thick black line appears around the box indicating it is selected.

Assignment Groups Page

The **Assignment Groups** page, shown in Figure 18, is used to change the colors of the members of the different assignment groups.

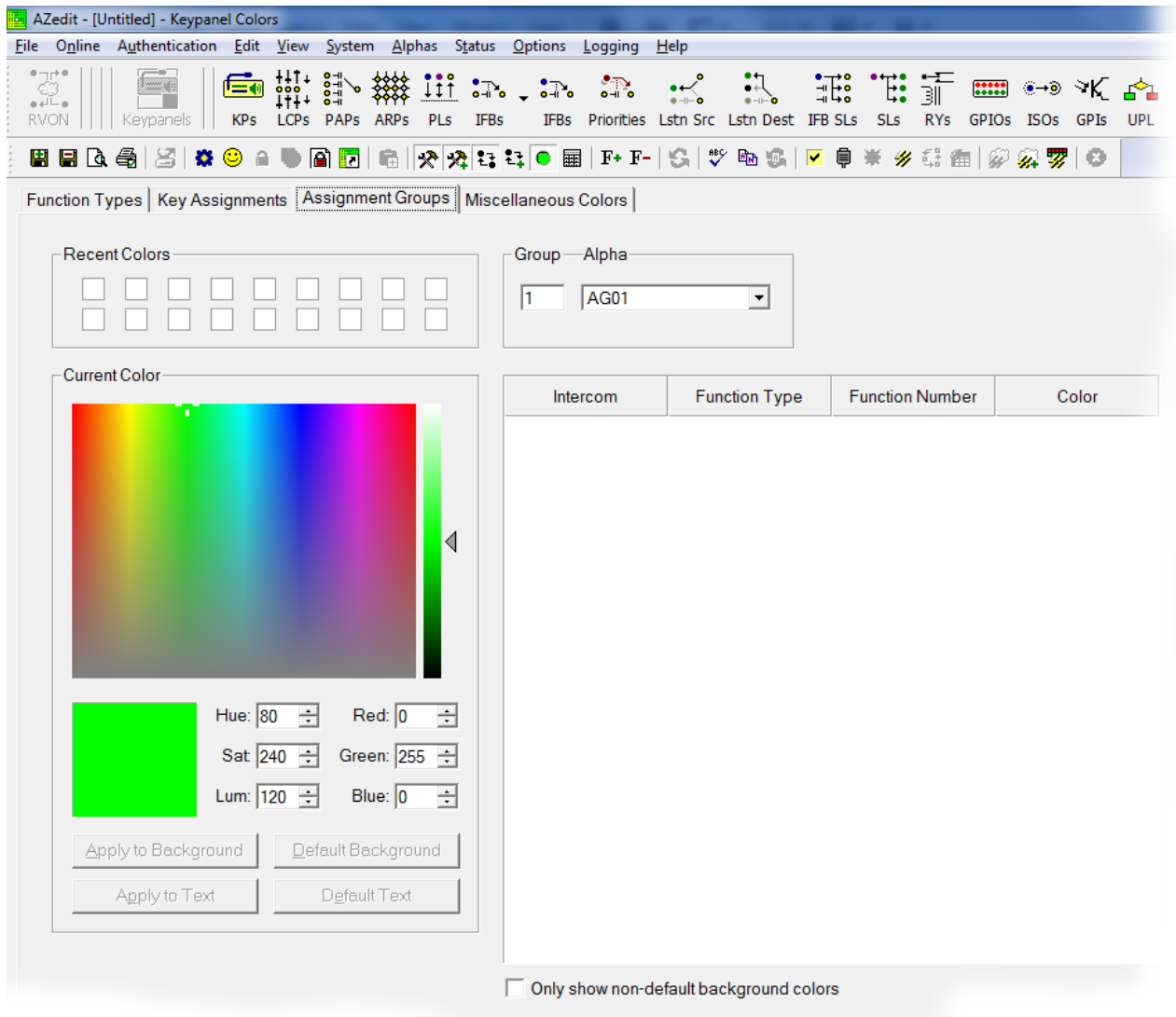

FIGURE 18. Assignments Groups Page

Select Assignment Group Drop Down Menu

The **Select Assignment Group** drop down menu is used to select the assignment group whose members you want to modify the key colors for.

Intercom Column

The **Intercom** column displays the name of the intercom where the group resides.

Function Type Column

The **Function Type** column displays the type function assigned to the group.

Function Number Column

The **Function Number** column displays the number of the assignment group you select from the Assignment Group drop down menu. For more information, see “Select Assignment Group Drop Down Menu” on page 71.

Color Column

The **Color** column is used to select the assignment group member you want to modify the associated color with.

To **select the color column**, do the following:

- > Click the **color box** next to the assignment group member.
A thick, black outline appears around the selected color box.

Miscellaneous Colors Page

The **Miscellaneous Colors** page, shown in Figure 19, is used to change the colors of the talk and listen indicators seen on the DKP-4016/4016W series keypanel when talk and/or listen is activated.

For more information on Talk and Listen indicators, “Talk/Listen Indicator” on page 42.

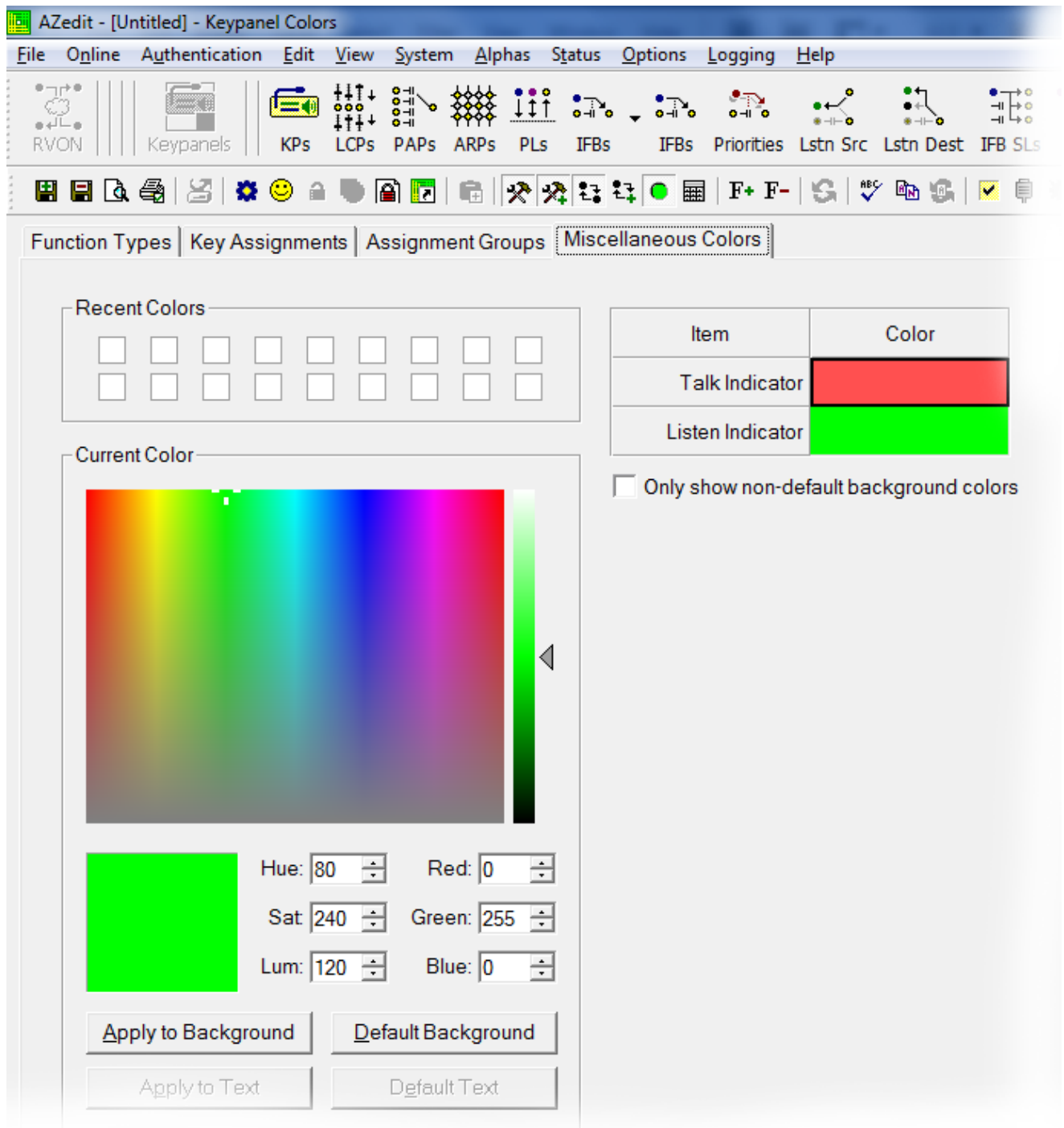

FIGURE 19. Miscellaneous Colors Page

Enhanced Tallies

Enhanced Tallies allow you to configure, using AZedit, how tallies look on the keypanel. You are able to change how an incoming calls, PLs, IFBs, etc look on the keypanel. By default, an incoming call tally is indicated by a flashing alpha. With enhanced tallies, you can configure the text and background colors to trade-off, simulating a flashing keypanel. You can also configure a chime to be played when an incoming call is received, as well as an icon to appear announcing the call. For more information, see Table 8, “Tally Icon Descriptions,” on page 81.

Requirements

AZedit version 5.0.0 or later

MCII-e version 3.2.0 or later

To **open the Enhanced Tallies window**, do the following:

1. Open **AZedit**.
2. From the menu bar, select **System|Miscellaneous|Enhanced Tallies**.
The Enhanced Tallies window appears.

Tally #	Mode	Description	Duration	Characteristics	Chime #	Duration	Legacy Action
1	Flash Text	Incoming call	10 seconds	Text	<none>		Incoming Call Tally
2	No Tally	Extend call	Indefinite	Text	<none>		In Use Tally
3	Flash Text	Trunk in use	Indefinite	Text	<none>		In Use Tally
4	Show Icon	Trunk busy	Indefinite	Text	<none>		Busy Tally
5	Flash Text	IFB in use	Indefinite	Text	<none>		In Use Tally
6	Flash Text	IFB busy	Indefinite	Text	<none>		Busy Tally
7	Flash Text	PL in use	10 seconds	Text	<none>		Incoming Call Tally
8	Flash Text	General in-use	Indefinite	Text	<none>		In Use Tally
9	Flash Text	TIF off-hook	Indefinite	Text	<none>		In Use Tally
10	Flash Text	TIF ringing	Indefinite	Text	<none>		Busy Tally
11	No Tally	Tally #11			<none>		
12	No Tally	Tally #12			<none>		
13	No Tally	Tally #13			<none>		
14	No Tally	Tally #14			<none>		
15	No Tally	Tally #15			<none>		
16	No Tally	Tally #16			<none>		
17	No Tally	Tally #17			<none>		
18	No Tally	Tally #18			<none>		
19	No Tally	Tally #19			<none>		
20	No Tally	Tally #20			<none>		

TABLE 6. Enhanced Tallies Window

Tally # Column

The **Tally #** column displays the tally number. This number is associated with the tally description and is used in creating UPL statements. AZedit supports 20 different tallies, however, the first 10 are predefined.

TABLE 7. Predefined Tallies

Tally #	Description
1	Incoming Call
2	Extend Call
3	Trunk in Use
4	Trunk Busy
5	IFB in Use
6	IFB Busy
7	PL in Use
8	General In Use
9	TIF Off-Hook
10	TIF Ringing

Mode Column

The **Mode** column is used to select the type of tally to use.

There are three (3) options available:

No Tally

Flash Text Flashes text for a user-determined (duration column) amount of time.

Flash Icon Shows an icon for a user determined (duration column) amount of time. For more information, see Table 8, "Tally Icon Descriptions," on page 81.

Description Column

The **Description** column is used to enter a description of the tally you create.

IMPORTANT: It is recommended you do not change the pre-defined tallies descriptions. Changing the description does not change pre-defined purpose of the tally. For example, if you change the description for IFB Busy to Trunk Busy, it still activates when an IFB is busy and may be confusing to users.

To **change the Description column**, do the following:

1. In the Description column, double-click the **tally description** you want to change.
The selected Description cell becomes active.
2. In the cell, enter the **tally description** you want.

Duration Column

The **Duration** column is used to select the duration the tally is activated for.

Available options for this field are: Indefinite and one (1) second through five (5) minutes.

To **set the tally duration**, do the following:

1. In the Duration column, select the **duration of the tally** you want to change.
A drop down menu appears.
2. From the drop down menu, select the **desired duration**.

Characteristics Column

The **Characteristics** column is used to configure the characteristics or behavior of the visual tally. Depending on what you select in the Mode column determines what is seen in this column. From the Characteristics column, you can access a configuration window for either Text or Icon selections. If No Tally is selected in the Mode column, the Characteristics column is blank.

To **open the Text configuration window**, do the following:

1. In the Characteristics column, click the **cell with the word Text**.
The cell animates the tally as defined (for example, flashing text with color or animating icons) and an ellipsis button appears in the cell.
2. Click the **Ellipsis button**.
The Flash Text Characteristics window appears. For more information, see "Flash Text Characteristics Window" on page 78.

To **open the Icon configuration window**, do the following:

1. In the Characteristics column, click the **cell with word Icon**.
An ellipsis button appears in the cell next to the word Icon.
2. Click the **Ellipsis button**.
The Show Icon Characteristics window appears. For more information, see "Show Icon Characteristics Window" on page 80.

Chime # Column

The **Chime #** column is used to select the type of chime to play when a tally is activated.

Available options for this field are: System Chime #1 through System Chime #12. User Chime #1 through #4 appear if the Audio Package is installed.

To **set the chime**, do the following:

1. In the Chime # column, select the **chime cell** you want to change.
A drop down menu appears.
2. From the drop down menu, select the **desired chime**.

Duration Column

The **Duration** column is used to select the length of time for the chime to last.

Available options for this field are: One-shot and one (1) second through five (5) minutes.

To **set the duration of the chime**, do the following:

1. In the Duration column, select the **duration of the tally** you want to change.
A drop down menu appears.
2. From the drop down menu, select the **desired duration**.

Legacy Action Column

The **Legacy Action** column is used to select how the tally descriptions is implemented on keypanels that do not support Enhanced Tallies.

Available options are:

No Tally
Incoming Call Tally
In-Use Tally
Busy Tally

To **select a legacy action**, do the following:

1. Click in the **Legacy Action column cell** desired.
A drop down arrow appears.
2. From the Legacy Action drop down menu, select **desired action**.

Tally #	Description	Duration	Characteristics	Chime #	Duration	Legacy Action
1	Incoming call	10 seconds	Text	<none>		Incoming Call Tally
2	Extend call	Indefinite	Text	<none>		No Tally
3	Trunk in use	Indefinite	Text	<none>		Incoming Call Tally
4	Trunk busy	Indefinite	Text	<none>		In Use Tally
						Busy Tally

Flash Text Characteristics Window

The **Flash Text Characteristics** window is used to configure the way a text tally behaves for the selected tally.

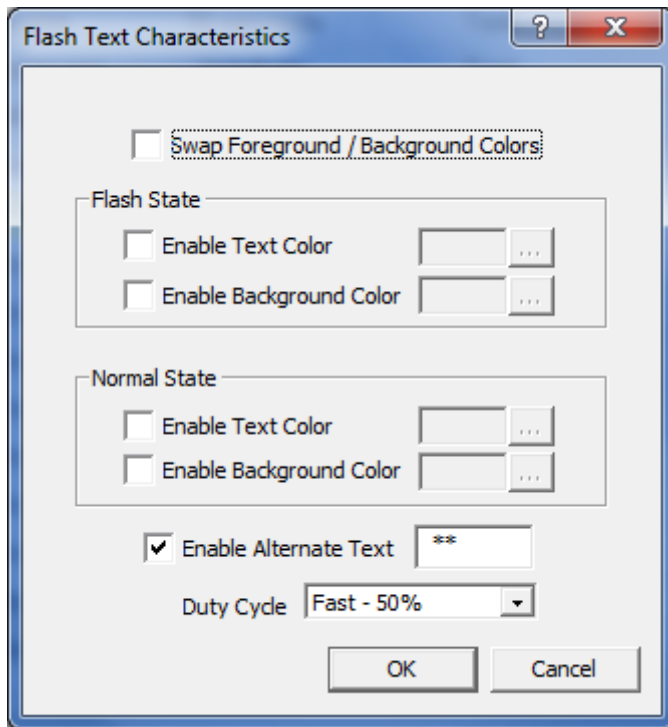

FIGURE 20. Flash Text Characteristics Window

Swap Foreground / Background Colors Check Box

The **Swap Foreground / Background Colors** check box indicates the foreground color swaps with the background color creating a blinking effect on the keypad display.

Flash State Group Box

The **Flash State** group box is used to assign text and background colors used when a tally state is flashing.

Enable Text Color Check Box

The **Enable Text Color** check box enables the Selected Color cell and Browse button. This means you can modify the color of the Text displayed.

Selected Color Cell and Ellipsis Button

The **Selected Color** cell displays the currently selected color of the text.

The **Ellipsis** button opens the Select Color window where you can assign a different color to the text.

Enable Background Color Check Box

The **Enable Background Color** check box enables the Selected Color cell and Browse button. This means you can modify the color of the Background displayed.

Selected Color Cell and Ellipsis Button

The **Selected Color** cell displays the currently selected color of the background.

The **Ellipsis** button opens the Select Color window where you can assign a different color to the background.

Normal State Group Box

The **Normal State** group box is used when the tally is active and is not in the flash state. If there is no tally active, then the colors are whatever is defined for the assignment in the intercom.

Enable Text Color Check Box

The **Enable Text Color** check box enables the Selected Color cell and Browse button. This means you can modify the color of the Text displayed.

Selected Color Cell and Ellipsis Button

The **Selected Color** cell displays the currently selected color of the text.

The **Ellipsis** button opens the Select Color window where you can assign a different color to the text.

Enable Background Color Check Box

The **Enable Background Color** check box enables the Selected Color cell and Browse button. This means you can modify the color of the Background displayed.

Selected Color Cell and Ellipsis Button

The **Selected Color** cell displays the currently selected color of the background.

The **Ellipsis** button opens the Select Color window where you can assign a different color to the background.

Enable Alternate Text Check Box and Entry Field

The **Enable Alternate Text** check box and entry field is used to enter alternate text or characters that appears intermittently with the existing tally text.

This field can contain up to four (4) characters.

Duty Cycle Drop Down Menu

The **Duty Cycle** drop down menu is used to select the rate the tally flashes.

Available options for this menu are:

<i>On Solid</i>	There is no flash
<i>Slow 25%</i>	The alternate text appears for 25% of the flash period (1/4 of a second), while the normal mode appears for 75% of the flash period (3/4 of a second)
<i>Slow 50%</i>	The flash and normal mode appear for 50% of the flash period (1/2 second each)
<i>Fast 50%</i>	The flash and the normal mode appear for 50% of the flash period in alternating pattern (1/4 second flash, 1/4 second normal mode, 1/4 second flash, 1/4 second normal mode)
<i>Fast 75%</i>	The flash appears for 75% (3/4 second), while the existing text appears for 25% (1/4 of a second) of the flash period.

NOTE: The flash period is one second.

OK Button

The **OK** button is used to accept/apply the changes and close the window.

Cancel Button

The **Cancel** button is used to reject the changes and close the window.

Show Icon Characteristics Window

The **Show Icon Characteristics** window is used to configure which icon to display during a tally event and the rate at which it flashes during the event.

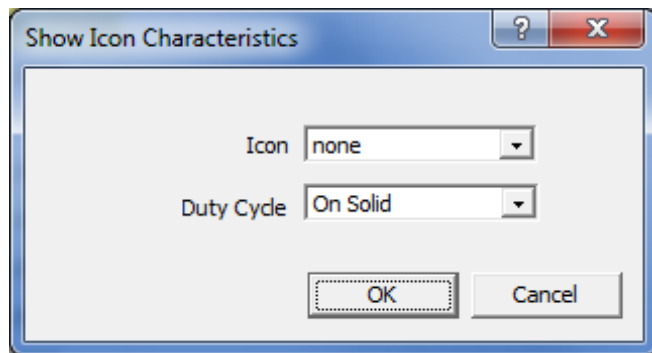

FIGURE 21. Show Icon Characteristic Window

Icon Drop Down Menu

The **Icon** drop down menu is used to select the icon you desire. See “These icons are the default icons sent with the keypanel. These icons can be used for any purpose. Not all the icons are used as defaults. The descriptions in Table 8 are just suggested uses.” on page 81

Duty Cycle Drop Down Menu

The **Duty Cycle** drop down menu is used to select the rate the icon flashes.

Available options for this menu are:

<i>On Solid</i>	There is no flash
<i>Slow 25%</i>	The alternate text appears for 25% of the flash period (1/4 of a second), while the normal mode appears for 75% of the flash period (3/4 of a second)
<i>Slow 50%</i>	The flash and normal mode appear for 50% of the flash period (1/2 second each)
<i>Fast 50%</i>	The flash and the normal mode appear for 50% of the flash period in alternating pattern (1/4 second flash, 1/4 second normal mode, 1/4 second flash, 1/4 second normal mode)
<i>Fast 75%</i>	The flash appears for 75% (3/4 second), while the existing text appears for 25% (1/4 of a second) of the flash period
<i>Animate</i>	4-frame animation, each frame displays for 25% of the flash period.

NOTE: The flash period is one second.

OK Button

The **OK** button is used to accept/apply the changes and close the window.

Cancel Button

The **Cancel** button is used to reject the changes and close the window.

Enhanced Tally Icons

Enhanced Tally Icons, shown in Table 8, are used to visually alert keypanel users of different events occurring on the keypanel and in the Matrix system. The keypanel ships with these icons built-in by default. However, you can download new icons to the panel using AZedit.

NOTE: These icons are the default icons sent with the keypanel. These icons can be used for any purpose. Not all the icons are used as defaults. The descriptions in Table 8 are just suggested uses.

TABLE 8. Tally Icon Descriptions























Icon	Icon Name	Description
	Target	Incoming Call (animation supported) – A call is coming into the keypanel and the animation toggles the target every half second. Extended Call (animation not supported)– The extended call tally is generated when the key is on for a predetermined amount of time. In English intercoms, five (5) seconds pass before the tally begins, while in Japanese intercoms, two (2) seconds must pass
	Red Star	Trunk In-Use (animation not supported) Trunk Busy (animation supported) – The trunk is busy. The animation toggles the star on/off every quarter of a second.
	Black Star	IFB/ISO In Use (animation not supported) IFB/ISO Busy (animated) - The IFB/ISO is busy. The animation rotates the star on/off every quarter of a second.
	Orange Wave	PL In-Use (animation not supported)
	Gray Gear	General In-Use (animation not supported) - Used in Japanese intercoms. This tally is used to show when other keypanels are doing an action on the keypanel. In a Japanese intercom, if your panel is in-use (i.e., you turn on a talk key to anybody), and I have your assignment on my keypanel, the assignment on my keypanel displays the General In-Use tally, even though we are not talking to each other.

TABLE 8. Tally Icon Descriptions

















Icon	Icon Name	Description
	Red Phone	TIF Ringing (animation supported) - The handset vibrates in the animation.
	Yellow Phone	TIF Offhook (animation supported) - The TIF key is active. The phone slow flashes every half second.
	Exclamation	Available for UPL Tally (animation supported) - The animation is a slow flash every half second.
	Heart	Available for UPL Tally (animation supported) - The animation is a slow flash every half second.
	Question	Available for UPL Tally (animation supported) - The animation is a slow flash every half second.
	Flag	Available for UPL Tally (animation supported) - The animation is a slow flash every half second.
	Person	Available for UPL Tally (animation supported) - The animation is a slow flash every half second.
	Link	Available for UPL Tally (animation supported) - The animation is a slow flash every half second.
	Car	Available for UPL Tally (animation supported) - The animation is a slow flash every half second.
	Lightening Bolt	Available for UPL Tally (animation supported) - The animation is a slow flash every half second.
	House	Available for UPL Tally (animation supported) - The animation is a slow flash every half second.
	Handset	Available for UPL Tally (animation supported) - The animation is a slow flash every half second.
	Lock	Available for UPL Tally (animation not supported)
	Speaker	Available for UPL Tally (animation supported) - The animation is a slow flash every half second.
	Play	Available for UPL Tally (animation supported) - The animation is a slow flash every half second.
	Message	Available for UPL Tally (animation supported) - The animation is a slow flash every half second.
	Red Circle	Available for UPL Tally (animation supported) - The animation is a slow flash every half second.

Panel Tally

Panel Tally is used to notify a keypanel user of an event not specifically belonging to a key; for example, a blinking icon appears when a newscast is on air. Panel tallies are controlled through the use of UPL statements. Multiple UPL statements can be configured, but only one (1) icon displays at a time. Lower numbered icons take priority.

NOTE: The keypanel ships with these icons built-in by default. However, you can download new icons to the panel using AZedit.

Available panel tally icons are:

Suggested Use	Suggested Use
 Alarm, Appointment, Event	 Favorite
 Alarm, Chime, Notify	 Information
 Target, Incoming	 Negative
 Appointment, Event	 On Air
 On-Air, Live	 Warning, Alarm, Alert
 Error	 Sports
 Warning	 Alarm, Chime, Notify
 Positive, Notify	 Good, Affirmative

Create and Download New Icons

IMPORTANT: AZedit V5.2.0 or later include the panel and key icon files.

Key Overlay Icons

An **Overlay Icon** is an icon that lies on top of a key in the keypanel display screen. The keypanel supports and is shipped with 32 icons. However, you can create your own icons.

A single icon is 16 x 16 pixels. AZedit uses bitmaps rather than icon (.ico) files. This is so users can use the system tool Paint to create their icons, instead of a specialized icon editor. 32 icons are supported for key overlays, so the bitmap must be 512 pixels wide (16 pixels x 32 icons). Animation of icons is also supported (4 frames), so the bitmap is 64 pixels tall (16 pixel icons x 4 rows of icons), where each column of icons contains four (4) images for animation of the icon, and each row of icons represent stage 1–4 of the animation for each icon. Figure 22, shows a 512x64 pixel bitmap (a table of 32x4 icons).

IMPORTANT: The following icons are built into the panel. This file is shipped with AZedit so it can be easily copied and modified by the user to create their own icons.

By downloading your own icons, you are replacing the ones built into the keypanel. Retain a copy of the icons shipped with AZedit, in case you want to reuse the default icons.



FIGURE 22. 512 x 64 pixel bitmap of key overlay icons

AZedit accepts a bitmap of narrower width (as long as it is a multiple of 16). This is done by extending the bitmap to 512 pixels by adding white space horizontally. Vertically, the bitmap needs to be 16 pixels high, and then repeat the image 3 more times to make it 64 pixels high. Repeating the icon four times, indicates there is no animation. You can also create a bitmap 32 pixels high (two (2) frames per icon) and repeat the image once to make 64 pixels high (so there would be two frames of animation repeated).

Panel Icons

For **Panel Icons**, the icons are 32x32 pixels. 16 panel icons are shipped with the keypad, as well as 4-frame animation, so the bitmap must be 512x128, producing a table of 16x4 icons (each icon 32x32 pixels), see Figure 23. Like key icons, AZedit accepts a narrower image (as long as it is a multiple of 32) and uses white space to fill in the missing pixels. Shorter images are supported (as long as the image is either 32 or 64 pixels tall) and are replicated (3 times, or once) to get an image measuring 128 pixels tall.

IMPORTANT: The following icons are built into the panel. This file is shipped with AZedit so it can be easily copied and modified by the user to create their own icons.

By downloading your own icons, you are replacing the ones built into the keypad. Retain a copy of the icons shipped with AZedit, in case you want to reuse the default icons.

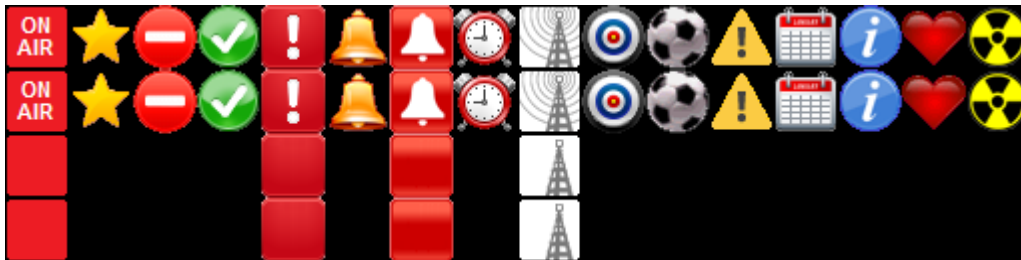

FIGURE 23. 512 x128 pixel bitmap of panel icons

Keypanel Mirroring (Control Package Only)

Keypanel Mirroring allows a licensed DKP-4016/4016W keypanel (licensed as a supervisor) to take control of a target keypanel. All KP-Series keypanels can be the target of mirroring, whereas only licensed keypanels can be the supervisor of a target keypanel. By default, Keypanel Mirroring is disabled. You must enable a panel to be a mirror supervisor using AZedit. This allows any licensed keypanel to initiate a mirroring operation on a local target keypanel.

IMPORTANT: Mirroring is not supported across trunks.



Keypanel Mirroring operates in real-time, meaning when a supervisor keypanel initiates a mirroring operation almost all aspects of the target keypanel functionality are accessible. Once the configuration file is transferred from the target to the supervisor keypanel, the supervisor keypanel looks and behaves like the target. Turning keys on/off, adjusting key volumes or panel volumes on either the target or supervisor keypanel is seen immediately on the other keypanel.

IMPORTANT: If using a DKP to mirror a KP-5032, you do not have access to keys 1-9 or 17-25 because the DKP only mimics the right side of the full 2RU panel.

On the target keypanel, the keypad is locked out, preventing the target keypanel from entering the menu. Any changes to the configuration made by the supervisor keypanel are immediately transferred to the target keypanel.

IMPORTANT: The Supervisor keypanel can change settings for features the Target is licensed for, even if the Supervisor is not licensed. Compression ratios, additional noise gate settings, and the 5-band equalizer settings are all available in the Supervisor (even if it is not licensed for these features) as long as the Target panel is licensed for them. For example, if the target keypanel supports a 5-band EQ and the supervisor keypanel does not, the supervisor keypanel is able to change the EQ settings.

In AZedit, if a keypanel is a mirror Supervisor or Target, an icon is shown in the Port Status area in the Keypanel View.

	Supervisor icon	The Supervisor icon signifies the keypanel is mirroring another keypanel and can make changes to the other keypanel, known as a Target. For more information, see “Service Menu, Mirror (Control Package Only)” on page 234.
	Target icon	The Target icon signifies the keypanel is being mirrored by another keypanel, known as a Supervisor. This keypanel is being remotely controlled by the Supervisor. For more information, see “Service Menu, Mirror (Control Package Only)” on page 234.
***These icons appear on the keypanels involved in the mirror operation.		

IMPORTANT: If you make changes, including real time changes, to a Target Keypanel using AZedit, those changes are also seen on the Supervisor Keypanel. However, if you make changes, including real-time changes, to a Supervisor Keypanel using AZedit, those changes are made to the Supervisor’s saved configuration, but are not implemented until the Supervisor Keypanel exits Mirroring and returns to normal operation.

To **disable mirroring on a keypanel**, do the following:

1. In AZedit, click the **Edit button**. 
The *Keypanel/Port Configuration* window appears.

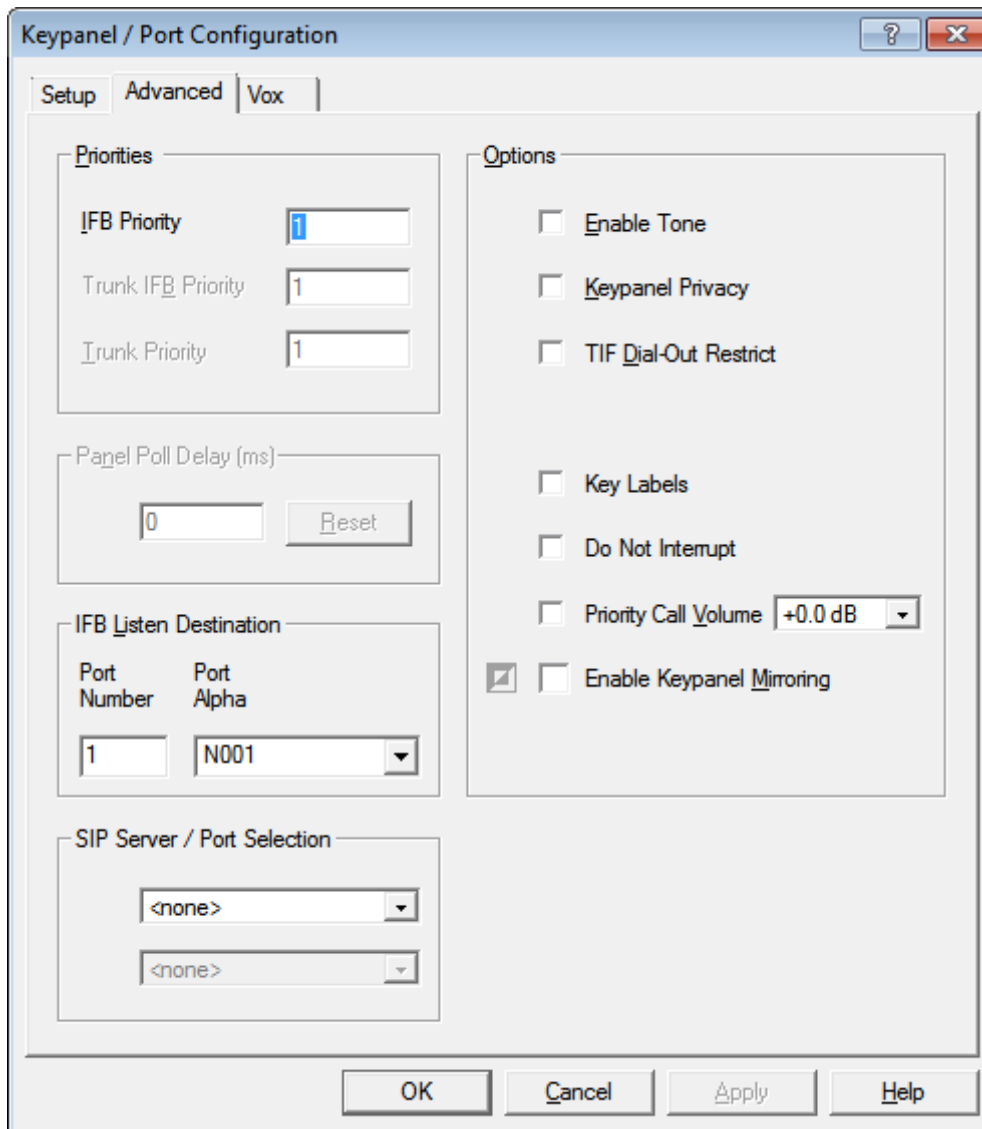

2. Click the **Advanced Tab**.
3. Clear the **Enable Keypanel Mirroring** check box.
4. Send the **changes** to the intercom.

To **enable mirroring on a keypanel**, do the following:

1. In AZedit, click the **Edit button**. 
The *Keypanel/Port Configuration* window appears.

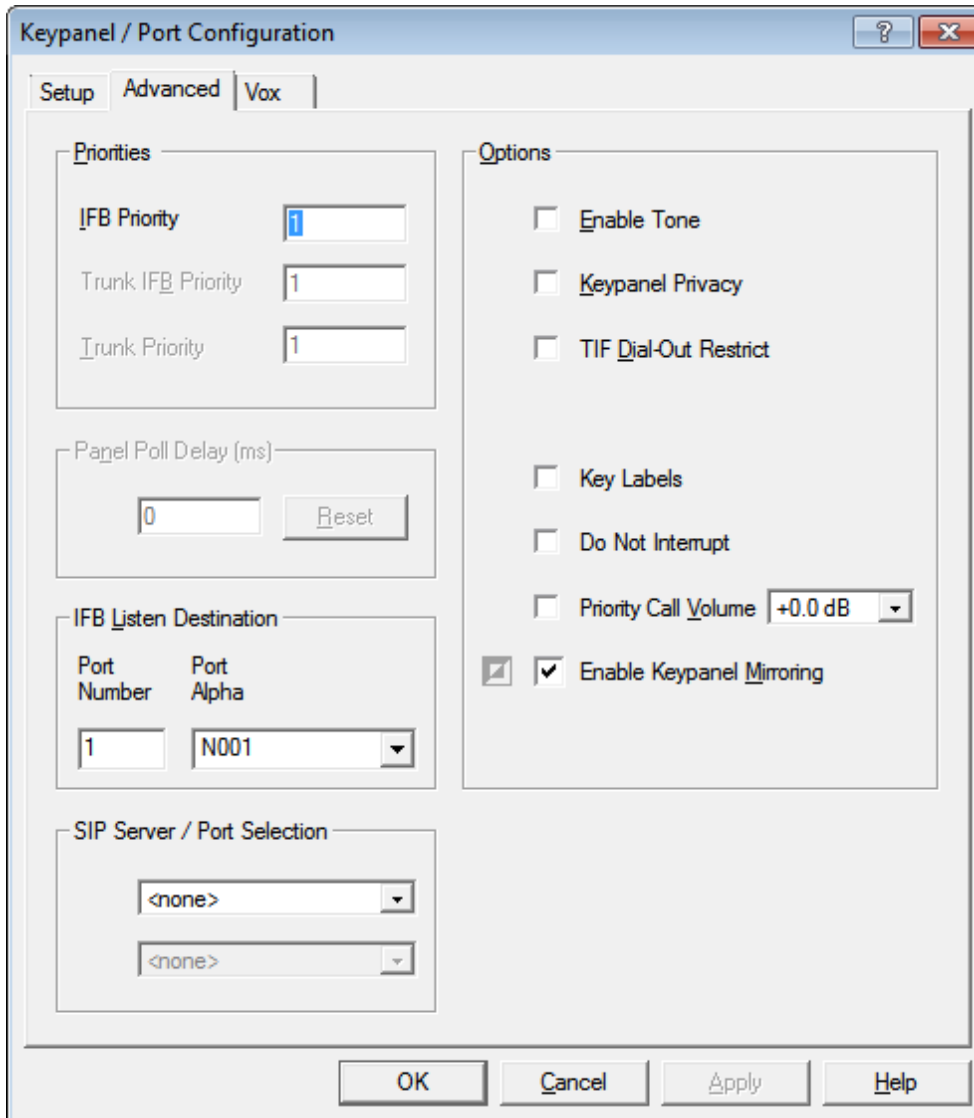

2. Click the **Advanced Tab**.
3. Select the **Enable Keypanel Mirroring check box**.
4. Send **changes** to the intercom.

To **take control of a target keypanel**, do the following:

IMPORTANT: When you enter the Mirror menu looking for a target panel to Mirror, you can only see panels that are locally scroll enabled (ie. if they aren't in your scroll list, you won't be able to mirror them).

1. On the keypanel, starting at the Service menu, select **Mirror**.
2. Press the **SEL button**.
A list of available target keypanels appear in the panel display.
3. Using the arrow buttons, scroll to the **target keypanel**.
4. Press the **SEL button**.
The Supervisor keypanel updates and displays the target keypanel's image.

To **exit Mirror mode on the keypanel**, do the following:

1. On the keypanel, starting at the Service menu, select **Mirror**.
2. Press the **SEL button**.
The alpha of the target and Exit appear in the panel display.
3. Using the arrow buttons or Aux Volume shaft encoder, select **Exit**.
4. Press the **SEL button**.
The mirroring target and supervisor icons disappear and keypanels go back to normal operation.

Real-Time Control in AZedit (Control Package Only)

Real-Time Control allows you to make real-time (immediately applied) changes to intercom and keypanel volume controls as well as muting keypanel microphones, switching headset focus, setting AFK, and enabling tone at selected keypanel ports.

Intercom Volume Controls

Intercom Volume Controls are used to adjust Crosspoint Listen, Party Line Listen, Port Input Gain, and Port Output Gain. Adjustments to these different volumes can be done in real-time or modified and sent to the intercom at a later time.

There are two (2) ways to adjust the intercom volume controls;

- via the Port Volumes window
- opening the individual gain adjustment screens

By default, intercom volumes are set at +0.0dB.

The range for Crosspoint Listen and Party Line Listen is *Mute, -80dB to +6dB*.

The range for the Port Input Gain and the Port Output Gain is *-20dB to +20dB*.

To **enable real-time intercom volume adjustments**, do the following:

1. On the KP/Ports screen, click the **Port Volumes icon**.
The Port Volumes window appears.
 OR
 Right-click in the **keypanel key** field and select **Change Volume**.
The Port Volumes window appears.
- 2.

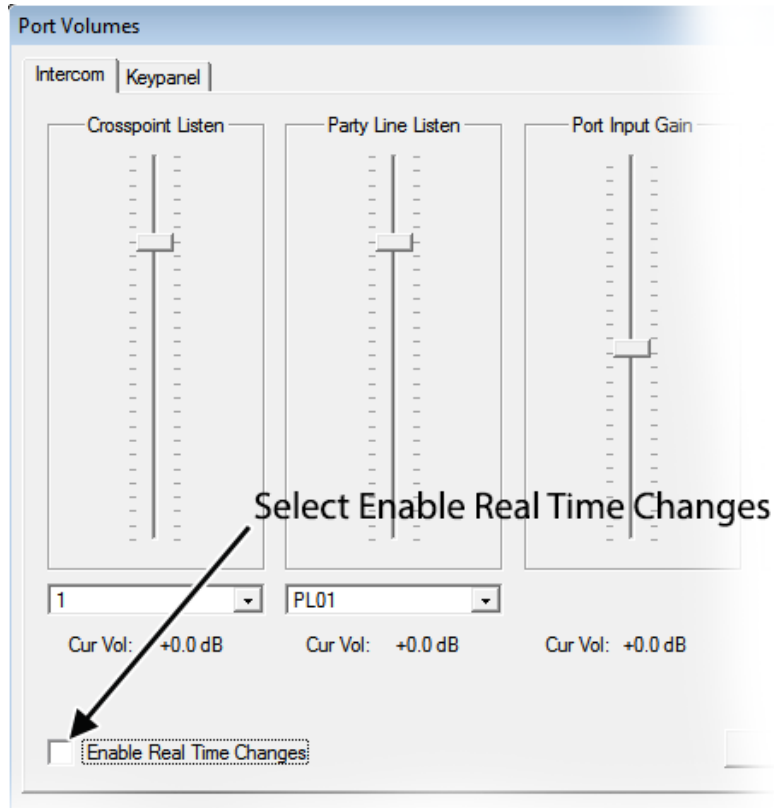

3. In the lower left-hand corner of the window, select the **Enable Real Time Changes check box**.
The Intercom is real-time enabled.

IMPORTANT: When changes have been made to the intercom volumes but have not been sent to the intercom and the Enable Real Time Changes check box is selected, a warning message appears (Figure 24).

- Click Yes to abort all changes to volumes for this port.
- Click No to leave the changes (but don't send them).
- Click Cancel to disable real-time changes.

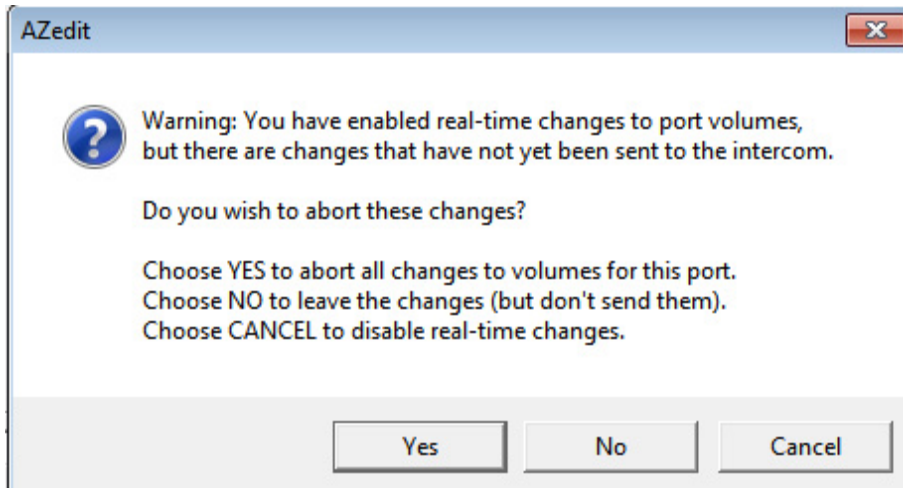
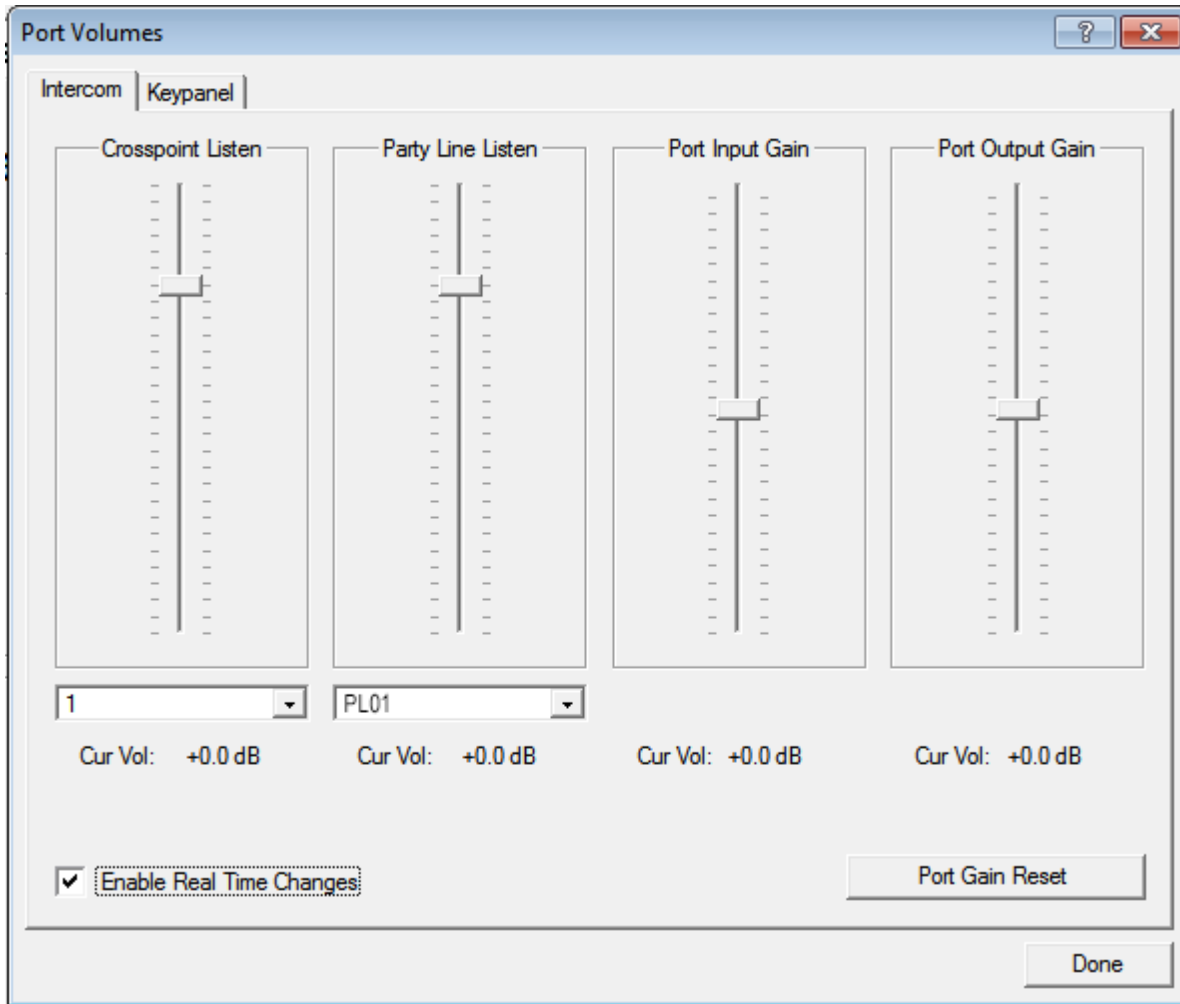

FIGURE 24. Real Time Warning Message

To **adjust the intercom volumes via the Port Volumes window**, do the following:

1. On the KP/Ports screen, click the **Port Volumes icon**.
The Port Volumes window appears.
 OR
 Right-click in the **keypanel key** field and select **Change Volume**.
The Port Volumes window appears..



2. Verify the **Intercom page** is selected.
3. From the alpha drop down menu, select the alpha you want to adjust.(i.e., *N001*).
4. Using the volume sliders, make **adjustments to the volume gain**.

NOTE: If Real-Time is not enabled, send the changes to the intercom.

Keypanel Volume Controls

Keypanel Volume Controls are used to modify volumes on keypanels without physically going to the keypanel to do so. Unlike Intercom Volume Controls, Keypanel Volume Controls are always changed in real-time. However, the real-time controls are only enabled if the keypanel supports it (licensed). Adjustable keypanel volumes include Speaker (minimum and maximum), Headset (minimum and maximum), Matrix In minimum, and Aux In minimum.

By default keypanel volumes are +0.0dB.

The range for Speaker, Headset, Matrix In, and Aux In volumes is: *Mute, -48dB to +10dB*.

To **adjust keypanel volumes**, do the following:

1. On the KP/Ports screen, click the **Port Volumes icon**.
The Port Volumes window appears.
OR
Right-click in the keypanel key and select **Change Volume**.
The Port Volumes window appears..

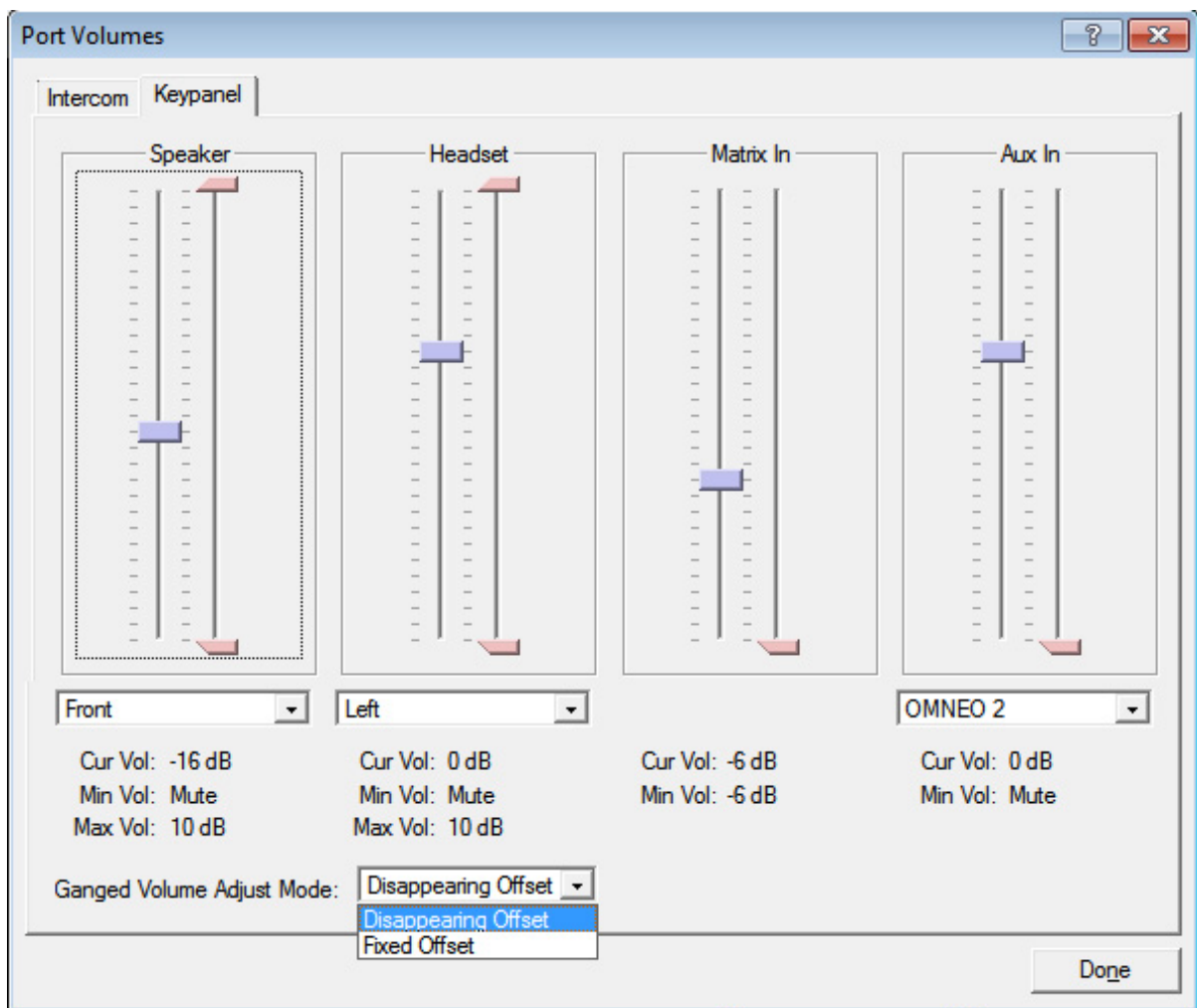

NOTE: When using ganged volumes, four (4) sliders appear in both the Speaker and Headset group boxes. See Figure 25. For more information on Ganged Volumes, see “Audio Options Menu, Ganged Vols” on page 192.

2. From the drop down menu under Speaker, select **Front** or **Rear**.
OR
From the drop down menu under Headset, select **Left** or **Right**.
OR
From the drop down menu under Aux In, select **OMNEO 1 -8** or **AUX 1**.

IMPORTANT: OMNEO 1 can be an Aux channel if the keypanel is connected to the intercom via AIO.

3. From the Ganged Volume Adjust Mode drop down menu, select **Disappearing Offset** or **Fixed Offset**.
4. Using the volume sliders, adjust the **keypanel volume**.

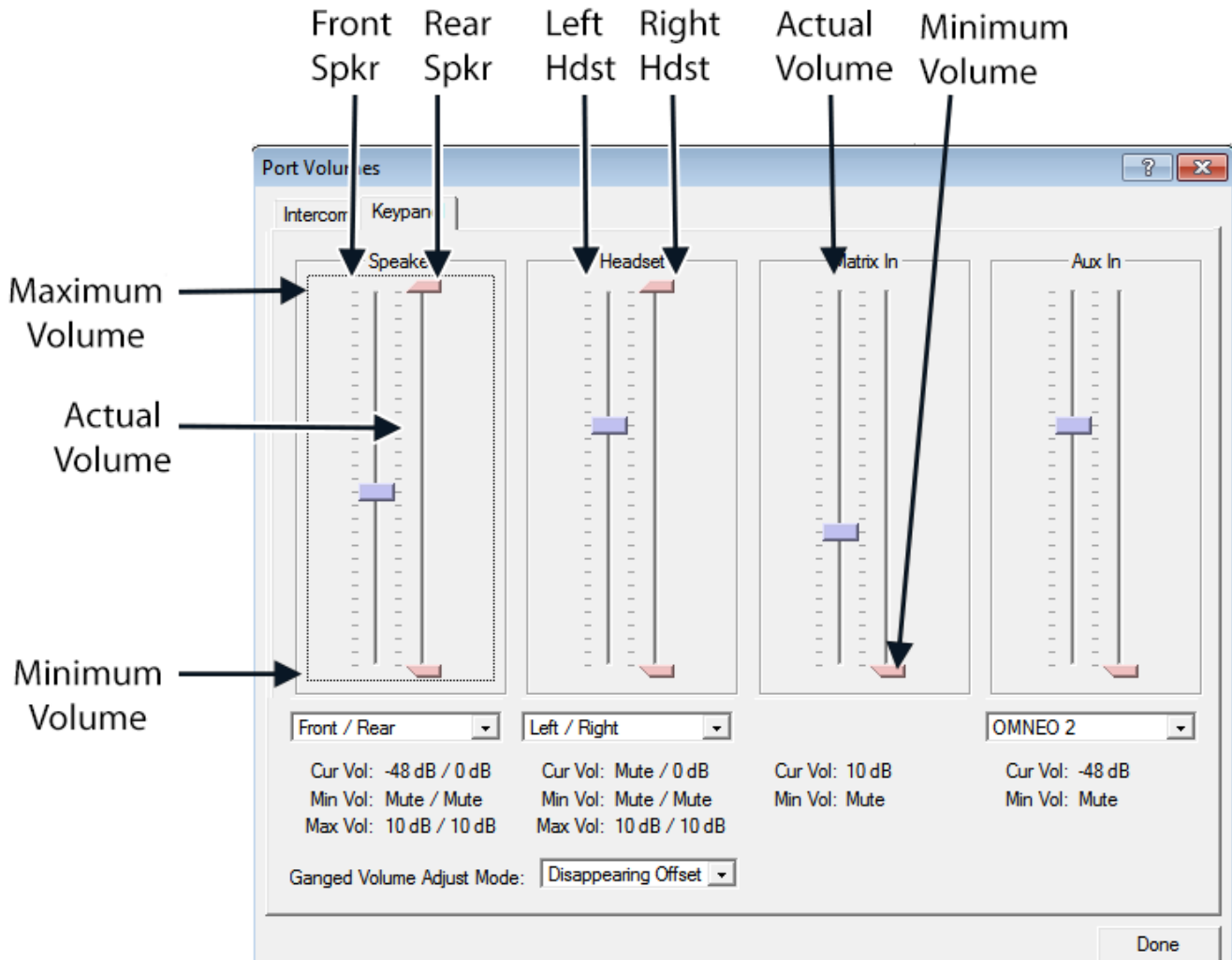

FIGURE 25. When Ganged Volumes are Configured

Mic Mute

Mic Mute is used to remotely enable or disable a selected keypanel (port) microphone from AZedit. This feature requires the Control Package license.

IMPORTANT: When the Mic is muted, the mic mute icon flashes on the keypanel.
When Tone is enabled, the mic mute icon is static on the keypanel.

To **mute a microphone from AZedit**, do the following:

1. From the Port/Alpha group box, select the **port/alpha** of the microphone which you want to mute.
2. Right-click in the **Port Status** group box.
A pop-up menu appears.

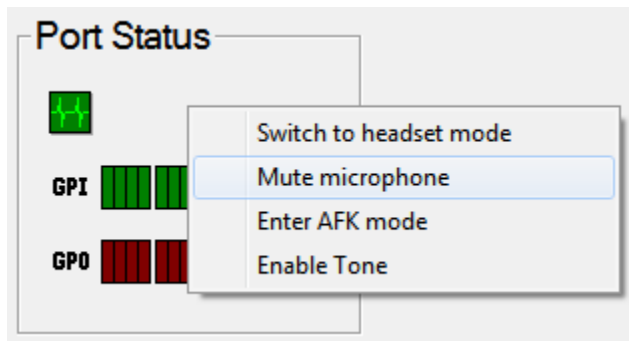

3. From the pop-up menu, select **Mute Microphone**.
A muted mic icon appears in the Port Status group box and a flashing Mic Mute icon appears in the keypanel display screen.

To **unmute a microphone that is muted from AZedit**, do the following:

1. From the Port/Alpha group box, select the **port/alpha** of the microphone you want to un-mute.
2. Right-click in the **Port Status** group box.
A pop-up menu appears.

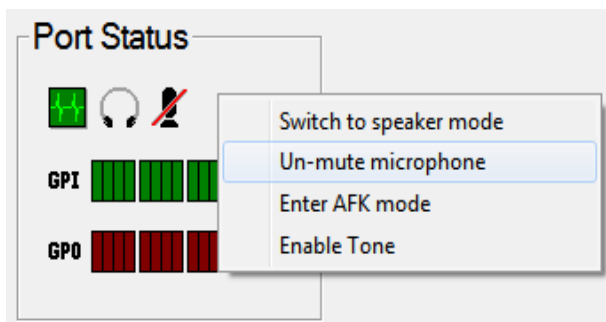

3. From the pop-up menu, select **Un-mute Microphone**.
The muted mic icon disappears in the Port Status group box and the flashing Mic Mute icon stops flashing in the keypanel display screen.

Headset Transfer

Headset Transfer is used to switch between headset and speaker on a selected keypanel/port remotely from AZedit. This feature requires the Control Package license.

To **switch to headset mode on the keypanel from AZedit**, do the following:

1. From the Port/Alpha group box, select the **keypanel port/alpha** of the keypanel you want to switch to headset mode.
2. Right-click in the **Port Status group box**.
A pop-up menu appears.

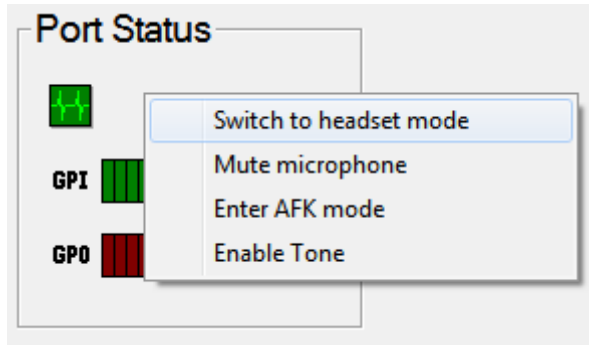

3. From the pop-up menu, select **Switch to headset mode**.
A headset icon appears in the Port Status group box and appears in the keypanel display screen. The keypanel is in headset mode.

To **switch to speaker mode on the keypanel from AZedit**, do the following:

1. From the Port/Alpha group box, select the **port/alpha** of the keypanel you want to switch to speaker mode.
2. Right-click in the **Port Status group box**.
A pop-up menu appears.

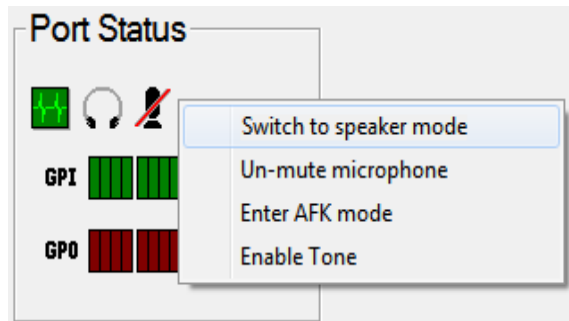

3. From the pop-up menu, select **Switch to speaker mode**.
The headset icon disappears and the speaker icon appears in the Port Status group box and appears in the keypanel display screen. The keypanel is in speaker mode.

AFK Mode

AFK Mode is used to enable and disable **AFK** (Away From Keypanel) on a keypanel/port remotely from AZedit. This feature requires the Control Package license. For more information on AFK, see “Voice Messaging (Audio Package Only)” on page 59.

To **enter AFK mode on a keypanel remotely from AZedit**, do the following:

1. From the Port/Alpha group box, select the **keypanel port/alpha** you want to enable AFK.
2. Right-click in the **Port Status group box**.
A pop-up menu appears.

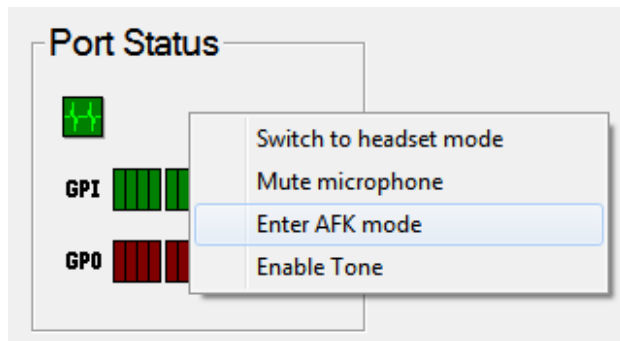

3. From the pop-up menu, select **Enter AFK mode**.
The AFK icon in the Port Status group box and in the keypanel display screen.

To **exit AFK mode on a keypanel remotely from AZedit**, do the following:

1. From the Port/Alpha group box, select the **keypanel port/alpha** you want to exit AFK mode.
2. Right-click in the **Port Status group box**.
A pop-up menu appears.

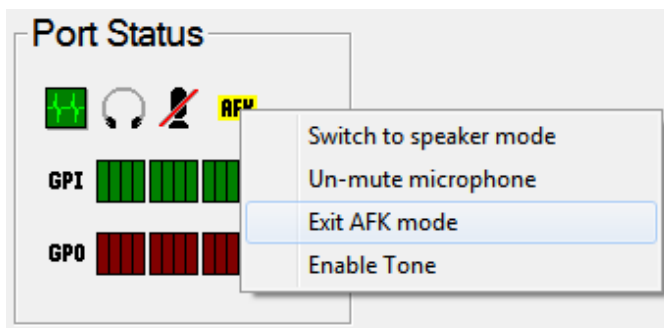

3. From the pop-up menu, select **Exit AFK mode**.
The AFK icon disappears from the Port Status group box and from the keypanel display screen.

Enable Tone

Enable Tone is used to enable and disable the tone generator on the selected keypanel/port from AZedit. This feature requires the Control Package license.

IMPORTANT: When Tone is enabled, the mic mute icon is static on the keypanel.
When the Mic is muted, the mic mute icon flashes on the keypanel.

To **enable tone on the keypanel remotely from AZedit**, do the following:

1. From the Port/Alpha group box, select the **port/alpha** you want to enable tone.
2. Right-click in the **Port Status group box**.
A pop-up menu appears.

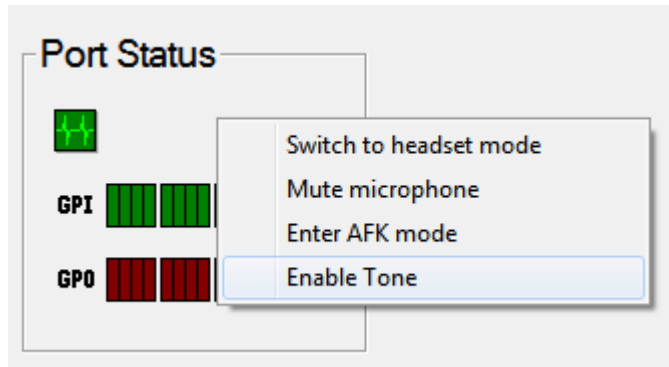

3. From the pop-up menu, select **Enable Tone**.
An enable tone icon appears in the Port Status group box and appears in the keypanel display screen. The keypanel sends a tone to the intercom.

To **disable tone on the keypanel remotely from AZedit**, do the following:

1. From the Port/Alpha group box, select the **port/alpha** you want to disable tone.
2. Right-click in the **Port Status group box**.
A pop-up menu appears.

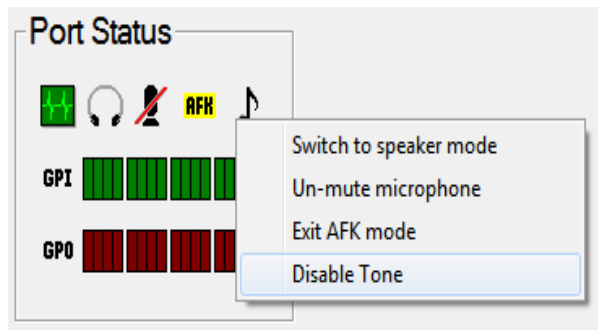

3. From the pop-up menu, select **Disable Tone**.
The enable tone icon disappears from the Port Status group box and disappears from the keypanel display screen.

Keypanel Configuration (Control Package Only)

The **Keypanel Configuration** window gives you the ability to upload a keypanel's configuration file to AZedit, make changes to the configuration, save the configuration, and send it back to the keypanel.

You can also send one configuration file to multiple keypanels from AZedit.

Upload a Configuration File from a Keypanel

Uploading a configuration file from a keypanel can be used to modify an existing keypanel configuration file and/or save it.

To **upload a keypanel's configuration file to AZedit**, do the following:

1. From the Port Alpha group box, enter the **port number**.
OR
From the Alpha drop down menu, select the **Alpha** of the keypanel/port you want to configure.
2. Click the **Keypanel Configuration icon**.

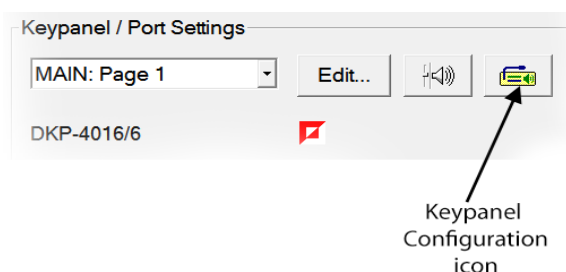

The Keypanel Configuration window appears.

3. Make **modifications to the configuration file**.
4. Click **Apply** to apply the modifications to the keypanel

Load Button

The **Load** button is used to import or merge a saved configuration file on top of the settings you are viewing. The Miscellaneous|Keypanel Configuration menu item allows you to Open a saved configuration file and edit it, which is different from a Load.

OPEN Opens a saved file, which can be modified and re-saved, but not Applied

LOAD Opens an existing configuration file (which can either be opened or uploaded) and then overlays/ merges the contents of a dialog with the contents of the file. It marks everything in the file as changed, but only loads items from that file that were already in the configuration being edited. You can make more changes to the file, save to file, or (if the settings were uploaded) you can Apply them to the keypanel (download to the keypanel)

To **load a configuration file to AZedit**, do the following:

1. From the System menu, select **Miscellaneous|Keypanel Configuration**.
A network folder appears.
2. Navigate to and select the **keypanel configuration file (.kpc file)** you want to load into AZedit.
3. Click **Open**.
The Keypanel Configuration window appears.
4. Make the **necessary modifications** to the file.
5. Click the **Save All** or **Save Changes**.

Save All Button

The **Save All** button is used to save the entire configuration file.

To **perform a save all**, do the following

1. Make **modifications to the configuration file**, as desired.
2. Click the **Save All button**.
The Save Keypanel Configuration window appears.
3. Enter a **unique file name** and make note of where its saved on the network.
4. Click **OK**.
The configuration file is saved.

Save Changes Button

The **Save Changes** button is used to save only modifications in the configuration file.

1. Make **modifications to the configuration file**, as desired.
2. Click the **Save Changes button**.
The Save Keypanel Configuration window appears.
3. Enter a **unique file name** and make note of where its saved on the network.
4. Click **OK**.
The changes are saved.

Apply Button

The **Apply** button is used to download modifications made to the keypanel configuration directly to the keypanel. The **Apply** button is only active if you uploaded the current configuration from a keypanel. If you opened a configuration file using the System\Miscellaneous menu, the **Apply** button is disabled.

IMPORTANT: Applying changes to a keypanel configuration also causes the keypanel to do a Save Config, storing the settings locally.

To **apply changes to the keypanel**, do the following:

1. Make **modifications to the configuration file**, as desired.
2. Click the **Apply button**.
The modifications are sent directly to the keypanel.

Download a Configuration File to Multiple Keypanels

IMPORTANT: Downloading a configuration to a keypanel also causes the keypanel to do a Save Config, storing the settings locally.

To **download a configuration file to one or more keypanels**, do the following:

1. From the Status menu, select **Port**.
The Port Status screen appears.
OR
From the Status menu, select **Software Versions|Keypanels**.
The Keypanel Version Information screen appears.
2. Select the **port(s)** or **keypanel(s)** you want to download the configuration file to.
3. Right-click the selected **port(s)** or **keypanel(s)**.
A popup menu appears.

4. From the popup menu, select **Download Keypanel Configuration...** .
A network folder appears.
5. Navigate to where the **keypanel configuration file is kept.**
6. Select the **file** and click **Open.**
The Download Keypanel Configuration window appears.
7. Click **Begin Download.**

Panel Options Page.

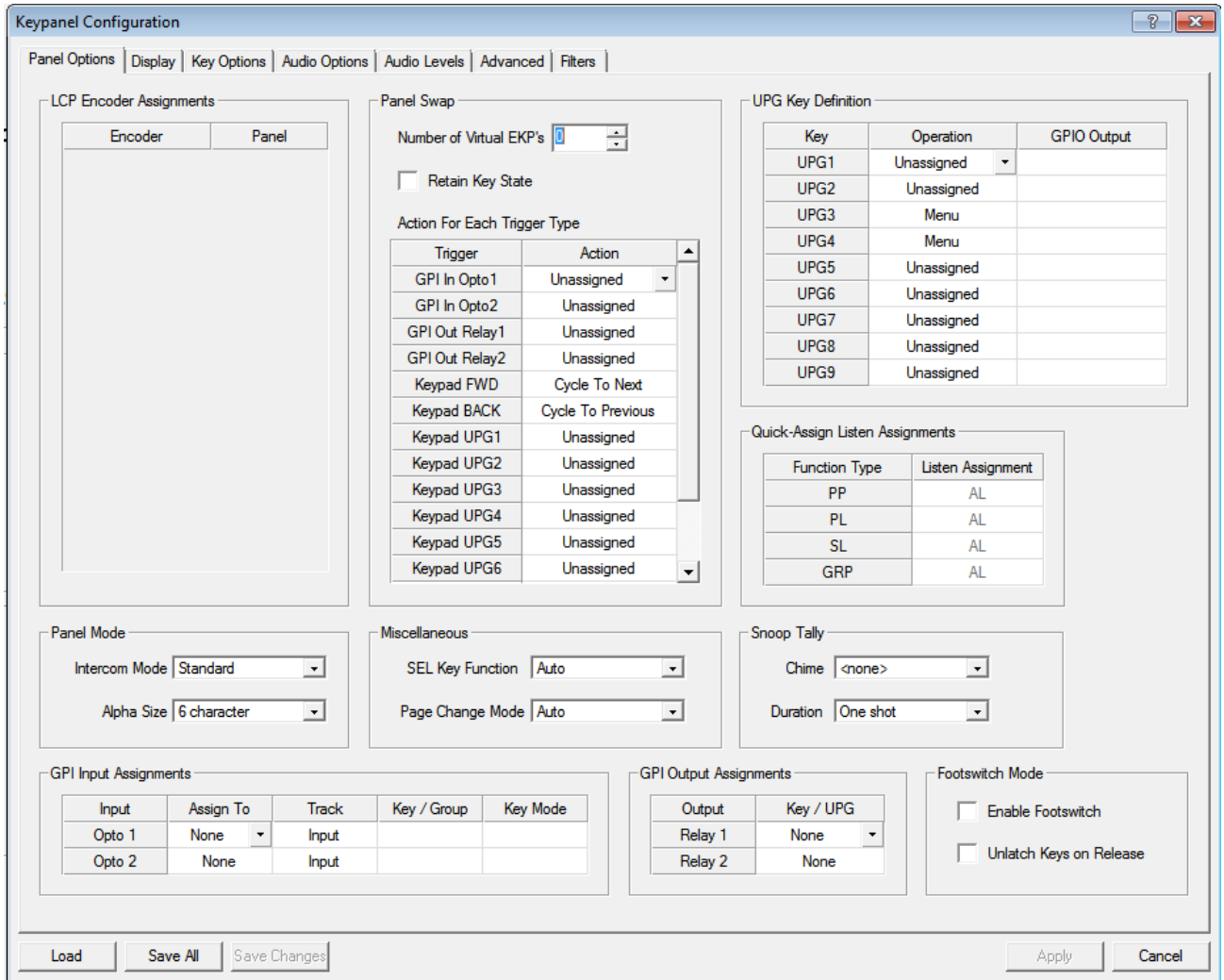

FIGURE 26. Keypanel Configuration – Panel Options

LCP Encoder Assignments Group Box

The DKP-4016/4016W does not support LCP Assignments.

Panel Swap Group Box

The **Panel Swap** group box is used to give users the ability to quickly and easily change a group of keypad assignments on the keypad. This is done through the use of virtual expansion panels. Panel swap differs from changing setup pages because the keys can stay active even when they are no longer visible on the main panel. For a description of the selections available, see “Key Options Menu, Panel Swap” on page 218.

Panel Swap

Number of Virtual EKP's

Retain Key State

Action For Each Trigger Type

Trigger	Action
GPI In Opto1	Cycle To Next
GPI In Opto2	Cycle To Previous
GPI Out Relay1	Switch To MAIN
GPI Out Relay2	Switch To EKP1
Keypad FWD	Cycle To Next
Keypad BACK	Cycle To Previous
Keypad UPG1	Unassigned
Keypad UPG2	Unassigned
Keypad UPG3	Unassigned
Keypad UPG4	Unassigned
Keypad UPG5	Unassigned
Keypad UPG6	Unassigned

FIGURE 27. Panel Options Page – Panel Swap Group Box

To **configure panel swap**, do the following:

1. Using the Number of Virtual EKPs scroll box, enter the **number of virtual EKPs**.
2. Select the **Retain Key State check box** to retain the key states when the keys are not visible (for example, when the page the keys are located is not being displayed).
3. From the Action column next to the key you want to configure, select the **appropriate panel swap action**.

UPG Key Definition Group Box

The **UPG Key Definition** group box is used to assign different inputs and outputs to the UPG keys on the keypad remotely from AZedit. For more information on UPG Buttons, see “User Programmable Buttons” on page 64.

IMPORTANT: Menu Assignments cannot be created from this screen; however, they can be removed.

Key	Operation	GPIO Output
UPG1	Local GPIO Output	Relay 2
UPG2	Unassigned	
UPG3	Menu	
UPG4	Menu	
UPG5	Unassigned	
UPG6	Unassigned	
UPG7	Unassigned	
UPG8	Local GPIO Output	
UPG9	Unassigned	

FIGURE 28. Panel Options Page – UPG Key Definition Group Box

To **configure a UPG key**, do the following:

1. From the Operation column next to the UPG you want to configure, select the **operation** you want.
2. From the GPIO Output column drop down menu, select the **output action** desired.

Quick-Assign Listen Assignments Group Box

The **Quick Assign Listen Assignments** group box is used to assign listen assignment to point-to-point, party line, special list, and group key assignments. Note, this does not change existing keypad assignments, it only affects assignments you make in the future using the Quick Assign function. For more information on listen assignments, see “Operation of Intercom Keys with Auto Functions” on page 51.

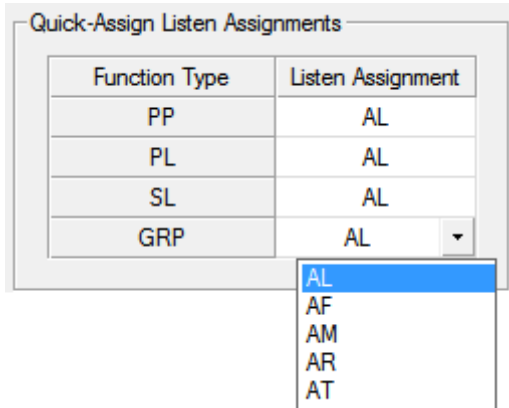

FIGURE 29. Panel Options Page – Quick-Assign Listen Assignments Group Box

To **assign a listen assignment**, do the following:

- > From the listen assignment column drop down menu, select the desired **listen assignment** for the function type.

Panel Mode Group Box

The **Panel Mode** group box is used to configure the keypad’s operating mode and alpha display.

Intercom Mode is used to select the type of firmware you have in your intercom so the keypad can display alphas in the correct font/language and modify the behavior of some functions to match the intercom behavior.

NOTE: Standard mode is the default and should be used in most cases. Alternate mode is primarily used for intercoms running Japanese firmware.

The **Alpha Size** is the number of alpha characters shown in the display panel window.

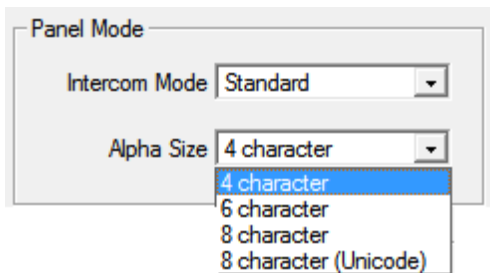

FIGURE 30. Panel Options Page – Panel Mode Group Box

IMPORTANT: The keypad saves its configuration and reboots if the panel mode is changed.

To **configure panel mode**, do the following:

1. From the Intercom Mode drop down menu, select the **Standard** or **Alternate**.
2. From the Alpha Size drop down menu, select **4 character**, **6 character**, **8 character**, or **8 character (Unicode)**.

Miscellaneous Group Box

The **Miscellaneous** group box is used to configure SEL key functions and Page Change Mode.

The **SEL Key** function allows the user to choose what function the SEL key performs when not in menu mode. For a description of the selections available, see “SEL Key” on page 231.

Page Change is used to select whether you are allowed to change setup pages while talk keys are active. By default, in Standard Intercom Mode, page changes are allowed when talk keys are active. However, the default in Alternate Intercom Mode does not allow page changes to occur when talk keys are active. For a description of the selections available, see “Service Menu, Page Change” on page 238.

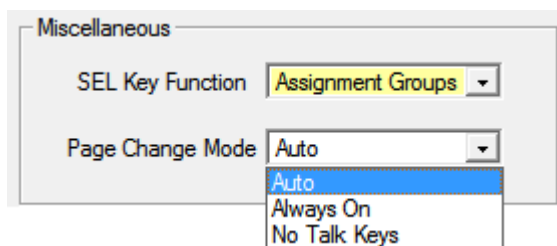

FIGURE 31. Panel Options Page – Miscellaneous Group Box

Snoop Tally Group Box

The **Snoop Tally** group box is used to configure the type and length of the snoop tally, when enabled. The snoop tally indicates to keypad users somebody is listening to them.

For a description of the duration selections available, see “Service Menu, Snoop Tally” on page 241.

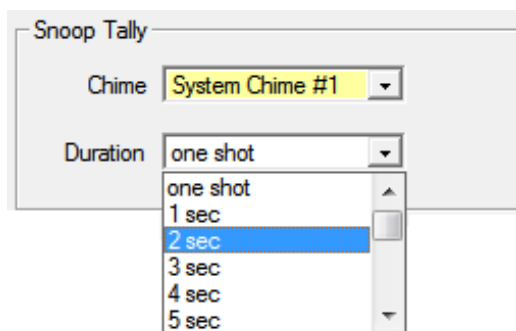

FIGURE 32. Panel Options Page – Snoop Tally Group Box

To **configure the snoop tally**, do the following:

1. From the Chime drop down menu, select the **chime** you want to use.
2. From the Duration drop down menu, select the **duration** you want the chime to sound.

GPI Inputs Assignments Group Box

The **GPI Inputs Assignment** group box is used to configure GPI inputs on the keypanel. Inputs can be assigned to activate intercom keys (including group master keys).

Further configuration can be done to allow GPI Inputs to track the state of the Output. For example, if an output is activated (and is being tracked by an input), the input is also activated. This feature allows GPIO Outputs to control Talk Key or Key Group activation.

In addition to tracking, you can also configure the way an Input GPIO Key Group is configured. By default, when a key group is activated, the keys are forced on until the key group is deactivated. This is referred to as Level Mode. Alternatively, you can configure the key group to Edge Mode. This option turns on keys in a key group when the group is activated, but allows the user to turn off individual keys even if the key group is still active.

For a description of the selections available, see “Service Menu, Local GPIO” on page 232.

Input	Assign To	Track	Key / Group	Key Mode
Opto 1	Key Group	Output	Group 1	Edge
Opto 2	Talk Key	Input	Key 1	

FIGURE 33. Panel Options Page – GPI Input Assignments Group Box

To **configure the GPI Input Assignments**, do the following:

1. From the Assign To column drop down menu, select whether the **input is assigned to a talk key or a key group**.
2. From the Track column drop down menu, select the whether the **input should track the output**.
3. From the Key/Group column drop down menu, select the **key or group** the input is configured to.
4. From the Key Mode drop down menu, select the **behavior of keys in a group** when they are activated.

GPI Output Assignments Group Box

The **GPI Output Assignments** group box is used to assign Relays 1 and 2 to keys on the keypanel.

Output	Key / UPG
Relay 1	UPG 8
Relay 2	Key 42 ▾

FIGURE 34. Panel Options Page – GPI Output Assignments Group Box

To **configure the GPI Output Assignments**, do the following:

- > From the Key/UPG column drop down menu next to the relay you want, select the **key or UPG** you want to assign the relay.

Footswitch Mode Group Box

The **Footswitch Mode** group box is used to enable the footswitch and configure the behavior of keys upon release. For more information, see “Service Menu, Footswitch” on page 226.

To cable for a Footswitch, see “Footswitch Cabling” on page 29.

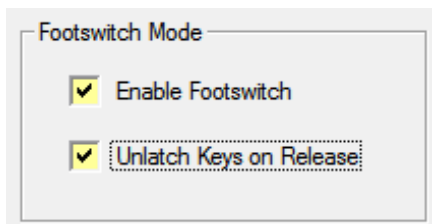

FIGURE 35. Panel Options Page – Footswitch Mode Group Box

To **configure the enable and configure the footswitch**, do the following:

1. Select the **Enable Footswitch check box**.
2. Select the **Unlatch Keys on Release check box** if you want the latched talk keys to become unlatched when the footswitch is released

Display Page

The **Display Page** is used to configure the keypanel and expansion panel displays, including backlight colors, percentage of brightness, screen saver settings, key display options, and panel display options.

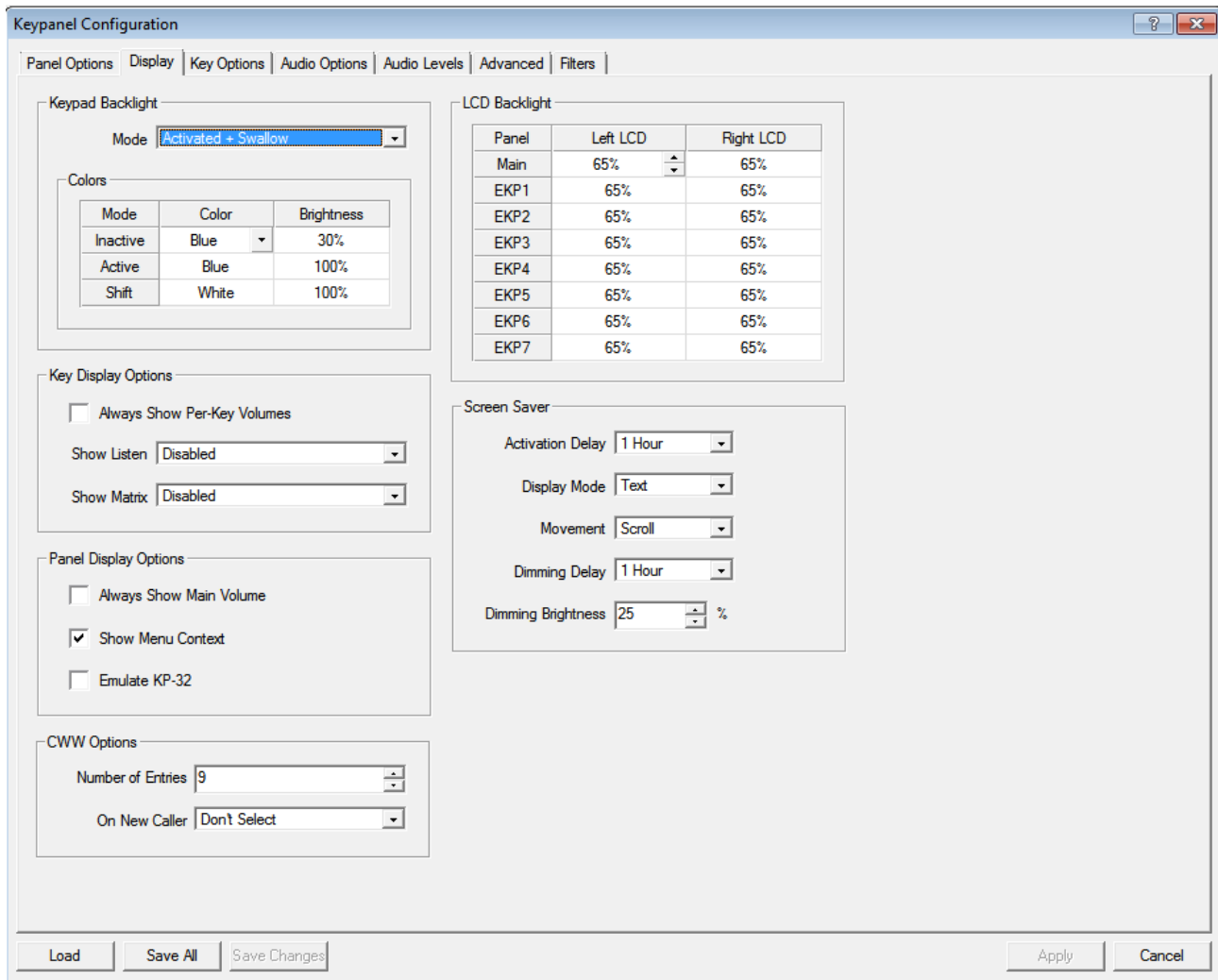

FIGURE 36. Keypanel Configuration – Display Page

Keypad Backlight Group Box

The **Keypad Backlight** group box is used to select the color and brightness of the keypad backlight LEDs at various usage states and to configure the keypad mode.

For more information on the keypad backlight options and descriptions, see “Service Menu, Keypad” on page 229.

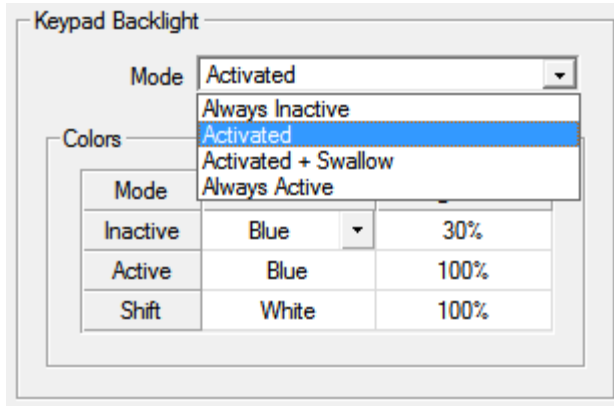

FIGURE 37. Display Page – Keypad Backlight Group Box

To **configure the keypad backlight**, do the following:

1. From the Mode drop down menu, select how the **keypad backlight is activated whether the first keypress is processed or swallowed**.
2. From the Color column drop down menu, select either **Blue** or **White**.
3. From the Brightness column drop down menu, select the **brightness percentage** you desire.

Key Display Options Group Box

The **Key Display Options** group box is used to configure the keypad keys to show key crosspoint gains, show listen assignments, or show the matrix for each key assignment. For more information on the available options, see “Service Menu, Key View” on page 228.

NOTE: Not all options are available in 8-character alpha (or Unicode) mode. This is because the alpha takes two rows to display on the key, and there is insufficient room to show volumes and lstn/mtx assignments.

IMPORTANT: Show Listen and Show Matrix are mutually exclusive options. Only one (1) of these options may be enabled at a time

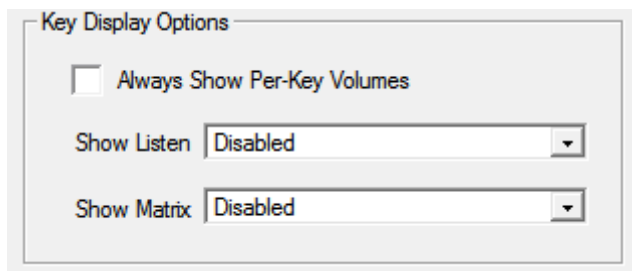

FIGURE 38. Display Page – Key Display Options Group Box

To **configure the keypad display**, do the following:

1. Select the Always Show Per-Key Volumes check box if you want to **display the crosspoint gain for each key** on the keypad.
2. From the Show Listen drop down menu, select **Disabled, Enabled, or Enabled-Suppress Auto-Function.**
3. From the Show Matrix drop down menu, select **Disabled, Enabled, or Enabled-Suppress Local.**

Panel Display Options Group Box

The **Panel Display Options** group box is used to enable the menu context, display speaker volume and to switch the display to emulate a KP-32 keypad. For more information on the available settings, see “Service Menu, Key View” on page 228.

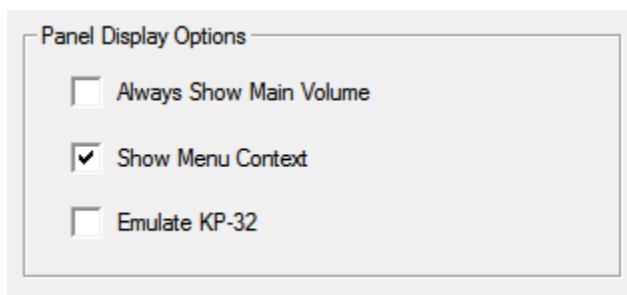

FIGURE 39. Display Page – Panel Display Options Group Box

To **configure the panel display options**, do the following:

1. Select the **Always Show Main Volume check box.**
2. Select the **Menu Context check box** to display the navigational menu above the keypad keys.
3. Select the **Emulate KP-32 check box** to convert the keypad display to look like a KP-32 Classic keypad.

CWW Options Group Box

The **CWW Options** group box is used to configure the CWW. There are two configuration options; how many calls can be shown in the CWW and what happens to the highlight when a new call comes in to the keypanel.

For a detailed explanation of the options available, see “Service Menu, CWW” on page 225.

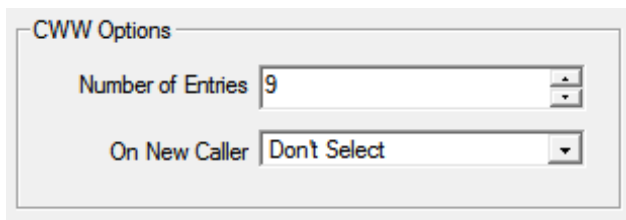

CWW Options

Number of Entries 9

On New Caller Don't Select

FIGURE 40. Display Page – CWW Options

To **configure the CWW options**, do the following:

1. From the Number of Entries drop down menu, select between **3** and **9 entries**.
2. From the On New Caller drop down menu, select **Select New Call**, **Select If Idle** or **Don't Select**.

LCD Backlight Group Box

The **LCD Backlight** group box allows you to set the brightness of the panel display of all keypanels and any expansion panel connected to the main keypanel..

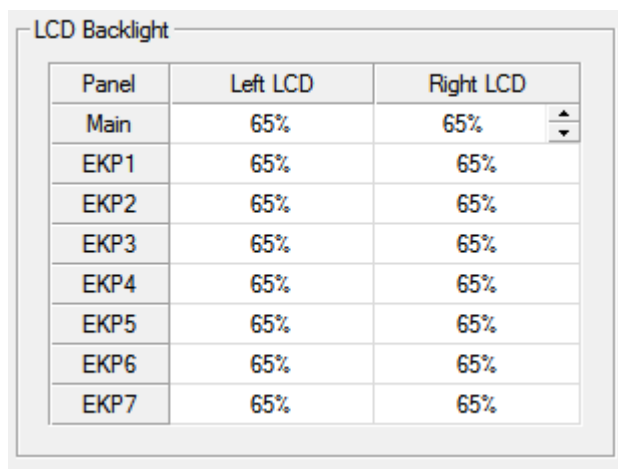

Panel	Left LCD	Right LCD
Main	65%	65%
EKP1	65%	65%
EKP2	65%	65%
EKP3	65%	65%
EKP4	65%	65%
EKP5	65%	65%
EKP6	65%	65%
EKP7	65%	65%

FIGURE 41. Display Page – LCD Backlight Group Box

IMPORTANT: When making changes to the DKP LCD Backlight, the Right LCD drop down menu corresponds to the DKP display panel.

To **configure the LCD Backlight**, do the following:

- > From the Right LCD column spin box menu next to the display you want to set, select the **brightness percentage**.

Screen Saver Group Box

The **Screen Saver** group box is used to configure the screen saver. For more information on the available settings, see “Service Menu, Scrn Saver” on page 239.

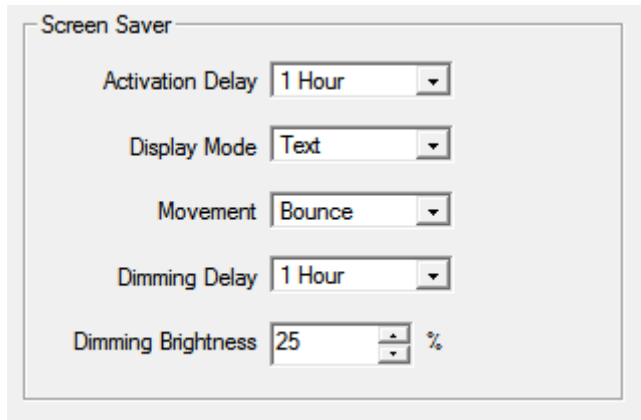

FIGURE 42. Display Page – Screen Saver Group Box

To **configure the screen saver**, do the following:

1. From the Activation Delay drop down menu, select the **amount of inactive time** before the screen saver activates on the keypanel.
2. From the Display Mode drop down menu, select the **display mode** for the screen saver.
3. From the Movement drop down menu, select the **type of movement** the screen saver should display.
4. From the Dimming Delay drop down menu, select the **amount of time** to pass before the display dims.
5. Using the scroll box, scroll to the **percentage the display should dim when dimming delay time is met**.

Key Options Page

The **Key Options Page** is used to configure many of the keypanel operation options, such as auto dial functions, chime keys and duration, exclusive keys, key group assignments, solo key configuration, latching options, button lock, and tally operation.

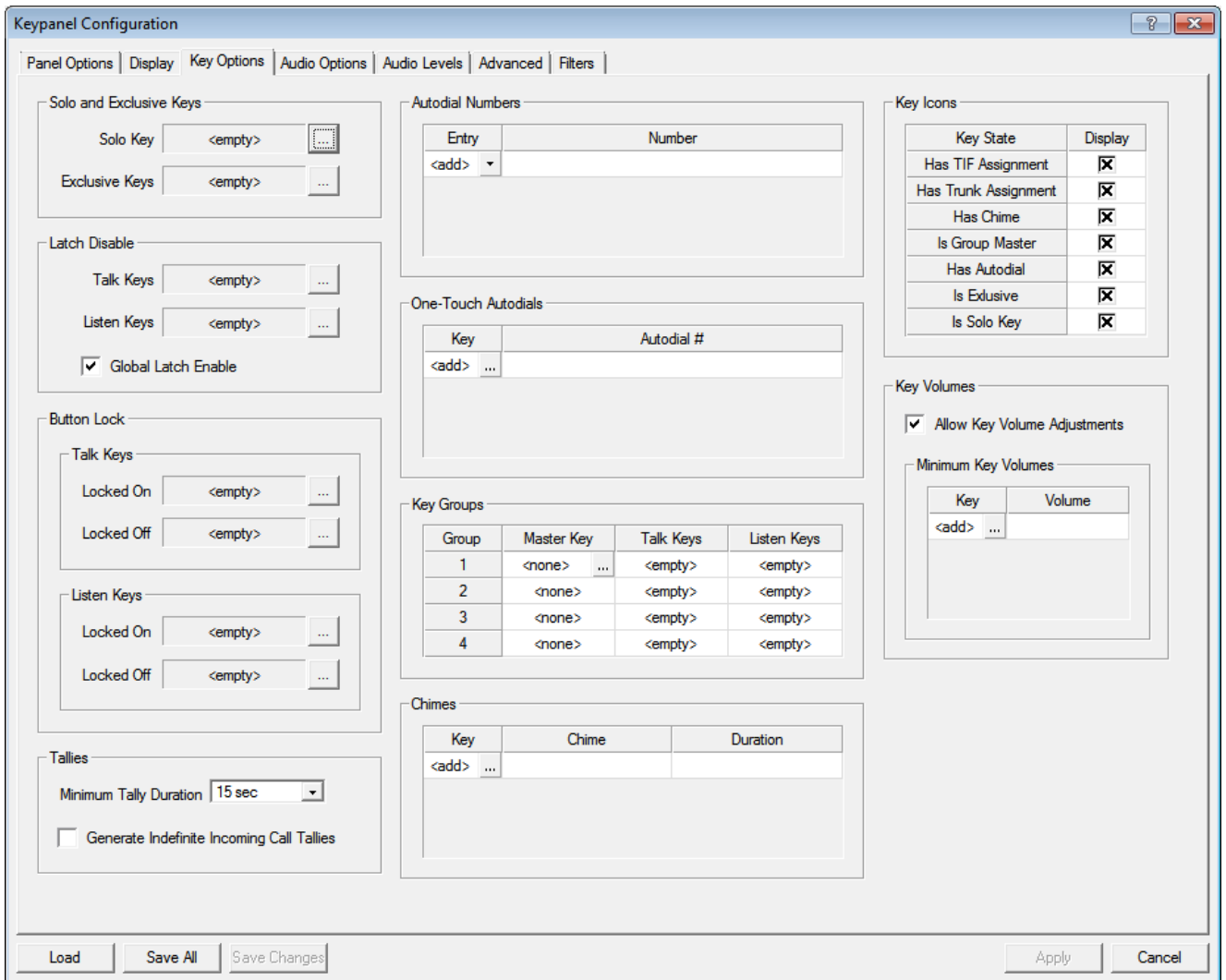

FIGURE 43. Keypanel Configuration – Key Options Page

Solo And Exclusive Keys Group Box

The **Solo and Exclusive Keys** group box is used to configure solo and exclusive keys. For a description of a solo key, see “Key Options Menu, Solo” on page 220. For a description of an exclusive key, see “Key Options Menu, Exclusive” on page 215.

NOTE: You can assign only one (1) solo key per keypanel.

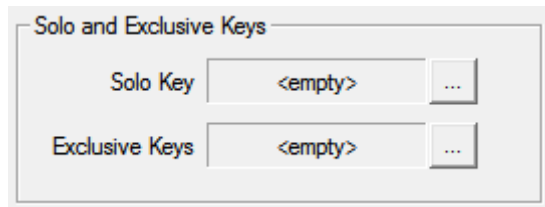



FIGURE 44. Key Options Page – Solo and Exclusive Keys Group Box

To **configure a solo key**, do the following:

1. Click the **Solo key browse button** .
The Key Selection window opens.

Row	Page	1	2	3	4	5	6	7	8	9	10	11	12	13	14
1	1	<input checked="" type="checkbox"/>	<input type="checkbox"/>	<input type="checkbox"/>	<input type="checkbox"/>	<input type="checkbox"/>	<input type="checkbox"/>	<input type="checkbox"/>	<input type="checkbox"/>	<input type="checkbox"/>	<input type="checkbox"/>	<input type="checkbox"/>	<input type="checkbox"/>	<input type="checkbox"/>	<input type="checkbox"/>
	2	<input type="checkbox"/>	<input type="checkbox"/>	<input type="checkbox"/>	<input type="checkbox"/>	<input type="checkbox"/>	<input type="checkbox"/>	<input type="checkbox"/>	<input type="checkbox"/>	<input type="checkbox"/>	<input type="checkbox"/>	<input type="checkbox"/>	<input type="checkbox"/>	<input type="checkbox"/>	<input type="checkbox"/>
	3	<input type="checkbox"/>	<input type="checkbox"/>	<input type="checkbox"/>	<input type="checkbox"/>	<input type="checkbox"/>	<input type="checkbox"/>	<input type="checkbox"/>	<input type="checkbox"/>	<input type="checkbox"/>	<input type="checkbox"/>	<input type="checkbox"/>	<input type="checkbox"/>	<input type="checkbox"/>	<input type="checkbox"/>
	4	<input type="checkbox"/>	<input type="checkbox"/>	<input type="checkbox"/>	<input type="checkbox"/>	<input type="checkbox"/>	<input type="checkbox"/>	<input type="checkbox"/>	<input type="checkbox"/>	<input type="checkbox"/>	<input type="checkbox"/>	<input type="checkbox"/>	<input type="checkbox"/>	<input type="checkbox"/>	<input type="checkbox"/>
	5	<input type="checkbox"/>	<input type="checkbox"/>	<input type="checkbox"/>	<input type="checkbox"/>	<input type="checkbox"/>	<input type="checkbox"/>	<input type="checkbox"/>	<input type="checkbox"/>	<input type="checkbox"/>	<input type="checkbox"/>	<input type="checkbox"/>	<input type="checkbox"/>	<input type="checkbox"/>	<input type="checkbox"/>
	6	<input type="checkbox"/>	<input type="checkbox"/>	<input type="checkbox"/>	<input type="checkbox"/>	<input type="checkbox"/>	<input type="checkbox"/>	<input type="checkbox"/>	<input type="checkbox"/>	<input type="checkbox"/>	<input type="checkbox"/>	<input type="checkbox"/>	<input type="checkbox"/>	<input type="checkbox"/>	<input type="checkbox"/>
	7	<input type="checkbox"/>	<input type="checkbox"/>	<input type="checkbox"/>	<input type="checkbox"/>	<input type="checkbox"/>	<input type="checkbox"/>	<input type="checkbox"/>	<input type="checkbox"/>	<input type="checkbox"/>	<input type="checkbox"/>	<input type="checkbox"/>	<input type="checkbox"/>	<input type="checkbox"/>	<input type="checkbox"/>
	8	<input type="checkbox"/>	<input type="checkbox"/>	<input type="checkbox"/>	<input type="checkbox"/>	<input type="checkbox"/>	<input type="checkbox"/>	<input type="checkbox"/>	<input type="checkbox"/>	<input type="checkbox"/>	<input type="checkbox"/>	<input type="checkbox"/>	<input type="checkbox"/>	<input type="checkbox"/>	<input type="checkbox"/>

2. Select the **check box** which correlates to the keypanel key and page you want to assign the solo key.
3. Click **OK**.
The Key Selection window closes and the key number appears in the Solo Key field.

To **configure the exclusive keys**, do the following:

1. Click the **Exclusive key browse button** .
The Key Selection window opens.

Row	Page	1	2	3	4	5	6	7	8	9	10	11	12	13	14	15
1	1	<input checked="" type="checkbox"/>	<input type="checkbox"/>	<input type="checkbox"/>	<input type="checkbox"/>	<input type="checkbox"/>	<input type="checkbox"/>	<input type="checkbox"/>	<input type="checkbox"/>	<input type="checkbox"/>	<input type="checkbox"/>	<input type="checkbox"/>	<input type="checkbox"/>	<input type="checkbox"/>	<input type="checkbox"/>	<input type="checkbox"/>
	2	<input type="checkbox"/>	<input type="checkbox"/>	<input type="checkbox"/>	<input type="checkbox"/>	<input type="checkbox"/>	<input type="checkbox"/>	<input type="checkbox"/>	<input type="checkbox"/>	<input type="checkbox"/>	<input type="checkbox"/>	<input type="checkbox"/>	<input type="checkbox"/>	<input type="checkbox"/>	<input type="checkbox"/>	<input type="checkbox"/>
	3	<input type="checkbox"/>	<input type="checkbox"/>	<input type="checkbox"/>	<input type="checkbox"/>	<input type="checkbox"/>	<input type="checkbox"/>	<input type="checkbox"/>	<input type="checkbox"/>	<input type="checkbox"/>	<input type="checkbox"/>	<input type="checkbox"/>	<input type="checkbox"/>	<input type="checkbox"/>	<input type="checkbox"/>	<input type="checkbox"/>
	4	<input type="checkbox"/>	<input type="checkbox"/>	<input type="checkbox"/>	<input type="checkbox"/>	<input type="checkbox"/>	<input type="checkbox"/>	<input type="checkbox"/>	<input type="checkbox"/>	<input type="checkbox"/>	<input type="checkbox"/>	<input type="checkbox"/>	<input type="checkbox"/>	<input type="checkbox"/>	<input type="checkbox"/>	<input type="checkbox"/>
	5	<input type="checkbox"/>	<input type="checkbox"/>	<input type="checkbox"/>	<input type="checkbox"/>	<input type="checkbox"/>	<input type="checkbox"/>	<input type="checkbox"/>	<input type="checkbox"/>	<input type="checkbox"/>	<input type="checkbox"/>	<input type="checkbox"/>	<input type="checkbox"/>	<input type="checkbox"/>	<input type="checkbox"/>	<input type="checkbox"/>
	6	<input type="checkbox"/>	<input type="checkbox"/>	<input type="checkbox"/>	<input type="checkbox"/>	<input type="checkbox"/>	<input type="checkbox"/>	<input type="checkbox"/>	<input type="checkbox"/>	<input type="checkbox"/>	<input type="checkbox"/>	<input type="checkbox"/>	<input type="checkbox"/>	<input type="checkbox"/>	<input type="checkbox"/>	<input type="checkbox"/>
	7	<input type="checkbox"/>	<input type="checkbox"/>	<input type="checkbox"/>	<input type="checkbox"/>	<input type="checkbox"/>	<input type="checkbox"/>	<input type="checkbox"/>	<input type="checkbox"/>	<input type="checkbox"/>	<input type="checkbox"/>	<input type="checkbox"/>	<input type="checkbox"/>	<input type="checkbox"/>	<input type="checkbox"/>	<input type="checkbox"/>
	8	<input type="checkbox"/>	<input type="checkbox"/>	<input type="checkbox"/>	<input type="checkbox"/>	<input type="checkbox"/>	<input type="checkbox"/>	<input type="checkbox"/>	<input type="checkbox"/>	<input type="checkbox"/>	<input type="checkbox"/>	<input type="checkbox"/>	<input type="checkbox"/>	<input type="checkbox"/>	<input type="checkbox"/>	<input type="checkbox"/>

2. Select the **check boxes** which correlate to the keypad keys and pages you want to assign an exclusive key.
3. Click **OK**.
The Key Selection window closes and the key number appears in the Solo Key field.

Latch Disable Group Box

The **Latch Disable** group box is used to enable or disable the keypanel key to stay on when pressed. For more information, see “Key Options Menu, Latching” on page 217.

NOTE: A key only latches if it is pressed and released within 0.5 seconds. Otherwise, the key always turns off when released.

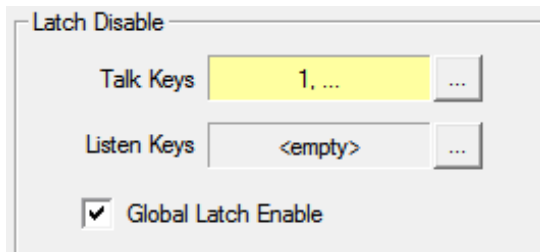



FIGURE 45. Key Options Page – Latch Disable Group Box

To **latch disable specific talk and listen keys**, do the following:

1. Click either the **Talk or Listen browse button** . *The Key Selection window appears.*
2. Select the **key** you want to latch disable.
3. Click **OK**.

To **latch enable or disable all keys (global latch enable)**, do the following:

- > Select the **Global Latch Enable check box**.
OR
Clear the **Global Latch Enable check box** to globally disable latching.

Button Lock Group Box

The **Button Lock** group box is used to lock talk and/or listen keys in the on or off position. Each key may be independently locked on or off.

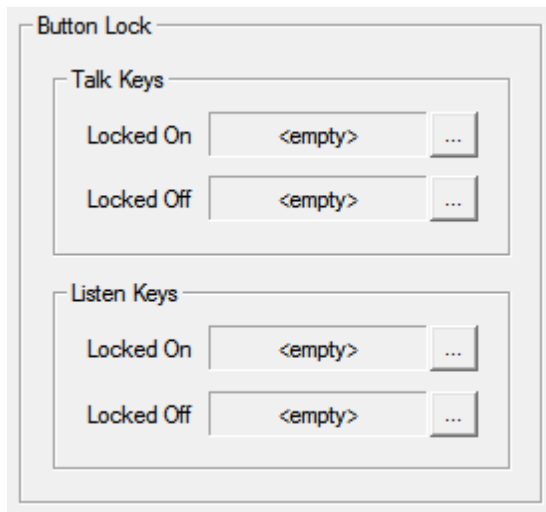



FIGURE 46. Key Options Page – Button Lock Group Box

To **configure button lock on or off for talk keys**, do the following:

- From the talk keys group box, click the **browse button** for Locked On .
OR
Click the **browse button** for Locked Off.
The Key Selection window opens.

Row	Page	1	2	3	4	5	6	7	8	9	10	11	12	13	14
1	1	<input checked="" type="checkbox"/>	<input type="checkbox"/>	<input type="checkbox"/>	<input type="checkbox"/>	<input type="checkbox"/>	<input type="checkbox"/>	<input type="checkbox"/>	<input type="checkbox"/>	<input type="checkbox"/>	<input type="checkbox"/>	<input type="checkbox"/>	<input type="checkbox"/>	<input type="checkbox"/>	<input type="checkbox"/>
	2	<input type="checkbox"/>	<input type="checkbox"/>	<input type="checkbox"/>	<input type="checkbox"/>	<input type="checkbox"/>	<input type="checkbox"/>	<input type="checkbox"/>	<input type="checkbox"/>	<input type="checkbox"/>	<input type="checkbox"/>	<input type="checkbox"/>	<input type="checkbox"/>	<input type="checkbox"/>	<input type="checkbox"/>
	3	<input type="checkbox"/>	<input type="checkbox"/>	<input type="checkbox"/>	<input type="checkbox"/>	<input type="checkbox"/>	<input type="checkbox"/>	<input type="checkbox"/>	<input type="checkbox"/>	<input type="checkbox"/>	<input type="checkbox"/>	<input type="checkbox"/>	<input type="checkbox"/>	<input type="checkbox"/>	<input type="checkbox"/>
	4	<input type="checkbox"/>	<input type="checkbox"/>	<input type="checkbox"/>	<input type="checkbox"/>	<input type="checkbox"/>	<input type="checkbox"/>	<input type="checkbox"/>	<input type="checkbox"/>	<input type="checkbox"/>	<input type="checkbox"/>	<input type="checkbox"/>	<input type="checkbox"/>	<input type="checkbox"/>	<input type="checkbox"/>
	5	<input type="checkbox"/>	<input type="checkbox"/>	<input type="checkbox"/>	<input type="checkbox"/>	<input type="checkbox"/>	<input type="checkbox"/>	<input type="checkbox"/>	<input type="checkbox"/>	<input type="checkbox"/>	<input type="checkbox"/>	<input type="checkbox"/>	<input type="checkbox"/>	<input type="checkbox"/>	<input type="checkbox"/>
	6	<input type="checkbox"/>	<input type="checkbox"/>	<input type="checkbox"/>	<input type="checkbox"/>	<input type="checkbox"/>	<input type="checkbox"/>	<input type="checkbox"/>	<input type="checkbox"/>	<input type="checkbox"/>	<input type="checkbox"/>	<input type="checkbox"/>	<input type="checkbox"/>	<input type="checkbox"/>	<input type="checkbox"/>
	7	<input type="checkbox"/>	<input type="checkbox"/>	<input type="checkbox"/>	<input type="checkbox"/>	<input type="checkbox"/>	<input type="checkbox"/>	<input type="checkbox"/>	<input type="checkbox"/>	<input type="checkbox"/>	<input type="checkbox"/>	<input type="checkbox"/>	<input type="checkbox"/>	<input type="checkbox"/>	<input type="checkbox"/>
	8	<input type="checkbox"/>	<input type="checkbox"/>	<input type="checkbox"/>	<input type="checkbox"/>	<input type="checkbox"/>	<input type="checkbox"/>	<input type="checkbox"/>	<input type="checkbox"/>	<input type="checkbox"/>	<input type="checkbox"/>	<input type="checkbox"/>	<input type="checkbox"/>	<input type="checkbox"/>	<input type="checkbox"/>

- Select the **check boxes** of all the talk keys you want to configure as Locked On.
OR
Select the **check boxes** of all the talk keys you want configure as Locked Off.
- Click **OK**.
The Key Selection window closes.

To **configure button lock on or off for listen keys**, do the following:

- From the listen keys group box, click the **browse button** for Locked On .
OR
Click the **browse button** for Locked Off.
The Key Selection window opens.

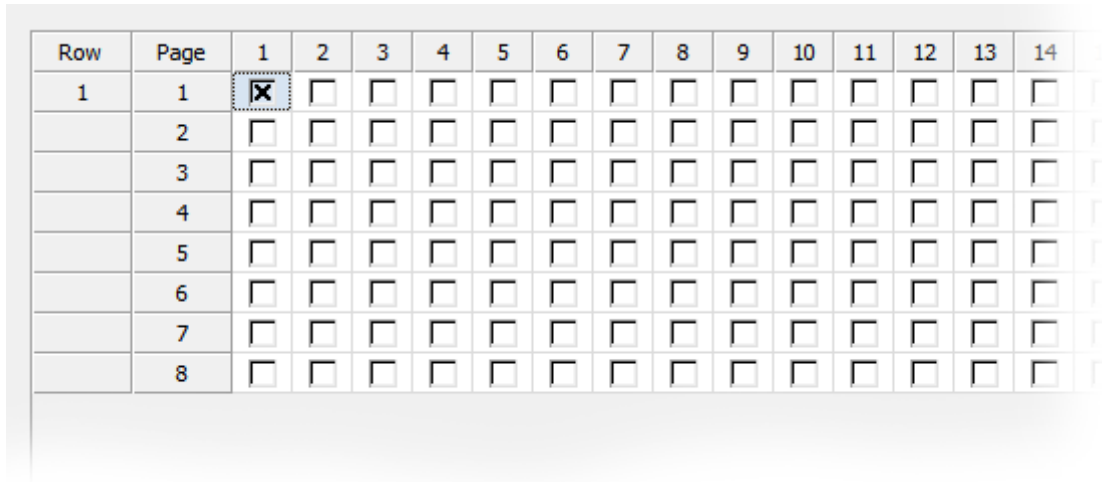

Row	Page	1	2	3	4	5	6	7	8	9	10	11	12	13	14
1	1	<input checked="" type="checkbox"/>	<input type="checkbox"/>	<input type="checkbox"/>	<input type="checkbox"/>	<input type="checkbox"/>	<input type="checkbox"/>	<input type="checkbox"/>	<input type="checkbox"/>	<input type="checkbox"/>	<input type="checkbox"/>	<input type="checkbox"/>	<input type="checkbox"/>	<input type="checkbox"/>	<input type="checkbox"/>
	2	<input type="checkbox"/>	<input type="checkbox"/>	<input type="checkbox"/>	<input type="checkbox"/>	<input type="checkbox"/>	<input type="checkbox"/>	<input type="checkbox"/>	<input type="checkbox"/>	<input type="checkbox"/>	<input type="checkbox"/>	<input type="checkbox"/>	<input type="checkbox"/>	<input type="checkbox"/>	<input type="checkbox"/>
	3	<input type="checkbox"/>	<input type="checkbox"/>	<input type="checkbox"/>	<input type="checkbox"/>	<input type="checkbox"/>	<input type="checkbox"/>	<input type="checkbox"/>	<input type="checkbox"/>	<input type="checkbox"/>	<input type="checkbox"/>	<input type="checkbox"/>	<input type="checkbox"/>	<input type="checkbox"/>	<input type="checkbox"/>
	4	<input type="checkbox"/>	<input type="checkbox"/>	<input type="checkbox"/>	<input type="checkbox"/>	<input type="checkbox"/>	<input type="checkbox"/>	<input type="checkbox"/>	<input type="checkbox"/>	<input type="checkbox"/>	<input type="checkbox"/>	<input type="checkbox"/>	<input type="checkbox"/>	<input type="checkbox"/>	<input type="checkbox"/>
	5	<input type="checkbox"/>	<input type="checkbox"/>	<input type="checkbox"/>	<input type="checkbox"/>	<input type="checkbox"/>	<input type="checkbox"/>	<input type="checkbox"/>	<input type="checkbox"/>	<input type="checkbox"/>	<input type="checkbox"/>	<input type="checkbox"/>	<input type="checkbox"/>	<input type="checkbox"/>	<input type="checkbox"/>
	6	<input type="checkbox"/>	<input type="checkbox"/>	<input type="checkbox"/>	<input type="checkbox"/>	<input type="checkbox"/>	<input type="checkbox"/>	<input type="checkbox"/>	<input type="checkbox"/>	<input type="checkbox"/>	<input type="checkbox"/>	<input type="checkbox"/>	<input type="checkbox"/>	<input type="checkbox"/>	<input type="checkbox"/>
	7	<input type="checkbox"/>	<input type="checkbox"/>	<input type="checkbox"/>	<input type="checkbox"/>	<input type="checkbox"/>	<input type="checkbox"/>	<input type="checkbox"/>	<input type="checkbox"/>	<input type="checkbox"/>	<input type="checkbox"/>	<input type="checkbox"/>	<input type="checkbox"/>	<input type="checkbox"/>	<input type="checkbox"/>
	8	<input type="checkbox"/>	<input type="checkbox"/>	<input type="checkbox"/>	<input type="checkbox"/>	<input type="checkbox"/>	<input type="checkbox"/>	<input type="checkbox"/>	<input type="checkbox"/>	<input type="checkbox"/>	<input type="checkbox"/>	<input type="checkbox"/>	<input type="checkbox"/>	<input type="checkbox"/>	<input type="checkbox"/>

- Select the **check boxes** of all the listen keys you want to configure as Locked On.
OR
Select the **check boxes** of all the listen keys you want configure as Locked Off.
- Click **OK**.
The Key Selection window closes.

Tallies Group Box

The **Tallies** group box is used to set the amount a time a blinking tally displays. For more information about Tallies, see “Key Options Menu, Tallies” on page 221.

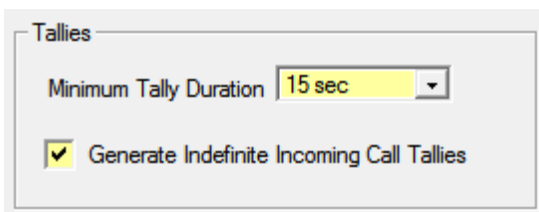

FIGURE 47. Key Options Page – Tallies Group Box

To **configure tally times**, do the following:

- > From the Minimum Tally Duration drop down menu, select the **duration of time** you desire.

To **generate indefinite call tallies**, do the following:

- Select the **Generate Indefinite Incoming Call Tallies check box** to set indefinite tallies for all calls.

Autodial Numbers Group Box

The **Autodial Numbers** group box is used to configure up to 100 autodial numbers. **Autodial** stores commonly used phone numbers in the auto dial list locally on the keypad.

You can also create a centralized auto dial list which is stored on the Master Controller and maintained through AZedit. For more information, see “Centralized Auto Dials” on page 247 .

Entry	Number
1	18005551212
<add>	
2	
3	
4	
5	
6	
7	
8	
9	
10	
11	
12	
13	
14	
15	
16	
17	

FIGURE 48. Key Options Page – Autodial Numbers Group Box

To **add autodial numbers**, do the following:

1. From the Entry column drop down list, select the **entry number** for your autodial number. This number does not have to follow sequence.
2. In the Number column field, enter the **number** you want to assign as an autodial.

NOTE: No spaces or dashes are allowed in the number entry field.

One-Touch Autodials Group Box

The **One-Touch Autodials** group box is used to assign autodial numbers to specific keypanel keys. One-Touch Auto Dials are configured using the locally stored numbers on the keypanel. Once a 1-Touch Auto Dial key is configured, pressing the configured key causes the TIF to go off-hook and auto dial the selected number.

IMPORTANT: You must have existing autodial numbers before assigning them to a keypanel key. See “Autodial Numbers Group Box” on page 119.

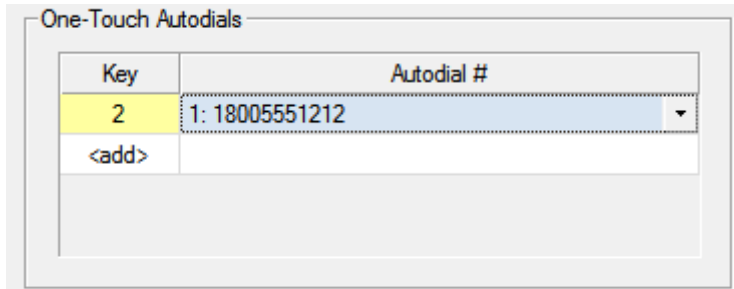

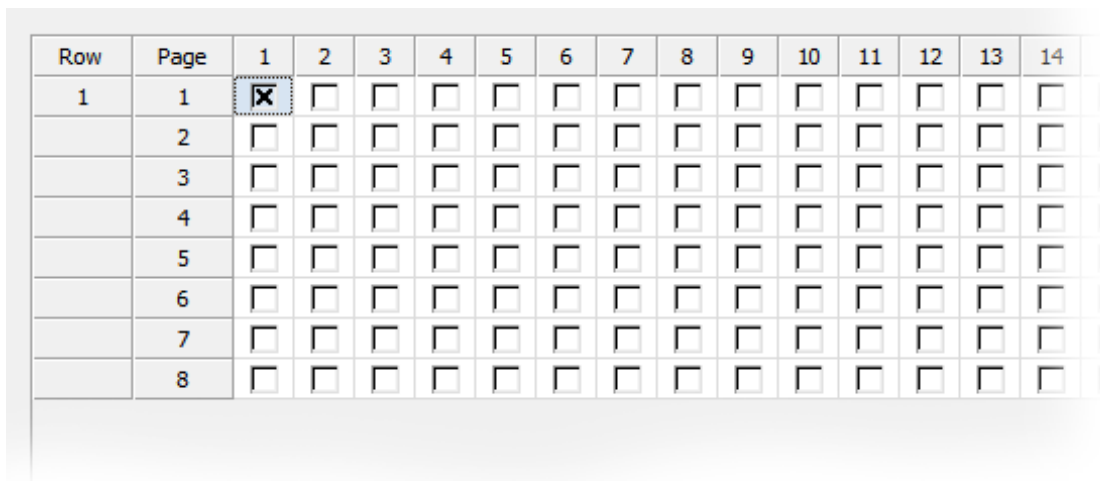

FIGURE 49. Key Options Page – One-Touch Autodials Group Box

To **add an autodial number**, do the following:

1. In the Key column field, click the **browse button** .
The Key Selection window appears.



2. Select the **key (or keys)** you want to assign autodial.
3. Click **OK**.
The Key Selection window closes.
4. From the Autodial # column drop down menu, select the **number** you want to assign to the key.

Key Groups Group Box

The **Key Groups** group box is used to set up key groups. A key group allows a user to activate a group of keys by activating one (1) key (the master key). When the master key is activated, all keys in the group become active.

You can create *up to four (4) key groups*.

Key Groups			
Group	Master Key	Talk Keys	Listen Keys
1	1	4, 5, 6	2, 11, 12, 13, ...
2	<none>	<empty>	<empty>
3	<none>	<empty>	<empty>
4	<none>	<empty>	<empty>

FIGURE 50. Key Options Page – Key Groups Group Box

To **create a key group**, do the following:

- In the Master Key column, click the **browse button** .
The Key Selection window appears.

Row	Page	1	2	3	4	5	6	7	8	9	10	11	12	13	14
1	1	<input checked="" type="checkbox"/>	<input type="checkbox"/>	<input type="checkbox"/>	<input type="checkbox"/>	<input type="checkbox"/>	<input type="checkbox"/>	<input type="checkbox"/>	<input type="checkbox"/>	<input type="checkbox"/>	<input type="checkbox"/>	<input type="checkbox"/>	<input type="checkbox"/>	<input type="checkbox"/>	<input type="checkbox"/>
	2	<input type="checkbox"/>	<input type="checkbox"/>	<input type="checkbox"/>	<input type="checkbox"/>	<input type="checkbox"/>	<input type="checkbox"/>	<input type="checkbox"/>	<input type="checkbox"/>	<input type="checkbox"/>	<input type="checkbox"/>	<input type="checkbox"/>	<input type="checkbox"/>	<input type="checkbox"/>	<input type="checkbox"/>
	3	<input type="checkbox"/>	<input type="checkbox"/>	<input type="checkbox"/>	<input type="checkbox"/>	<input type="checkbox"/>	<input type="checkbox"/>	<input type="checkbox"/>	<input type="checkbox"/>	<input type="checkbox"/>	<input type="checkbox"/>	<input type="checkbox"/>	<input type="checkbox"/>	<input type="checkbox"/>	<input type="checkbox"/>
	4	<input type="checkbox"/>	<input type="checkbox"/>	<input type="checkbox"/>	<input type="checkbox"/>	<input type="checkbox"/>	<input type="checkbox"/>	<input type="checkbox"/>	<input type="checkbox"/>	<input type="checkbox"/>	<input type="checkbox"/>	<input type="checkbox"/>	<input type="checkbox"/>	<input type="checkbox"/>	<input type="checkbox"/>
	5	<input type="checkbox"/>	<input type="checkbox"/>	<input type="checkbox"/>	<input type="checkbox"/>	<input type="checkbox"/>	<input type="checkbox"/>	<input type="checkbox"/>	<input type="checkbox"/>	<input type="checkbox"/>	<input type="checkbox"/>	<input type="checkbox"/>	<input type="checkbox"/>	<input type="checkbox"/>	<input type="checkbox"/>
	6	<input type="checkbox"/>	<input type="checkbox"/>	<input type="checkbox"/>	<input type="checkbox"/>	<input type="checkbox"/>	<input type="checkbox"/>	<input type="checkbox"/>	<input type="checkbox"/>	<input type="checkbox"/>	<input type="checkbox"/>	<input type="checkbox"/>	<input type="checkbox"/>	<input type="checkbox"/>	<input type="checkbox"/>
	7	<input type="checkbox"/>	<input type="checkbox"/>	<input type="checkbox"/>	<input type="checkbox"/>	<input type="checkbox"/>	<input type="checkbox"/>	<input type="checkbox"/>	<input type="checkbox"/>	<input type="checkbox"/>	<input type="checkbox"/>	<input type="checkbox"/>	<input type="checkbox"/>	<input type="checkbox"/>	<input type="checkbox"/>
	8	<input type="checkbox"/>	<input type="checkbox"/>	<input type="checkbox"/>	<input type="checkbox"/>	<input type="checkbox"/>	<input type="checkbox"/>	<input type="checkbox"/>	<input type="checkbox"/>	<input type="checkbox"/>	<input type="checkbox"/>	<input type="checkbox"/>	<input type="checkbox"/>	<input type="checkbox"/>	<input type="checkbox"/>

- Select the **keypanel key check box** you want to set as the Master key.

NOTE: Only one (1) key can be a master key.

- Click **OK**.
The Key Selection window closes.
- From the Talk Keys column, select the **browse button**.
The Key Selection window appears.
- Select the **check boxes** of all the talk keys you want to assign as slave keys.
- From the Listen Keys column, select the **browse button**.
The Key Selection window appears.
- Select the **check boxes** of all the listen keys you want to assign as slave keys.

Chimes Group Box

The **Chimes** group box is used to configure a chime tone to sound on incoming call announcements for selected keypanel keys. You can configure the chime tone to activate for a specified amount of time after a call is received. For more information on chimes, see “Key Options Menu, Chime” on page 214.

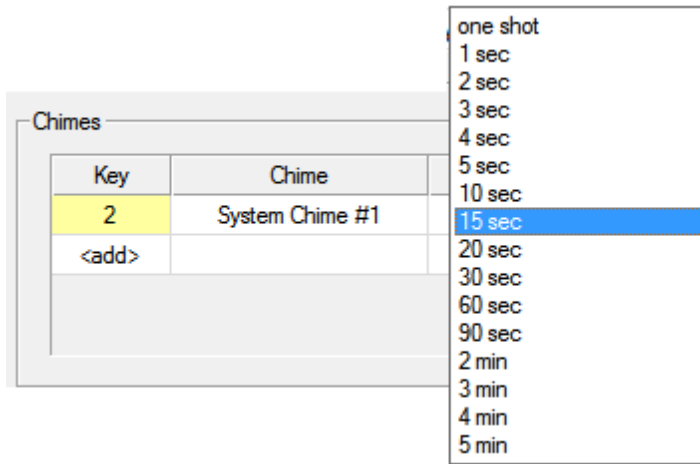



FIGURE 51. Key Options Page – Chimes Group Box

To **configure a chime notification**, do the following:

1. Click the **Key browse button** .
The Key Selection window opens.

Row	Page	1	2	3	4	5	6	7	8	9	10	11	12	13	14
1	1	<input checked="" type="checkbox"/>	<input type="checkbox"/>	<input type="checkbox"/>	<input type="checkbox"/>	<input type="checkbox"/>	<input type="checkbox"/>	<input type="checkbox"/>	<input type="checkbox"/>	<input type="checkbox"/>	<input type="checkbox"/>	<input type="checkbox"/>	<input type="checkbox"/>	<input type="checkbox"/>	<input type="checkbox"/>
	2	<input type="checkbox"/>	<input type="checkbox"/>	<input type="checkbox"/>	<input type="checkbox"/>	<input type="checkbox"/>	<input type="checkbox"/>	<input type="checkbox"/>	<input type="checkbox"/>	<input type="checkbox"/>	<input type="checkbox"/>	<input type="checkbox"/>	<input type="checkbox"/>	<input type="checkbox"/>	<input type="checkbox"/>
	3	<input type="checkbox"/>	<input type="checkbox"/>	<input type="checkbox"/>	<input type="checkbox"/>	<input type="checkbox"/>	<input type="checkbox"/>	<input type="checkbox"/>	<input type="checkbox"/>	<input type="checkbox"/>	<input type="checkbox"/>	<input type="checkbox"/>	<input type="checkbox"/>	<input type="checkbox"/>	<input type="checkbox"/>
	4	<input type="checkbox"/>	<input type="checkbox"/>	<input type="checkbox"/>	<input type="checkbox"/>	<input type="checkbox"/>	<input type="checkbox"/>	<input type="checkbox"/>	<input type="checkbox"/>	<input type="checkbox"/>	<input type="checkbox"/>	<input type="checkbox"/>	<input type="checkbox"/>	<input type="checkbox"/>	<input type="checkbox"/>
	5	<input type="checkbox"/>	<input type="checkbox"/>	<input type="checkbox"/>	<input type="checkbox"/>	<input type="checkbox"/>	<input type="checkbox"/>	<input type="checkbox"/>	<input type="checkbox"/>	<input type="checkbox"/>	<input type="checkbox"/>	<input type="checkbox"/>	<input type="checkbox"/>	<input type="checkbox"/>	<input type="checkbox"/>
	6	<input type="checkbox"/>	<input type="checkbox"/>	<input type="checkbox"/>	<input type="checkbox"/>	<input type="checkbox"/>	<input type="checkbox"/>	<input type="checkbox"/>	<input type="checkbox"/>	<input type="checkbox"/>	<input type="checkbox"/>	<input type="checkbox"/>	<input type="checkbox"/>	<input type="checkbox"/>	<input type="checkbox"/>
	7	<input type="checkbox"/>	<input type="checkbox"/>	<input type="checkbox"/>	<input type="checkbox"/>	<input type="checkbox"/>	<input type="checkbox"/>	<input type="checkbox"/>	<input type="checkbox"/>	<input type="checkbox"/>	<input type="checkbox"/>	<input type="checkbox"/>	<input type="checkbox"/>	<input type="checkbox"/>	<input type="checkbox"/>
	8	<input type="checkbox"/>	<input type="checkbox"/>	<input type="checkbox"/>	<input type="checkbox"/>	<input type="checkbox"/>	<input type="checkbox"/>	<input type="checkbox"/>	<input type="checkbox"/>	<input type="checkbox"/>	<input type="checkbox"/>	<input type="checkbox"/>	<input type="checkbox"/>	<input type="checkbox"/>	<input type="checkbox"/>

2. Select the **key** you want to assign the chime notification.
3. Click **OK**.
The Key Selection window closes and the key number appears in the field.
4. From the Chime column drop down menu, select the **chime** you want to assign.
5. From the Duration column drop down menu, select the **duration** the chime notification should last.

Key Icons Group Box

The **Key Icons** group box is used to determine which key states will display an icon to visually represent their assigned state.

For more information, see “Key Options Menu, Icons” on page 216.

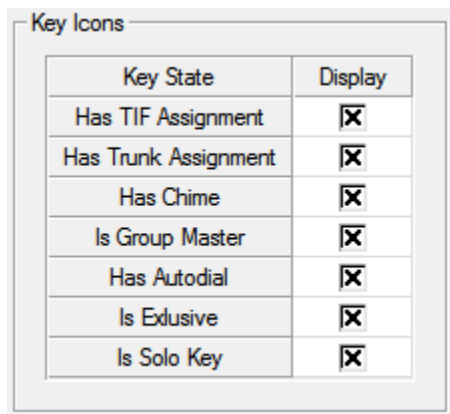

FIGURE 52. Key Options Page – Key Icons Group Box

To **enable key icons**, do the following:

6. In the Display column, select the **check box** next to the key state you want to display an icon.

Key Volumes Group Box.

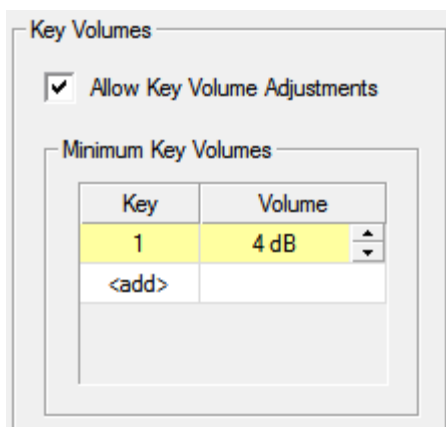

FIGURE 53. Key Options Page – Key Volumes Group Box

Allow Key Volume Adjustments Check Box

The **Allow Key Volume Adjustments** check box is used to globally enable or disable key volume adjustments.

To **enable key volume adjustments**, do the following:

- > Select the **Allow Key Volume Adjustments check box**.

Minimum Key Volumes Table

The **Minimum Key Volumes** table is used to adjust minimum volumes for each key on the keypanel.

To **adjust minimum volumes**, do the following:

1. In the Key column field, click the **browse button** .
The Key Selection window appears.

Row	Page	1	2	3	4	5	6	7	8	9	10	11	12	13	14
1	1	<input checked="" type="checkbox"/>	<input type="checkbox"/>	<input type="checkbox"/>	<input type="checkbox"/>	<input type="checkbox"/>	<input type="checkbox"/>	<input type="checkbox"/>	<input type="checkbox"/>	<input type="checkbox"/>	<input type="checkbox"/>	<input type="checkbox"/>	<input type="checkbox"/>	<input type="checkbox"/>	<input type="checkbox"/>
	2	<input type="checkbox"/>	<input type="checkbox"/>	<input type="checkbox"/>	<input type="checkbox"/>	<input type="checkbox"/>	<input type="checkbox"/>	<input type="checkbox"/>	<input type="checkbox"/>	<input type="checkbox"/>	<input type="checkbox"/>	<input type="checkbox"/>	<input type="checkbox"/>	<input type="checkbox"/>	<input type="checkbox"/>
	3	<input type="checkbox"/>	<input type="checkbox"/>	<input type="checkbox"/>	<input type="checkbox"/>	<input type="checkbox"/>	<input type="checkbox"/>	<input type="checkbox"/>	<input type="checkbox"/>	<input type="checkbox"/>	<input type="checkbox"/>	<input type="checkbox"/>	<input type="checkbox"/>	<input type="checkbox"/>	<input type="checkbox"/>
	4	<input type="checkbox"/>	<input type="checkbox"/>	<input type="checkbox"/>	<input type="checkbox"/>	<input type="checkbox"/>	<input type="checkbox"/>	<input type="checkbox"/>	<input type="checkbox"/>	<input type="checkbox"/>	<input type="checkbox"/>	<input type="checkbox"/>	<input type="checkbox"/>	<input type="checkbox"/>	<input type="checkbox"/>
	5	<input type="checkbox"/>	<input type="checkbox"/>	<input type="checkbox"/>	<input type="checkbox"/>	<input type="checkbox"/>	<input type="checkbox"/>	<input type="checkbox"/>	<input type="checkbox"/>	<input type="checkbox"/>	<input type="checkbox"/>	<input type="checkbox"/>	<input type="checkbox"/>	<input type="checkbox"/>	<input type="checkbox"/>
	6	<input type="checkbox"/>	<input type="checkbox"/>	<input type="checkbox"/>	<input type="checkbox"/>	<input type="checkbox"/>	<input type="checkbox"/>	<input type="checkbox"/>	<input type="checkbox"/>	<input type="checkbox"/>	<input type="checkbox"/>	<input type="checkbox"/>	<input type="checkbox"/>	<input type="checkbox"/>	<input type="checkbox"/>
	7	<input type="checkbox"/>	<input type="checkbox"/>	<input type="checkbox"/>	<input type="checkbox"/>	<input type="checkbox"/>	<input type="checkbox"/>	<input type="checkbox"/>	<input type="checkbox"/>	<input type="checkbox"/>	<input type="checkbox"/>	<input type="checkbox"/>	<input type="checkbox"/>	<input type="checkbox"/>	<input type="checkbox"/>
	8	<input type="checkbox"/>	<input type="checkbox"/>	<input type="checkbox"/>	<input type="checkbox"/>	<input type="checkbox"/>	<input type="checkbox"/>	<input type="checkbox"/>	<input type="checkbox"/>	<input type="checkbox"/>	<input type="checkbox"/>	<input type="checkbox"/>	<input type="checkbox"/>	<input type="checkbox"/>	<input type="checkbox"/>

2. Select the **key** you want to adjust.
3. Click **OK**.
The Key Selection window closes.
4. Using the Volume column spin box, adjust the **minimum volume** of the key.

Audio Options Page

IMPORTANT: OMNEO 3 through OMNEO 8 only appear when the Audio Package is purchased, otherwise, they do not display.

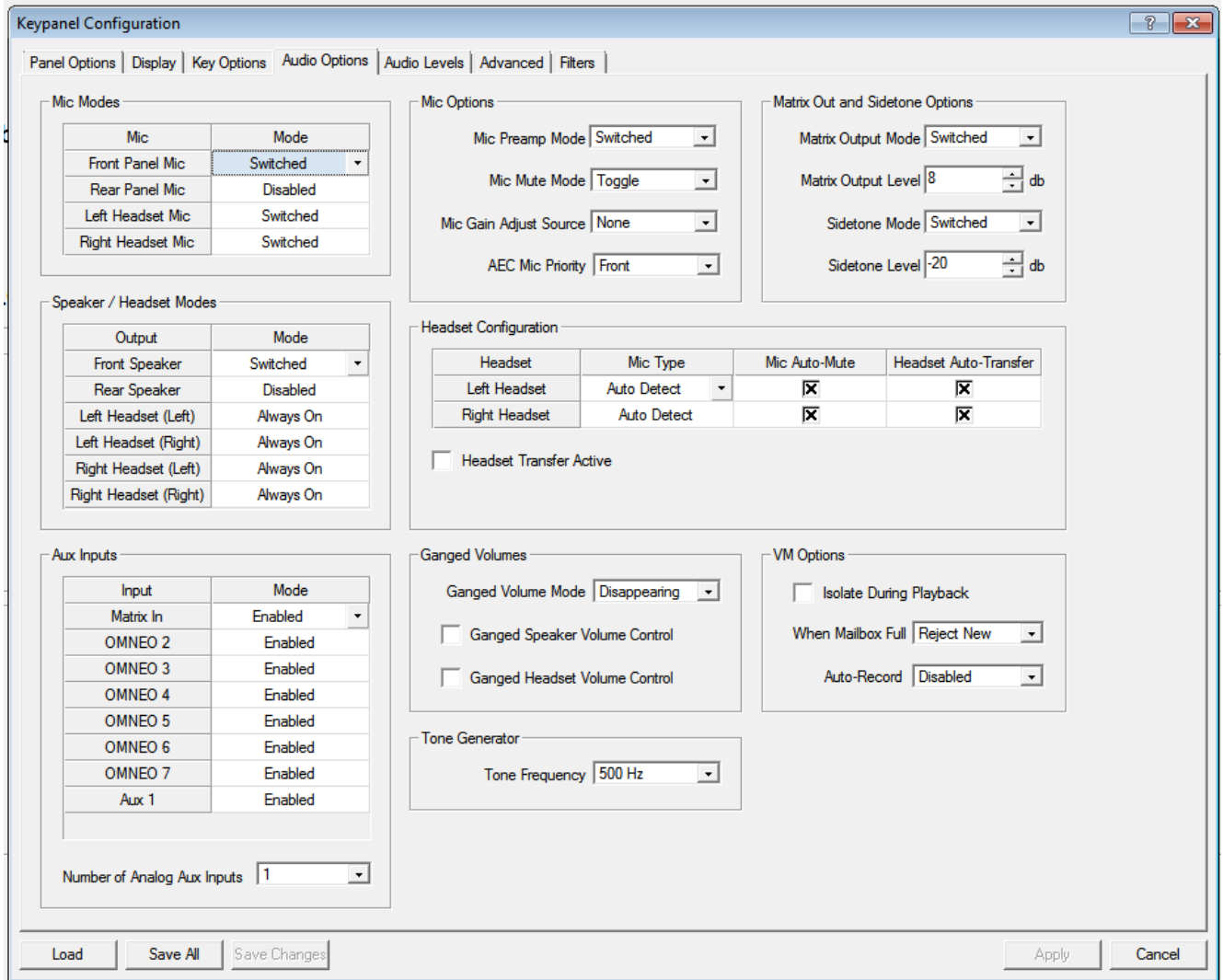

FIGURE 54. Keypanel Configuration – Audio Options

Mic Modes Group Box

The **Mic Modes** group box is used to configure panel mics and headset mics.

Available options for this group box are:

Disabled

Enabled

Switched When set to Switched mode, the state of the Panel Mic is controlled by the Mic Sel key.

The default for the Rear Panel Mic is *disabled*, while the default for the Front Panel Mic is *switched*.

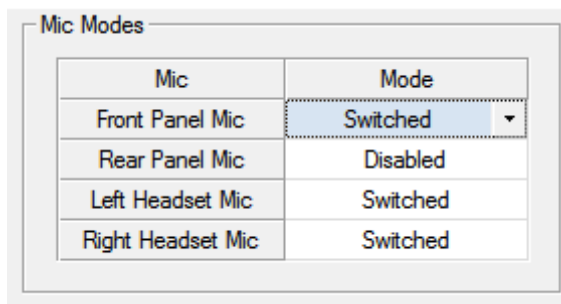

FIGURE 55. Audio Options Page – Mic Modes Group Box

To **configure the mic mode**, do the following:

- > From the Mode column drop down list, select the **mode** for the microphone you want to configure.

Speaker / Headset Modes Group Box

The **Speaker / Headset Modes** group box is used to configure the way the speakers or headsets act.

For more information, see, “Audio Options Menu, Speaker” on page 200 or “Audio Options Menu, Headset Mic” on page 192.

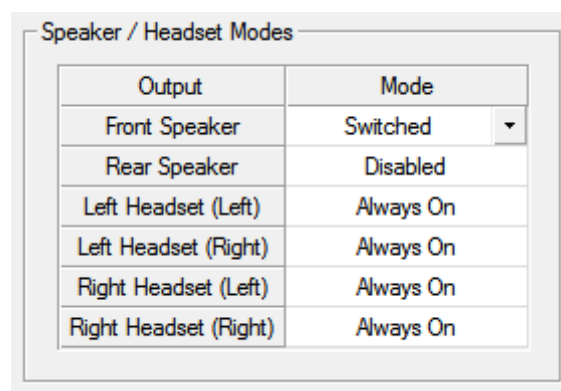

FIGURE 56. Audio Options Page – Speaker / Headset Modes Group Box

To **configure speaker/headset modes**, do the following:

- > From the Mode column drop down menu, select the **mode for the output desired**.

Aux Inputs Group Box

The **Aux Inputs** group box is used to enable or disable the volume control for audio inputs through the front panel encoder. For more information, see “Audio Options Menu, Inputs” on page 195.

IMPORTANT: OMNEO 3 through OMNEO 8 only appear when the Audio Package is purchased, otherwise, they do not display.

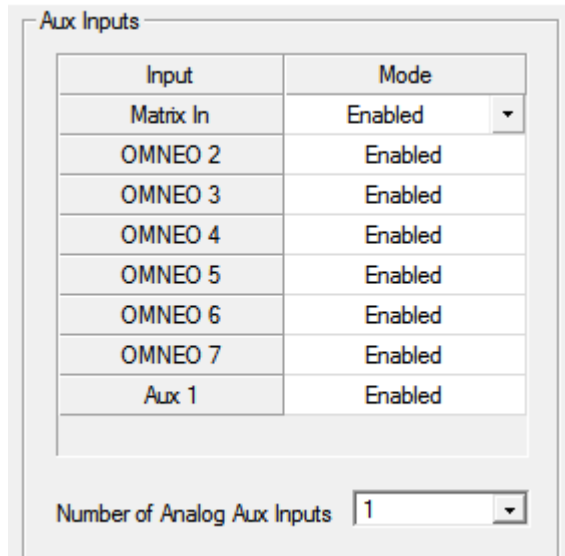

FIGURE 57. Audio Options Page – Aux Inputs Group Box

Input Display Column

The **Input Display** column displays the available inputs that can be enabled or disabled.

Mode Drop Down Menu Column

The **Mode** drop down column is used to enable and disable the Aux Inputs.

NOTE: OMNEO 4, 6, 8 have the ganged option. You can gang OMNEO 3+4, 5+7, 6, and 7+8

To **enable or disable volume control for an input**, do the following:

- > From the Mode column drop down menu, select **Enabled** or **Disabled** next to the desired input.

Number of Analog Aux Inputs Drop Down Menu

The **Number of Analog Aux Inputs** drop down menu is used to select the number of auxiliary inputs on the keypad when the panel has been licensed for OMNEO 3-8.

When the keypad is licensed for OMNEO 3–8, OMNEO 8 and Aux 1 are multiplexed, meaning you can have one or the other, but not both. The same rule applies to OMNEO 7 and Aux 2; both are muxed and both cannot be used together. Also, you cannot have Aux 2 without Aux 1.

The options available for the OMNEO 3–8:

- Number of Analog Aux = 2, OMNEO 1-6, plus Aux 1-2
- Number of Analog Aux = 1, OMNEO 1-7, plus Aux 1
- Number of Analog Aux = 0, OMNEO 1-8

When a keypad is not licensed with the Audio Package, meaning it only has OMNEO 1 and 2, then the number of analog aux inputs is the maximum supported by the panel:

- KP-5032/4016 - Maximum number of Analog Aux = 2, OMNEO 1-2, plus Aux 1-2
- DKP-4016 - Maximum number of Analog Aux = 1, OMNEO 1-2, plus Aux 1
- KP-3016- Maximum number of Analog Aux = 0, OMNEO 1-2
- KP-3016A does not support OMNEO

When changes are made, such as the number of analog aux inputs is changed from 0 to 1, the changes are available but are not displayed until you have exited and reloaded the window.

Mic Options Group Box

The **Mic Options** group box is used to choose how audio is routed to the Preamp Output connector, configure the actions of the Mic Mute key, to enable or disable mic gain on the keypanel, and to configure AEC¹ (Acoustic Echo Cancellation) prioritization on a microphone.

- For further explanation of the available selections for the Mic Preamp Mode drop down menu, see “Audio Options Menu, Preamp Out” on page 199.
- For further explanation of the available selections for the Mic Mute Mode drop down menu, see “Audio Options Menu, Mic Mute” on page 198.
- For further explanation of the available selections for the Mic Gain Adjust Source drop down menu, see “Audio Options Menu, Mic Gain” on page 197.
- For further explanation of the available selection for the AEC Mic Priority drop down menu, see “AEC” on page 178.

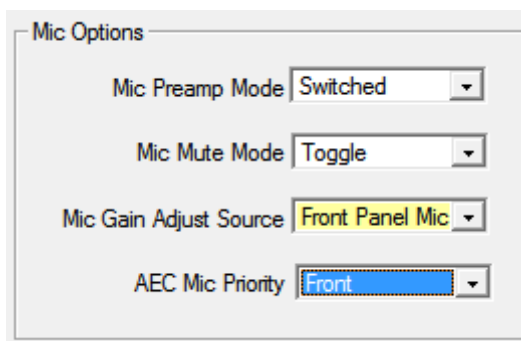

FIGURE 58. Audio Options Page – Mic Options Group Box

To **configure mic options**, do the following:

1. From the Mic Preamp Mode drop down menu, select **Switched**, **Hot**, **Disabled**, or **Inverted**.
2. From the Mic Mute Mode drop down menu, select **Disabled**, **Toggle**, or **Momentary**.
3. From the Mic Gain Adjust Source drop down menu, select the **mic gain adjust source**.
4. From the AEC Mic Priority drop down menu, select **front** or **rear**.

1. AEC is used to prevent feedback from occurring between the microphone and the speaker.

Matrix Out and Sidetone Options Group Box

The **Matrix Out and Sidetone Options** group box is used to select whether audio from the selected active mic goes out to the Matrix when a talk key is active (NORMAL mode) or audio goes out the Matrix without regard to the talk key state (HOT MIC mode) and at what output level to send it.

Also, from this group box, configure the mode and level at which the user hears their own voice. For more information, see, “Audio Options Menu, Sidetone” on page 200.

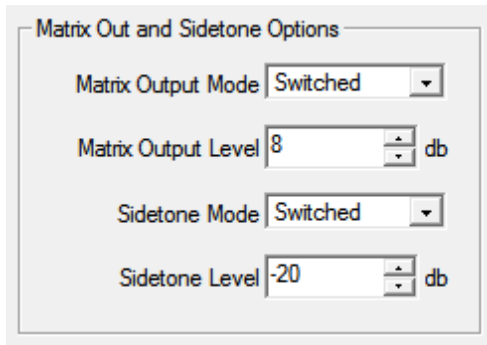

FIGURE 59. Audio Options Page – Matrix Out and Sidetone Options Group Box

To **configure the matrix output mode and level**, do the following:

1. From the Matrix Output Mode, select **Switched** or **Hot Mic**.
2. Using the Matrix Output Level scroll box, adjust the **output level** as desired.

To **configure the sidetone mode and level**, do the following:

1. From the Sidetone Mode, select **Switched**, **Always On**, or **Disabled**.
2. Using the Sidetone Level scroll box, adjust the **Sidetone level** as desired.

Headset Configuration Group Box

The **Headset Configuration** group box is used to define the microphone type – Auto-detect, Dynamic, or Electret. Also from this group box, you configure Auto-Transfer and Auto-Mute.

For more information, see “Type” on page 193, “Auto-Transfer” on page 194, “Auto-Mute” on page 192

Headset	Mic Type	Mic Auto-Mute	Headset Auto-Transfer
Left Headset	Auto Detect	<input checked="" type="checkbox"/>	<input checked="" type="checkbox"/>
Right Headset	Auto Detect	<input checked="" type="checkbox"/>	<input checked="" type="checkbox"/>

Headset Transfer Active

FIGURE 60. Audio Options Page – Headset Configuration Group Box

To **configure a headset**, do the following:

1. From the Mic Type column drop down menu, select **Auto Detect**, **Dynamic**, or **Electret**.
2. Select the **Mic Auto-Mute check box** to automatically mute mic input when a headset mic is not detected.
3. Select the **Headset Auto-Transfer check box** to allow the keypad to automatically enter or leave headset mode when a headset is installed or removed.
4. Select the **Headset Transfer Active check box** to make the headset active.

Ganged Volume Group Box

The **Ganged Volume** group box is used to set what happens when adjusting the volume for a ganged channel pair when the volumes are not identical and one (1) of the volumes reaches the minimum or maximum level.

For more information on the available selections, see “Audio Options Menu, Ganged Vols” on page 192.

Ganged Volumes

Ganged Volume Mode: Disappearing

Ganged Speaker Volume Control

Ganged Headset Volume Control

FIGURE 61. Audio Options Page – Ganged Volumes Group Box

To **configure ganged volumes**, do the following:

1. From the Ganged Volume Mode drop down menu, select **Disappearing** or **Fixed**.
2. Select the **Ganged Speaker Volume Control check box** to enable the speaker volumes to be ganged.
3. Select the **Ganged Headset Volume Control check box** to enable the headset volumes to be ganged.

Tone Generator Group Box

The **Tone Generator** group box is used to define the tone frequency. The tone generator is used to check the audio path from the keypanel to the matrix.

Available selections for this menu are:

500Hz Tone (default)

1kHz Tone

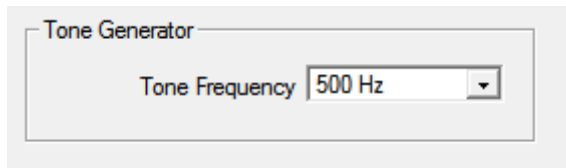

FIGURE 62. Audio Options Page – Tone Generator Group Box

To **configure the tone generator**, do the following:

- > From the Tone Frequency drop down menu, select **500 Hz** or **1000 Hz**.

VM Options Group Box

The **VM Options** group box is used to configure voice messaging playback options and recording options.

For more information, see “Audio Options Menu, VM Options (Audio Package Only)” on page 202.

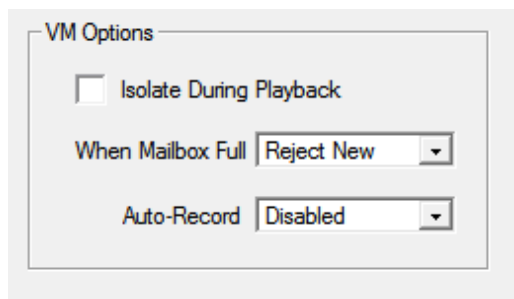

FIGURE 63. Audio Options Page – VM Options Group Box

To **configure voice messaging options**, do the following:

1. Select the **Isolate During Playback check box** to remove all other audio from the speaker or headset when playing back voice messages.
2. From the When Mailbox Full drop down menu, select **Reject New** or **Delete Oldest**.
3. From the Auto-Record drop down menu, select **Disabled** or **Rolling Buffer**.

Audio Levels Page

IMPORTANT: OMNEO 3 through OMNEO 8 only appear when the Audio Package is purchased, otherwise, they do not display.

Keypanel Configuration

Panel Options | Display | Key Options | Audio Options | **Audio Levels** | Advanced | Filters

Input Volumes

Input	Volume
Front Panel Mic	0 dB
Rear Panel Mic	0 dB
Matrix In	-6 dB
OMNEO 2	0 dB
OMNEO 3	0 dB
OMNEO 4	0 dB
OMNEO 5	0 dB
OMNEO 6	0 dB
OMNEO 7	0 dB
Left Headset Mic	0 dB
Right Headset Mic	0 dB
Aux 1	0 dB

Minimum Input Volumes

Input	Volume
Matrix In	-6 dB
OMNEO 2	Mute
OMNEO 3	Mute
OMNEO 4	Mute
OMNEO 5	Mute
OMNEO 6	Mute
OMNEO 7	Mute
Aux 1	Mute

Chime Volumes

Chime	Volume
System Chime #1	-20 dB
System Chime #2	-20 dB
System Chime #3	-20 dB
System Chime #4	-20 dB
System Chime #5	-20 dB
System Chime #6	-20 dB
System Chime #7	-20 dB
System Chime #8	-20 dB
System Chime #9	-20 dB
System Chime #10	-20 dB
System Chime #11	-20 dB
System Chime #12	-20 dB
User Chime #1	-20 dB
User Chime #2	-20 dB
User Chime #3	-20 dB
User Chime #4	-20 dB

Chime Preview

Output Volumes

Output	Volume
Front Speaker	3 dB
Rear Speaker	0 dB
Left Headset	0 dB
Right Headset	0 dB

Minimum Output Volumes

Output	Volume
Front Speaker	Mute
Rear Speaker	Mute
Left Headset	Mute
Right Headset	Mute

Output Dim Amounts

Output	Dim Amount
Front Speaker	-8 dB
Rear Speaker	-8 dB
Left Headset	0 dB
Right Headset	0 dB

Maximum Output Volumes

Output	Volume
Front Speaker	10 dB
Rear Speaker	10 dB
Left Headset	10 dB
Right Headset	10 dB

Load | Save All | Save Changes | Apply | Cancel

FIGURE 64. Keypanel Configuration – Audio Levels

Input Volumes Group Box

The **Input Volumes** group box is used to adjust the current volume, in dB, for all input sources.

IMPORTANT: OMNEO 3 through OMNEO 8 only appear when the Audio Package is purchased, otherwise, they do not display.

The range for this field is *Mute and -48dB to 10dB*.

The default setting is *0dB*.

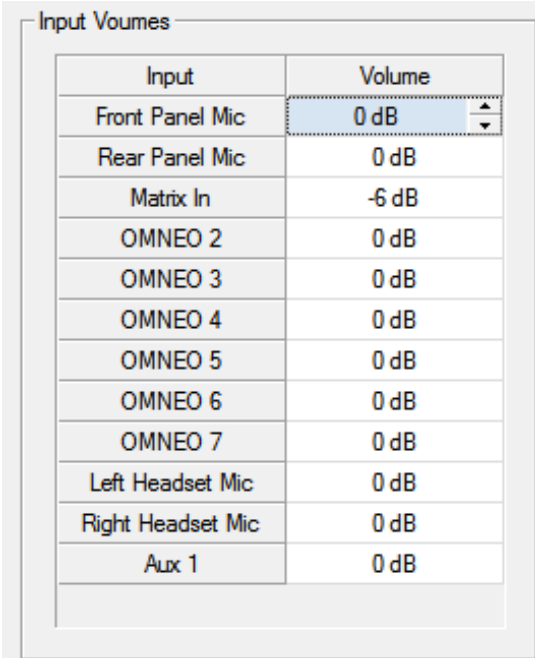

The screenshot shows a window titled "Input Volumes" containing a table with two columns: "Input" and "Volume". The "Front Panel Mic" row is highlighted, and its volume is set to "0 dB" with a spin box control. Other inputs include Rear Panel Mic, Matrix In, OMNEO 2-7, Left Headset Mic, Right Headset Mic, and Aux 1, all with volume values of 0 dB or -6 dB.

Input	Volume
Front Panel Mic	0 dB
Rear Panel Mic	0 dB
Matrix In	-6 dB
OMNEO 2	0 dB
OMNEO 3	0 dB
OMNEO 4	0 dB
OMNEO 5	0 dB
OMNEO 6	0 dB
OMNEO 7	0 dB
Left Headset Mic	0 dB
Right Headset Mic	0 dB
Aux 1	0 dB

FIGURE 65. Audio Levels Page – Input Volumes Group Box

To **configure input volumes**, do the following:

- > Using the Volume column spin box, adjust the **volume** for the input desired.

Output Volumes Group Box

The **Output Volumes** group box is used to set the volume level, in dB, for outputs at the keypad. This is the volume level available when using the Main Volume control knob, located on the front of the keypad.

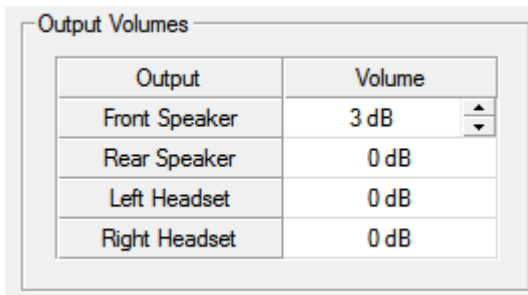

Output	Volume
Front Speaker	3 dB
Rear Speaker	0 dB
Left Headset	0 dB
Right Headset	0 dB

FIGURE 66. Audio Levels Page – Output Volumes Group Box

To **configure output volumes**, do the following:

- > Using the Volume column spin box, adjust the **volume** for the output desired.

Output Dim Amounts Group Box

The **Output Dim Amounts** group box is used to set how much the output is dimmed when a talk key is pressed..

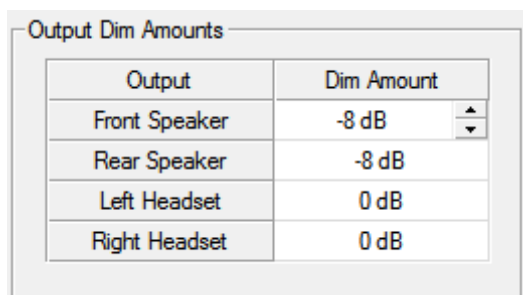

Output	Dim Amount
Front Speaker	-8 dB
Rear Speaker	-8 dB
Left Headset	0 dB
Right Headset	0 dB

FIGURE 67. Audio Levels Page – Output Dim Amounts Group Box

To **configure output dim amounts**, do the following:

- > Using the Volume column spin box, adjust the **output dim** for the output desired.

Minimum Input Volumes Group Box

The **Minimum Input Volume** group box is used to set the minimum volume level, in dB, for different sources on the keypanel. This is the minimum volume level available when using the Aux Volume control knob, located on the front of the keypanel.

IMPORTANT: OMNEO 3 through OMNEO 8 only appear when the Audio Package is purchased, otherwise, they do not display.

The range for this field is *Mute and -48dB to 10dB*.

By default, this field for Matrix In is set to *-6dB*; all other inputs are set to *Mute*.

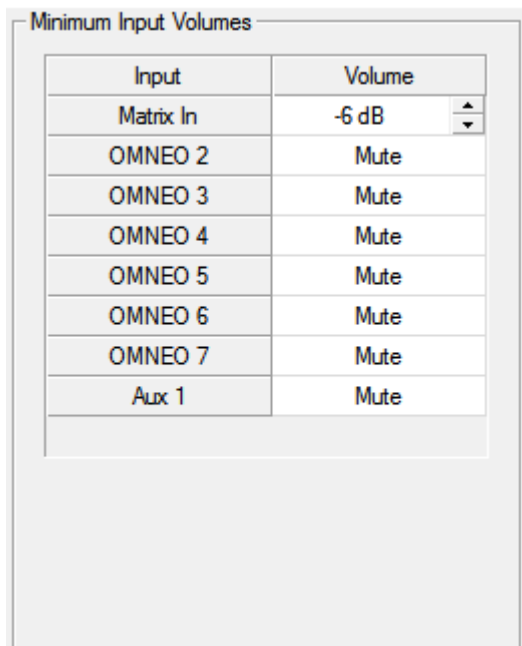

Input	Volume
Matrix In	-6 dB
OMNEO 2	Mute
OMNEO 3	Mute
OMNEO 4	Mute
OMNEO 5	Mute
OMNEO 6	Mute
OMNEO 7	Mute
Aux 1	Mute

FIGURE 68. Audio Levels Page – Minimum Input Volumes

To **configure input volumes**, do the following:

- > Using the Volume column spin box, adjust the **volume** for the input desired.

Minimum Output Volumes Group Box

The **Minimum Output Volume** group box is used to set the minimum volume level, in dB, for different outputs on the keypanel. This is the minimum volume level available when using the Main Volume control knob, located on the front of the keypanel.

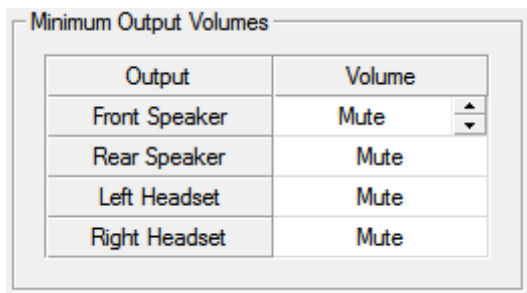

Output	Volume
Front Speaker	Mute
Rear Speaker	Mute
Left Headset	Mute
Right Headset	Mute

FIGURE 69. Audio Levels Page – Minimum Output Volumes Group Box

To **configure the minimum output volumes**, do the following:

- > Using the Volume column spin box, adjust the **minimum volume** for the output desired.

Maximum Output Volumes Group Box

The **Maximum Output Volumes** group box is used to set the maximum level, in dB, of the volume the user can configure for a headset or a speaker. This feature prevents incoming audio from being too loud.

The range for this field is *Mute and -48dB to 10dB*.

The default setting is *10dB*.

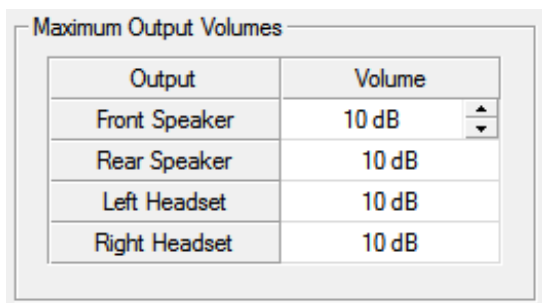

Output	Volume
Front Speaker	10 dB
Rear Speaker	10 dB
Left Headset	10 dB
Right Headset	10 dB

FIGURE 70. Audio Levels Page – Maximum Output Volumes Group Box

To **configure maximum output volumes**, do the following:

- > Using the Volume column spin box, adjust the **maximum volume** for the output desired.

Chime Volumes Group Box

The **Chime Volumes** group box is used to set the volume for each of the built-in chimes, as well as to enable or disable preview of chimes during chime selection in this menu and others that reference chimes.

For a description of the range of volumes available, see “Audio Options Menu, Chime” on page 191.

Chime	Volume
System Chime #1	-20 dB
System Chime #2	-20 dB
System Chime #3	-20 dB
System Chime #4	-20 dB
System Chime #5	-20 dB
System Chime #6	-20 dB
System Chime #7	-20 dB
System Chime #8	-20 dB
System Chime #9	-20 dB
System Chime #10	-20 dB
System Chime #11	-20 dB
System Chime #12	-20 dB
User Chime #1	-20 dB
User Chime #2	-20 dB
User Chime #3	-20 dB
User Chime #4	-20 dB

Chime Preview

FIGURE 71. Audio Levels Page – Chime Volumes Group Box

IMPORTANT: User Chimes are only present when the Audio Package is installed.

To **configure chime volumes**, do the following:

1. From the Volume column spin box, adjust the **volume for the System or User Chime** desired.
2. Select the **Chime Preview check box** to hear a preview of the chime on the keypad each time a new chime is selected or while the volume is being adjusted.

Advanced Page

IMPORTANT: OMNEO 3 through OMNEO 8 only appear when the Audio Package is purchased; otherwise, they do not display.

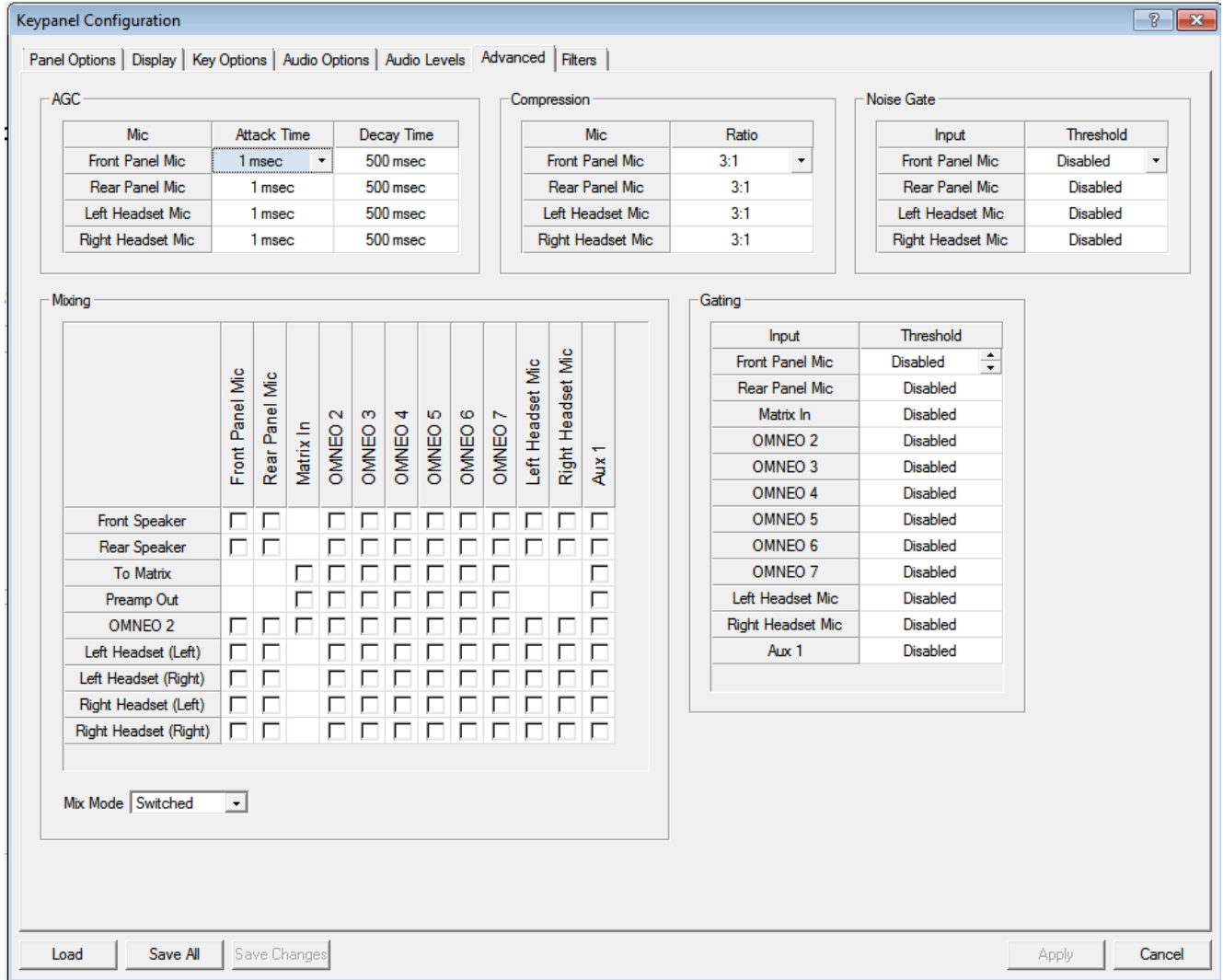
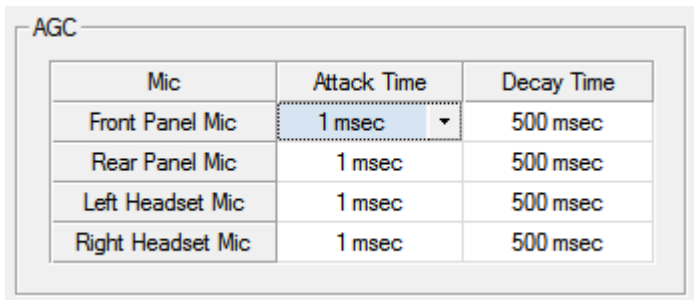

FIGURE 72. Keypanel Configuration – Advanced

AGC Group Box

The **AGC** (Automatic Gain Control) group box is used to set the speed at which a microphone becomes active and the speed at which a sustainable level is achieved through the use of the Attack menu and the Decay menu. You can set these levels for the front, rear, and headset microphones used with the keypanel. For information on available selections, see “AGC” on page 179.



Mic	Attack Time	Decay Time
Front Panel Mic	1 msec ▾	500 msec
Rear Panel Mic	1 msec	500 msec
Left Headset Mic	1 msec	500 msec
Right Headset Mic	1 msec	500 msec

FIGURE 73. Advanced Page – AGC Group Box

To **configure AGC**, do the following:

1. From the Attack Time column drop down menu, select the **speed to configure for Attack** (microphone is active).
2. From the Decay Time column drop down menu, select the **speed to configure for Decay** (microphone is at sustainable level).

Mixing Group Box

The **Mixing** group box allows you to route selected input audio signals to different destinations. For a complete list of destinations and more information, see “Mixing” on page 188.

IMPORTANT: OMNEO 3 through OMNEO 8 only appear when the Audio Package is purchased, otherwise, they do not display.

	Front Panel Mic	Rear Panel Mic	Matrix In	OMNEO 2	OMNEO 3	OMNEO 4	OMNEO 5	OMNEO 6	OMNEO 7	Left Headset Mic	Right Headset Mic	Aux 1
Front Speaker	<input type="checkbox"/>	<input type="checkbox"/>		<input type="checkbox"/>	<input type="checkbox"/>	<input type="checkbox"/>	<input type="checkbox"/>	<input type="checkbox"/>	<input type="checkbox"/>	<input type="checkbox"/>	<input type="checkbox"/>	<input type="checkbox"/>
Rear Speaker	<input type="checkbox"/>	<input type="checkbox"/>		<input type="checkbox"/>	<input type="checkbox"/>	<input type="checkbox"/>	<input type="checkbox"/>	<input type="checkbox"/>	<input type="checkbox"/>	<input type="checkbox"/>	<input type="checkbox"/>	<input type="checkbox"/>
To Matrix			<input type="checkbox"/>	<input type="checkbox"/>	<input type="checkbox"/>	<input type="checkbox"/>	<input type="checkbox"/>	<input type="checkbox"/>	<input type="checkbox"/>			<input type="checkbox"/>
Preamp Out			<input type="checkbox"/>	<input type="checkbox"/>	<input type="checkbox"/>	<input type="checkbox"/>	<input type="checkbox"/>	<input type="checkbox"/>	<input type="checkbox"/>			<input type="checkbox"/>
OMNEO 2	<input type="checkbox"/>	<input type="checkbox"/>	<input type="checkbox"/>	<input type="checkbox"/>	<input type="checkbox"/>	<input type="checkbox"/>	<input type="checkbox"/>	<input type="checkbox"/>	<input type="checkbox"/>	<input type="checkbox"/>	<input type="checkbox"/>	<input type="checkbox"/>
Left Headset (Left)	<input type="checkbox"/>	<input type="checkbox"/>		<input type="checkbox"/>	<input type="checkbox"/>	<input type="checkbox"/>	<input type="checkbox"/>	<input type="checkbox"/>	<input type="checkbox"/>	<input type="checkbox"/>	<input type="checkbox"/>	<input type="checkbox"/>
Left Headset (Right)	<input type="checkbox"/>	<input type="checkbox"/>		<input type="checkbox"/>	<input type="checkbox"/>	<input type="checkbox"/>	<input type="checkbox"/>	<input type="checkbox"/>	<input type="checkbox"/>	<input type="checkbox"/>	<input type="checkbox"/>	<input type="checkbox"/>
Right Headset (Left)	<input type="checkbox"/>	<input type="checkbox"/>		<input type="checkbox"/>	<input type="checkbox"/>	<input type="checkbox"/>	<input type="checkbox"/>	<input type="checkbox"/>	<input type="checkbox"/>	<input type="checkbox"/>	<input type="checkbox"/>	<input type="checkbox"/>
Right Headset (Right)	<input type="checkbox"/>	<input type="checkbox"/>		<input type="checkbox"/>	<input type="checkbox"/>	<input type="checkbox"/>	<input type="checkbox"/>	<input type="checkbox"/>	<input type="checkbox"/>	<input type="checkbox"/>	<input type="checkbox"/>	<input type="checkbox"/>

Mix Mode: Switched (dropdown menu showing Switched and Always On)

FIGURE 74. Advanced Page – Mixing Group Box

To **mix inputs and outputs**, do the following:

1. Using both axis lists, select the **check boxes that correlate to the inputs and outputs you want to mix.**
2. From the Mix Mode drop down menu, select **Switched** or **Always On.**

For more information on Mix Mode, see “Mix Mode” on page 190.

IMPORTANT: Not every input can be mixed to every output. Check boxes are not present for mixes that cannot be set here. Some mixes are made using the Headset/Speaker and Headset Mic/Panel Mic menus when setting the modes to Always On/Enabled, Disabled, or Switched.

Compression Group Box

The **Compression** group box is used to change the audio's gain, meaning audio above the noise gate threshold is changed according to the compression ratio selected. The compression is used to change the dynamic range of the mic input. This means loud sounds are softened; while soft sounds are amplified.

IMPORTANT: Compression ratios 4:1, 5:1, and 6:1 are only available with the purchase of the Audio Package. For more information, see "Audio and Control Packages" on page 279.

For more information on compression values available, see "Compression" on page 180.

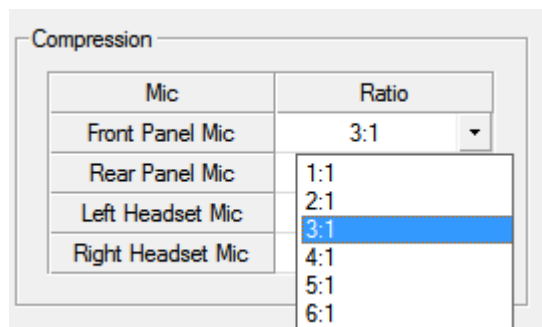

FIGURE 75. Advanced Page – Compression Group Box

To **configure compression on a microphone**, do the following:

- > From the Ratio column drop down menu, select the **compression ratio** desired.

Gating Group Box

The **Gating** group box is used to minimize or eliminate background noise problems by shutting off an audio source when the audio level drops below a certain threshold.

IMPORTANT: OMNEO 3 through OMNEO 8 only appear when the Audio Package is purchased, otherwise, they do not display.

The range for the gating threshold is $-17dB$ to $+18dB$, and *Disabled*.
By default, the gating threshold is set to *Disabled*.

Input	Threshold
Front Panel Mic	Disabled
Rear Panel Mic	Disabled
Matrix In	Disabled
OMNEO 2	Disabled
OMNEO 3	Disabled
OMNEO 4	Disabled
OMNEO 5	Disabled
OMNEO 6	Disabled
OMNEO 7	Disabled
Left Headset Mic	Disabled
Right Headset Mic	Disabled

FIGURE 76. Advanced Page – Gating Group Box

To **configure gating on an input**, do the following:

- > Using the Threshold column enable and set the **threshold you desire for the input of your choice**.

Noise Gate Group Box

The **Noise Gate** menu is used to enable, disable or adjust (if licensed) the audio level at which the mic turns on.

If not licensed, noise gate can be enabled or disabled. When enabled, microphone noise gate is set to -72dBu; when the noise gate is disabled, the microphone is always on.

If licensed for the Audio Package, you have the ability to adjust the threshold level of the noise gate, giving you more flexibility configuring the noise gate.

Available options are: *Disabled, -87 dBu, -84 dBu, -81 dBu, -78 dBu, -75 dBu, -72 dBu, -69 dBu, -66 dBu, -63 dBu, -60 dBu, -57 dBu, -54 dBu, -51 dBu, -48 dBu, -48 dBu, or -42 dBu.*

For more information, see “Noise Gate” on page 190.

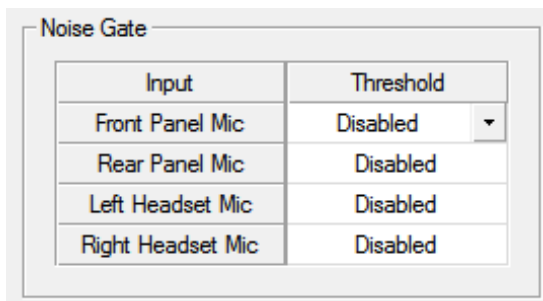

FIGURE 77. Advanced Page – Noise Gate Group Box

To **enable and adjust the noise gate**, do the following:

- > Using the scroll box in the Threshold column, enable and set the **threshold for the input desired**.

Filters Page

The **Filters** page is used to add input and output bandpass filters, frequency response (equalization) filters or notch filters to one (1) or more audio sources.

IMPORTANT: OMNEO 3 through OMNEO 8 only appear when the Audio Package is purchased, otherwise, they do not display.

Keypanel Configuration

Panel Options | Display | Key Options | Audio Options | Audio Levels | Advanced | Filters

Input Bandpass Filters

Input	Enabled	Low Freq	High Freq
OMNEO 2	<input type="checkbox"/>	0 Hz	22 kHz
OMNEO 3	<input type="checkbox"/>	0 Hz	22 kHz
OMNEO 4	<input type="checkbox"/>	0 Hz	22 kHz
OMNEO 5	<input type="checkbox"/>	0 Hz	22 kHz
OMNEO 6	<input type="checkbox"/>	0 Hz	22 kHz
OMNEO 7	<input type="checkbox"/>	0 Hz	22 kHz
OMNEO 8	<input type="checkbox"/>	0 Hz	22 kHz

Input Equalization Filters

Input	Enabled	Preset	Low Freq	High Freq	Gains
Front Panel Mic	<input checked="" type="checkbox"/>		50 Hz	12.6 kHz	<edit>
Rear Panel Mic	<input checked="" type="checkbox"/>		50 Hz	12.6 kHz	<edit>
Matrix In	<input type="checkbox"/>		15.6 Hz	20 kHz	<edit>
Left Headset Mic	<input checked="" type="checkbox"/>		50 Hz	12.6 kHz	<edit>
Right Headset Mic	<input checked="" type="checkbox"/>		50 Hz	12.6 kHz	<edit>

Output Bandpass Filters

Output	Enabled	Low Freq	High Freq
To Matrix	<input type="checkbox"/>	0 Hz	22 kHz
Preamp Out	<input type="checkbox"/>	0 Hz	22 kHz
OMNEO 2	<input type="checkbox"/>	0 Hz	22 kHz
VM Playback	<input type="checkbox"/>	0 Hz	22 kHz
Left Headset (Left)	<input type="checkbox"/>	0 Hz	22 kHz
Left Headset (Right)	<input type="checkbox"/>	0 Hz	22 kHz
Right Headset (Left)	<input type="checkbox"/>	0 Hz	22 kHz
Right Headset (Right)	<input type="checkbox"/>	0 Hz	22 kHz

Output Equalization Filters

Output	Enabled	Preset	Low Freq	High Freq	Gains
Front Speaker	<input type="checkbox"/>		15.6 Hz	20 kHz	<edit>
Rear Speaker	<input type="checkbox"/>		15.6 Hz	20 kHz	<edit>

Notch Filter Mode: Disabled

Load Save All Save Changes Apply Cancel

FIGURE 78. Keypanel Configuration – Filters Page

Input Bandpass Filters Group Box

The **Input Bandpass Filters** group box is used to enable bandpass filters which set a low and high frequency range where frequencies within the two (2) frequency points are passed and anything outside of the range is rejected.

IMPORTANT: OMNEO 3 through OMNEO 8 only appear when the Audio Package is purchased, otherwise, they do not display.

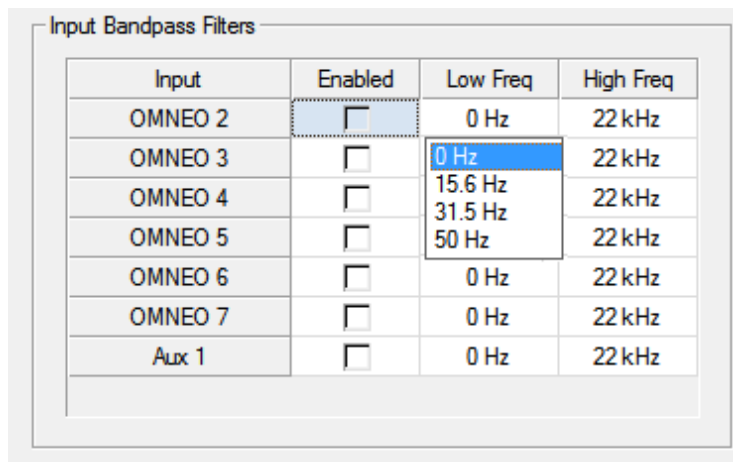

Input	Enabled	Low Freq	High Freq
OMNEO 2	<input type="checkbox"/>	0 Hz	22 kHz
OMNEO 3	<input type="checkbox"/>	0 Hz	22 kHz
OMNEO 4	<input type="checkbox"/>	15.6 Hz	22 kHz
OMNEO 5	<input type="checkbox"/>	31.5 Hz	22 kHz
OMNEO 6	<input type="checkbox"/>	50 Hz	22 kHz
OMNEO 7	<input type="checkbox"/>	0 Hz	22 kHz
Aux 1	<input type="checkbox"/>	0 Hz	22 kHz

FIGURE 79. Filters Page – Input Bandpass Filters Group Box

To **configure input bandpass filters**, do the following:

1. Select the **Enabled column check box** for the input you want to set a bandpass filter.
2. From the Low Freq column drop down menu, select the **low frequency** you desire.
3. From the High Freq column drop down menu, select the **high frequency** you desire.

Output Bandpass Filters Group Box

The **Output Bandpass Filters** group box is used to enable bandpass filters which set a low and high frequency range where frequencies within the two (2) frequency points are passed and anything outside of the range is rejected.

Output	Enabled	Low Freq	High Freq
To Matrix	<input checked="" type="checkbox"/>	0 Hz	22 kHz
Preamp Out	<input type="checkbox"/>	0 Hz	22 kHz
OMNEO 2	<input type="checkbox"/>	0 Hz	16 kHz
VM Playback	<input type="checkbox"/>	0 Hz	8 kHz
Left Headset (Left)	<input type="checkbox"/>	0 Hz	4 kHz
Left Headset (Right)	<input type="checkbox"/>	0 Hz	22 kHz
Right Headset (Left)	<input type="checkbox"/>	0 Hz	22 kHz
Right Headset (Right)	<input type="checkbox"/>	0 Hz	22 kHz

FIGURE 80. Filters Page – Output Bandpass Filters Group Box

To **configure output bandpass filters**, do the following:

1. Select the **Enabled column check box** for the input you want to set a bandpass filter.
2. From the Low Freq column drop down menu, select the **low frequency** you desire.
3. From the High Freq column drop down menu, select the **high frequency** you desire.

Input Equalization Filters Group Box

Equalization allows the user to select predefined settings that modify the frequency envelope of an audio channel. This is a 5-band equalizer. Each preset provides a different EQ to be applied to the audio.

For more information on available options, see “Equalization” on page 182.

IMPORTANT: Included in the purchased audio package, is an adjustable 5-band equalizer giving you the ability adjust the low and high frequency cutoff filters and the gain for each band. This feature is in addition to the preset frequencies that comes standard on the keypad. If the audio package is not purchased the high, low frequency and band gains all display as read only.

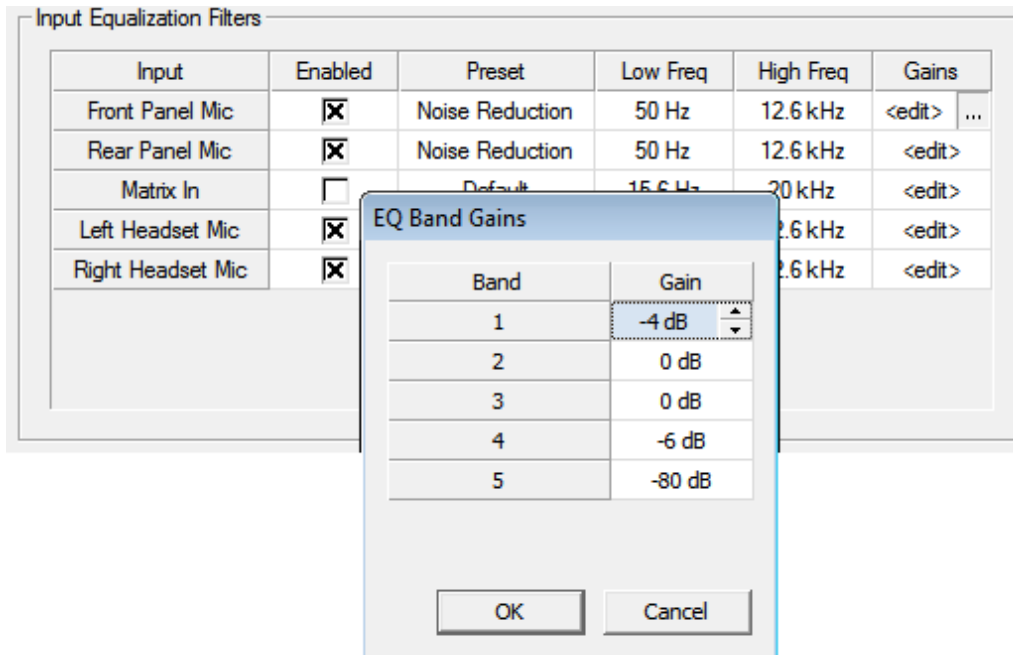



FIGURE 81. Filters Page – Input Equalization Filters Group Box

To **configure the input equalization filters**, do the following:

1. Select the **Enabled column check box** next to the input you want to filter.
2. From the Preset column drop down menu, select the **preset you want to use**, if desired.

IMPORTANT: You can only change the frequencies and gains if licensed.

3. From the Low Freq column drop down menu, select the **low frequency** you desire.
4. From the High Freq column drop down menu, select the **high frequency** you desire.
5. Click the Gain column **browse button** . *The Band Gain window appears.*
6. Using the Gain scroll box, adjust the **gain for the appropriate band**.
7. Click **OK**.

Output Equalization Filters Group Box

Equalization allows the user to select predefined settings that modify the frequency envelope of an audio channel. This is a 5-band equalizer. Each preset provides a different EQ to be applied to the audio.

For more information on available options, see “Equalization” on page 182.

IMPORTANT: Included in the purchased audio package, is an adjustable 5-band equalizer giving you the ability adjust the low and high frequency cutoff filters and the gain for each band. This feature is in addition to the preset frequencies that comes standard on the keypanel.

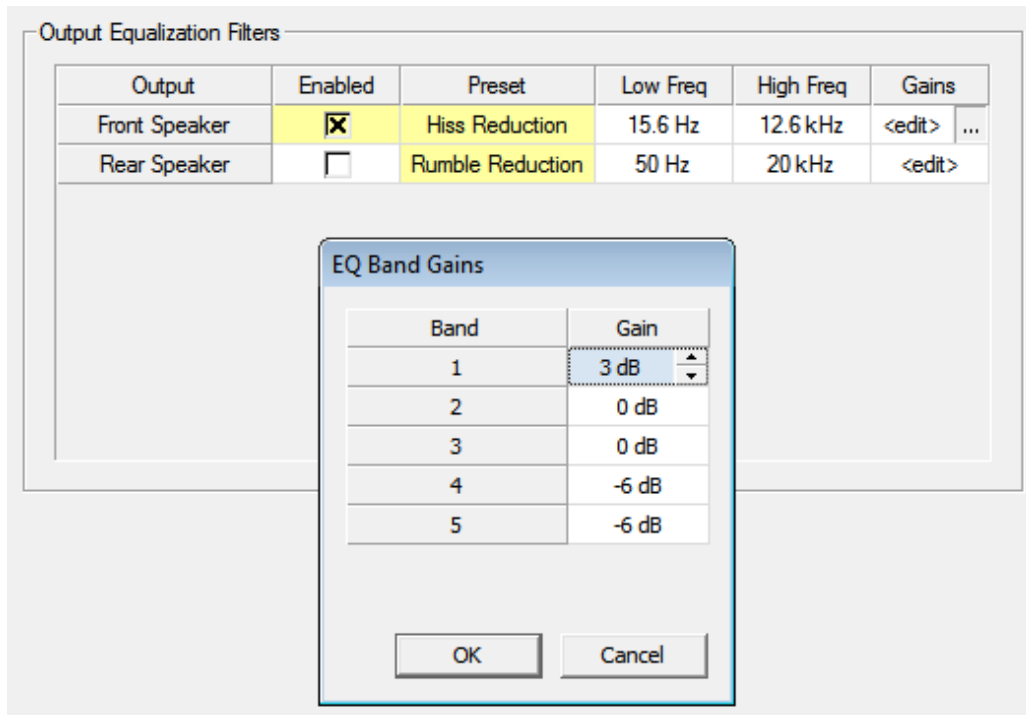



FIGURE 82. Filters Page – Output Equalization Filters Group Box

To **configure the output equalization filters**, do the following:

1. Select the **Enabled column check box** next to the output you want to filter.
2. From the Preset column drop down menu, select the **preset you want to use**, if desired.

IMPORTANT: You can only change the frequencies and gains if licensed.

3. From the Low Freq column drop down menu, select the **low frequency** you desire.
4. From the High Freq column drop down menu, select the **high frequency** you desire.
5. Click the Gain column **browse button** .
The Band Gain window appears.
6. Using the Gain scroll box, adjust the **gain for the appropriate band**.
7. Click **OK**.

Notch Filter Mode

The **Notch** filter allows you to add a notch to the Matrix In source - either AIO or OMNEO channel 1. This can be useful when the keypad data port signal is being heard in the audio line due to cable routing problems.

For descriptions of the available selections, see “Notch” on page 185.

By default, the notch filter is set to *Disabled*.

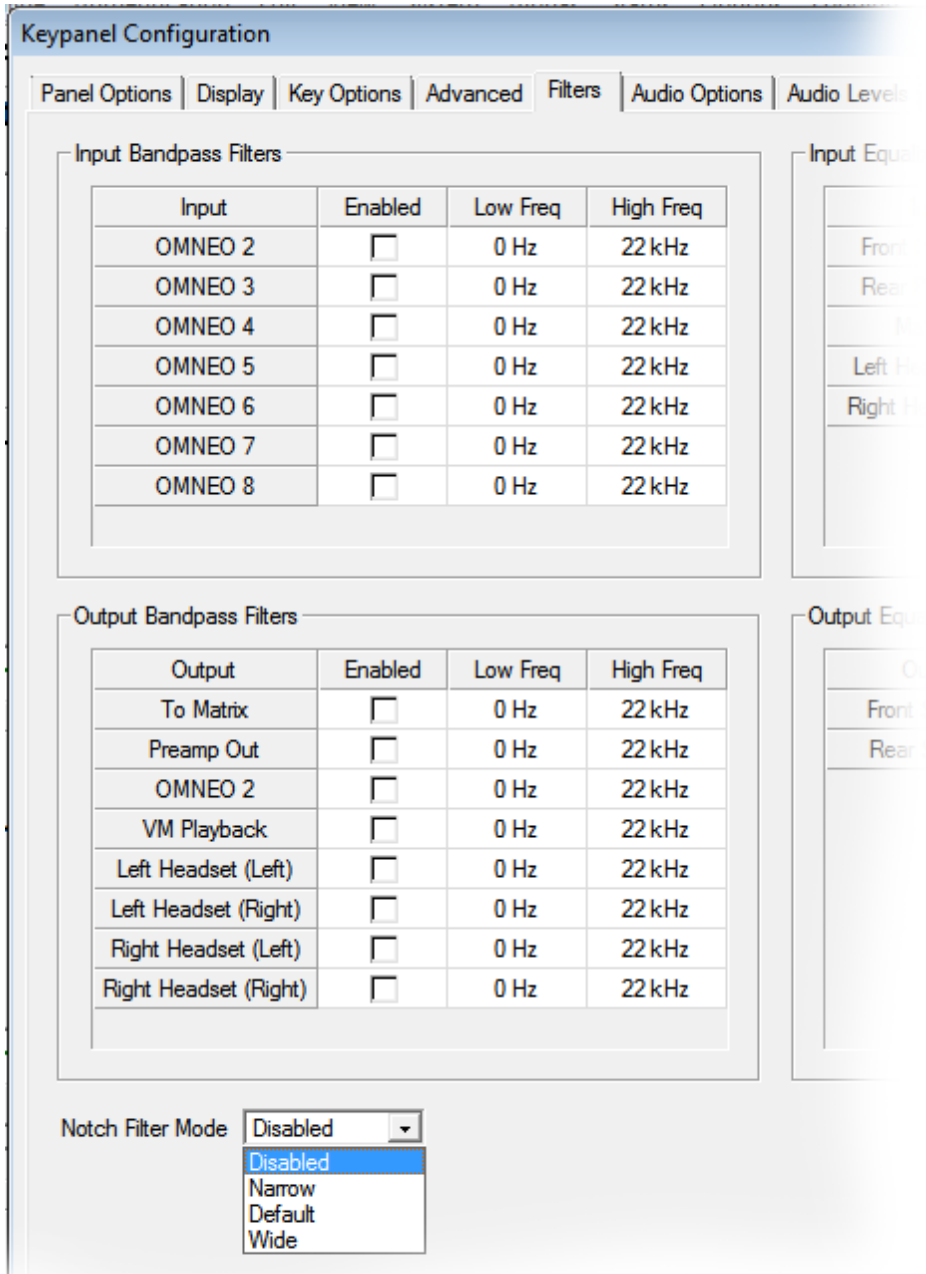

FIGURE 83. Filters Page – Notch Filter Mode Selection

To **set the notch filter**, do the following:

- > From the Notch Filter Mode drop down menu, select **Disabled**, **Narrow**, **Default**, or **Wide**.

Firmware Download

NOTE: The instructions provided below are shown using the KP-5032, but are applicable for all family keypanels.

Download Firmware to the DKP-4016/4016W From AZedit

To **download firmware to the keypanel**, do the following:

1. Open **AZedit**.
2. From the Status menu, select **Port**.
The Port Status window appears.
3. Find the **port number** where the DKP-4016/4016W is assigned.

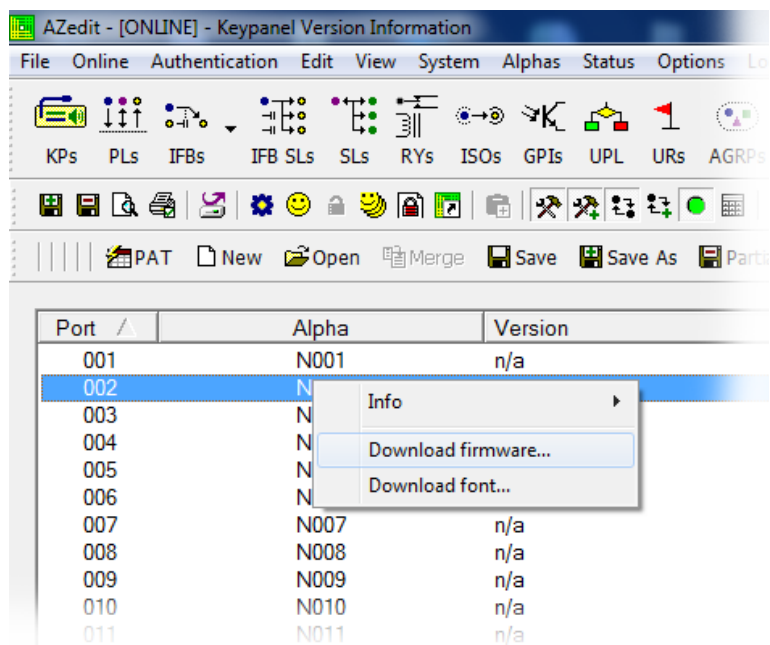

4. Highlight the **Port** (keypanel) to be updated.
You may select more than one (1) at a time by holding CTRL key down while you select.
5. Right-click the **highlighted selections**.
A popup menu appears.
6. Select **Download firmware....**
The Firmware Download window appears.

7. Using the browse button, browse to the **file to be downloaded**.
8. Click **Open**.

The Download Device Firmware window appears.

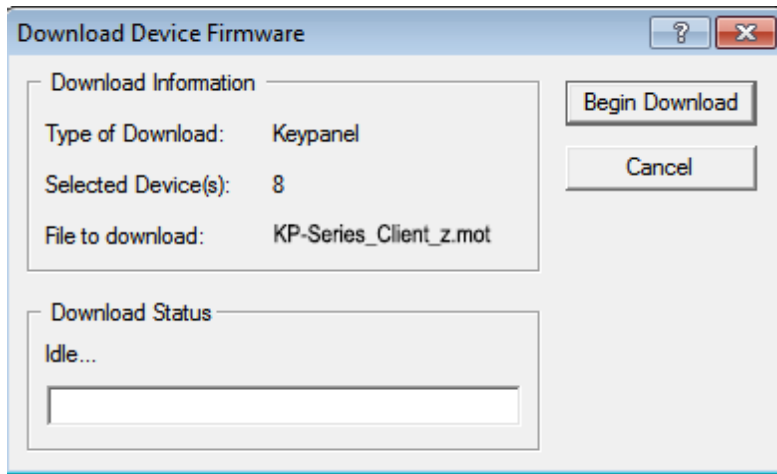

9. Click **Begin Download**.

The download begins.

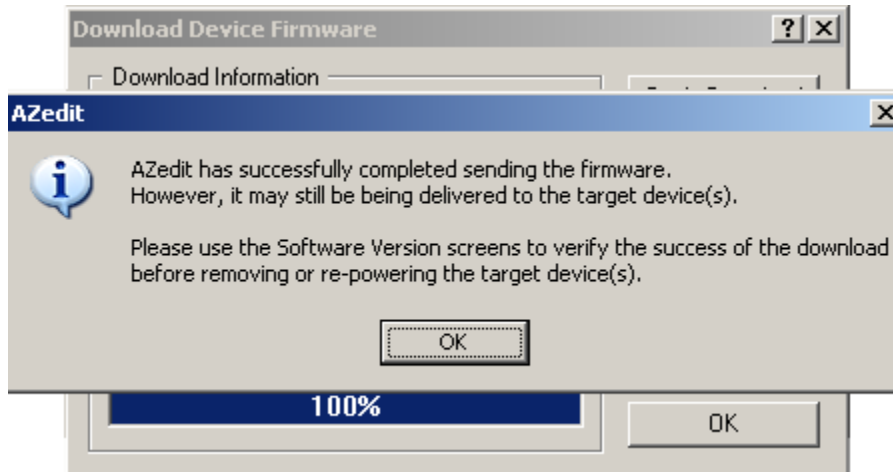

10. Click **OK**.

The DKP-4016/4016W firmware download finishes.

NOTE:

- This can take up to 2 minutes to complete if connected via OMNEO and up to 15 minutes to complete if connected via AIO. Use the Keypanel Version Information window to follow the progress of the download. Also, the keypanel displays Firmware Download on the panel display until the download is complete.
- The DKP-4016/4016W resets itself once the firmware download is complete and the flash is reprogrammed.
- While the firmware is downloading, chunk progress is displayed by incremental blocks. Also, the keypanel displays an icon warning not to turn off the panel while the flash is being reprogrammed.

11. In the Keypanel Version Information window, verify the **version upgrade**.

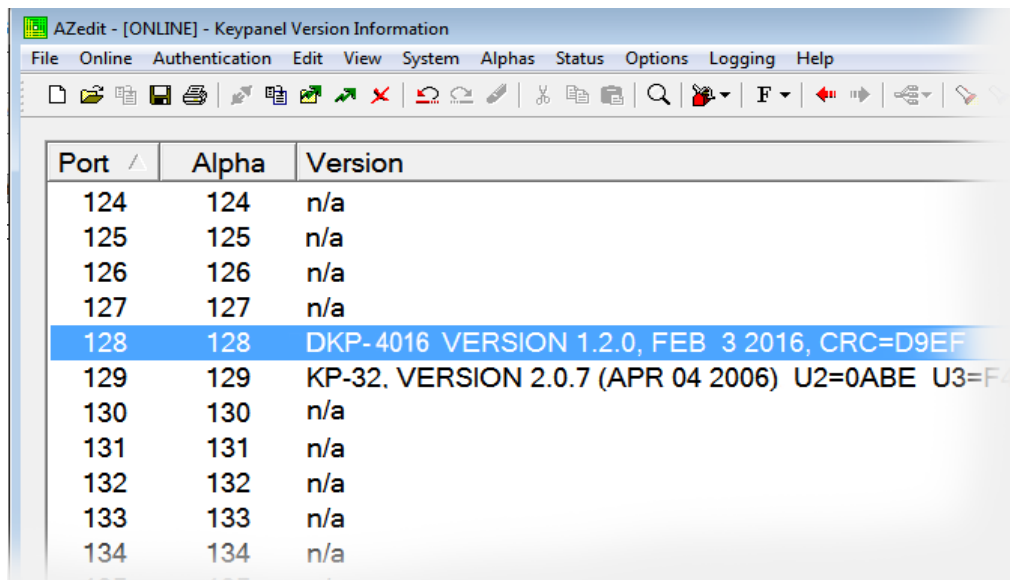

Port	Alpha	Version
124	124	n/a
125	125	n/a
126	126	n/a
127	127	n/a
128	128	DKP-4016 VERSION 1.2.0, FEB 3 2016, CRC=D9EF
129	129	KP-32, VERSION 2.0.7 (APR 04 2006) U2=0ABE U3=F
130	130	n/a
131	131	n/a
132	132	n/a
133	133	n/a
134	134	n/a

Download Firmware to the Keypanel Using the Firmware Upload Tool

Required Firmware version:

FWUT *V4.2.0 or later*

To **download firmware to the keypanel**, do the following:

1. Open the **Firmware Upload Tool**.
2. From the File menu, select **Options**.
The Firmware Upload Tool Options window appears.

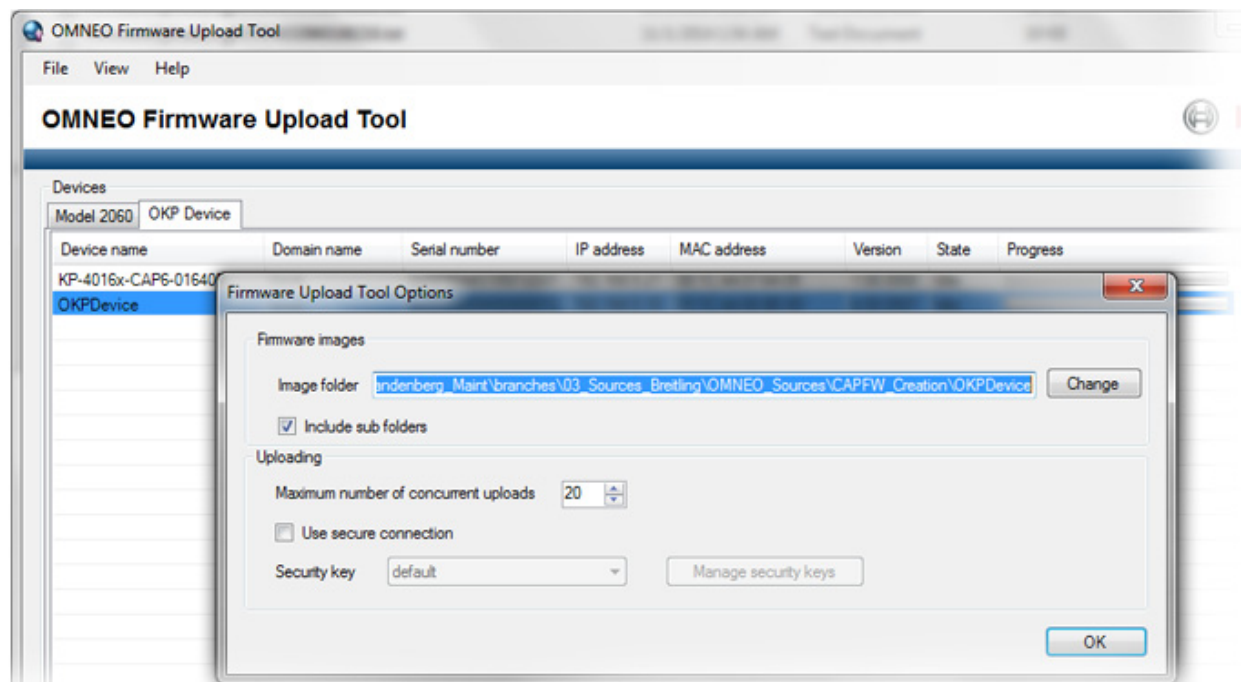

3. Click the **Change button**.
The folder network window appears.
4. Navigate to the **folder** where the firmware resides.
5. Click **OK**.
6. Click **OK**, again.
The Firmware Upload Tool Options window closes.
7. From the OKP Device page, select the **device** you want to update.

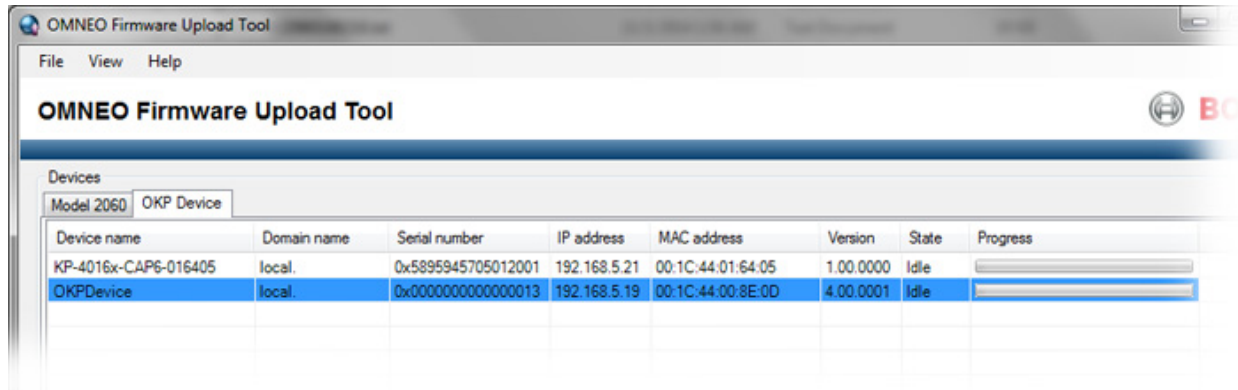

8. Click the **Upload button**.
The Select Firmware for Upload window appears.
9. From the list of firmware, select the **firmware** you want to download.

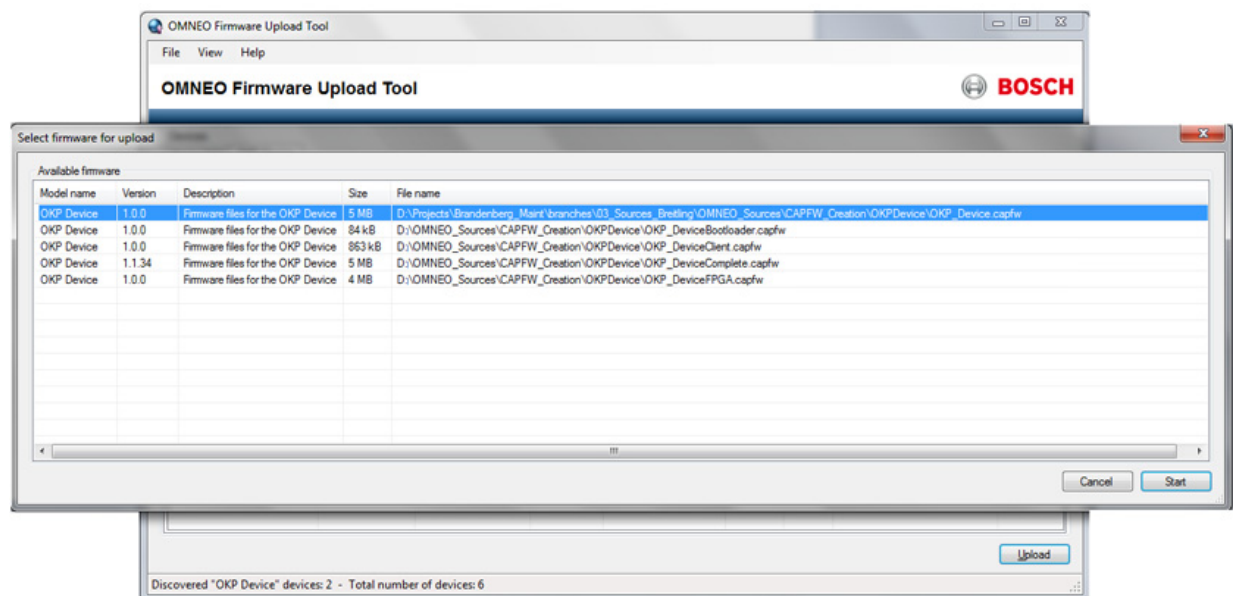

10. Click the **Start button**.
11. Once the firmware has been updated, the keypanel **reboots** automatically.

Enable Downloading New Bootloader from the Keypanel

By default, the keypanel does not allow downloading different bootloader version – this can be enable in the keypanel menu.

To **enable the bootloader firmware downloads on the keypanel**, do the following:

1. While pressing the Main Vol and Aux Vol encoders on the front of the keypanel at the same time, press the **MENU button**.
The main menu appears in the panel display.
2. Using the left and right arrow buttons, select **Service**.
3. Press the **SEL button**.
The Service menu options appear in the panel display.
4. Using the left and right arrow buttons, select **Boot Code**.
5. Press the **SEL button**.
Allow Download and Version X.X.X (where X represents version numbers) appears in the panel display.
6. Using the left and right arrow buttons, select **Allow Download**.
7. Press the **SEL button**.
The keypanel now allows download of new bootloader firmware.

NOTE: If the keypanel is powered off or loses power, the state of the Allow Download option resets to not enabled. You must reconfigure the option for it to allow new bootloader firmware to be downloaded.

Download Firmware Using the Bootloader

The **Bootloader** is used to upload a new bootloader image or to upgrade the keypanel firmware if it is corrupt or fails and makes downloading of new firmware impossible.

If the keypanel firmware is corrupt, the panel may boot automatically into the bootloader. However, if the keypanel firmware appears valid, but fails to run properly, you may need to force the keypanel into the bootloader in order to download the new firmware.

NOTE: The instructions provided below are shown using the KP-5032 family keypanels.

Run the Bootloader

To **run the bootloader**, do the following:

1. Power **off** the keypanel.
2. Verify the **DKP-4016/4016W is powered off**, but still connected to the FRAME.

- At the same time, press and hold **keypanel key 15 in the listen position (up)** and **keypanel key 16 in the talk position (down)**, while you connect the **power cord** to the keypanel.
DKP-4016 - Boot Loader Waiting for download... appears in the panel display.



- In AZedit, from the Status menu, select **Software Versions**.
The Software Versions popup menu appears.

- From the Software Versions popup menu, select **Keypanels**.
The Keypanel Version Information window appears.

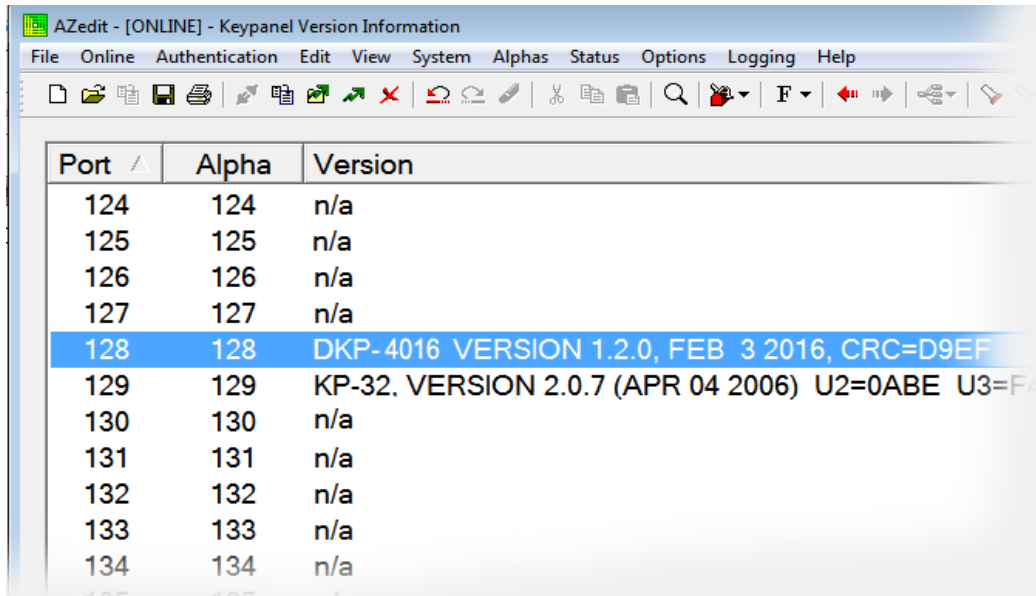

Port	Alpha	Version
124	124	n/a
125	125	n/a
126	126	n/a
127	127	n/a
128	128	DKP-4016 VERSION 1.2.0, FEB 3 2016, CRC=D9EF
129	129	KP-32, VERSION 2.0.7 (APR 04 2006) U2=0ABE U3=F4
130	130	n/a
131	131	n/a
132	132	n/a
133	133	n/a
134	134	n/a

- From the Keypanel Version Information window, find and select the **specified DKP-4016/4016W**.

NOTE: Notice the Version column is showing DKP-4016/4016W Bootloader Version 1.2.0 is shown.

- Right-click on the **DKP-4016/4016W**.
A popup menu appears.
- From the popup menu, select **Download Firmware...**
The Firmware Download navigation window appears.
- Navigate to and select your **firmware file** (i.e., KP-Series_client_z.mot).
- Click **Open**.
The Download Device Firmware window appears.

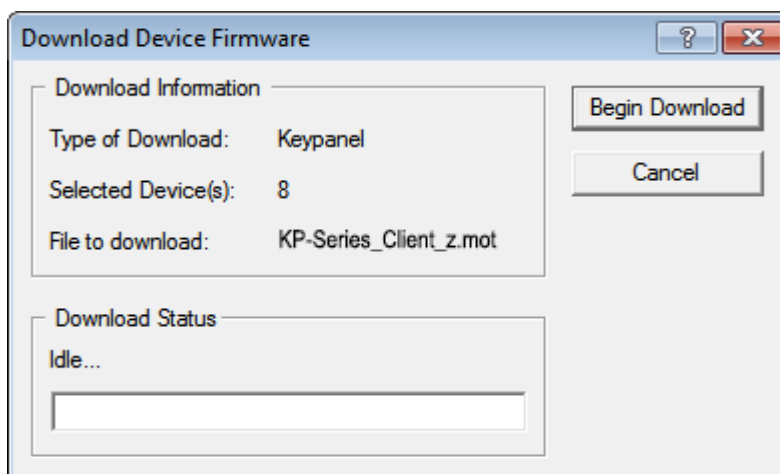

- Click **Begin Download**.
The Download begins and a popup message appears.
- Click **OK**.
The DKP-4016/4016W firmware download finishes.

NOTE: This can take up to 15 minutes to complete if connected via AIO. Use the Keypanel Version Information window to follow the progress of the download (the number and percentage of chunks completed). Also, the firmware progression is displayed on the keypanel display until the download is complete.

NOTE: Once the Boot Loader is finished downloading, it reboots itself and reprograms the flash.



Display the FPGA Version on the Keypanel

To **display the FPGA version currently installed in the keypanel**, do the following:

1. While pressing the Main Vol and Aux Vol encoders on the front of the keypanel at the same time, press the **MENU button**.
The main menu appears in the panel display.
2. Using the left and right arrow buttons, select **Service**.
3. Press the **SEL button**.
The Service menu options appear in the panel display.
4. Using the left and right arrow buttons, select **FPGA Version**.
5. Press the **SEL button**.
Version X.X.X (where X represents the FPGA version numbers) appears in the panel display.

Download and Upgrade the FPGA to the DKP-4016/4016W

There are four (4) phases to upgrading the FPGA on a keypanel:

- Downloading the FPGA firmware to the matrix
- Downloading the FPGA firmware to the keypanel
- Processing the download
- Reprogramming the keypanel

To **download the FPGA to the keypanel**, do the following:

1. Open **AZedit**.
2. From the Status menu, select **Software Versions|Keypanels**.
The Keypanel Version Information window appears.
3. Find the **port number** where the DKP-4016/4016W is assigned.
4. Highlight the **Port** (keypanel) to be updated.
You may select more than one (1) at a time by holding CTRL key down while you select.
5. Right-click the **highlighted selections**.
A popup menu appears.
6. Select **Download Firmware**.
The Firmware Download window appears.
7. Using the browse button, navigate to the **FPGA file** you want to use.

- Click **Open**.

The Download Device Firmware window appears.

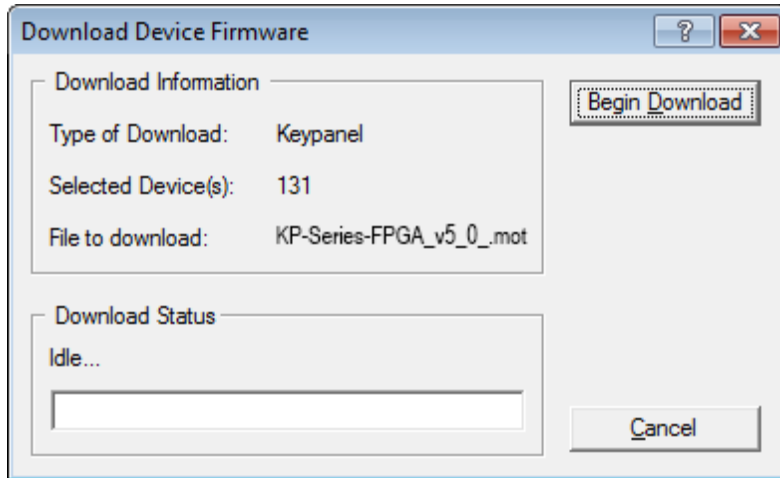

- Click **Begin Download**.

The download begins. A progress bar appears to show the progress of the download.

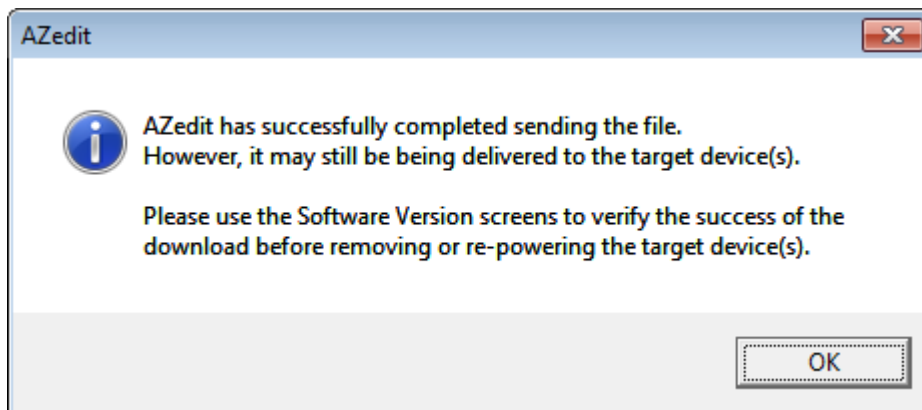

- Click **OK**.

The DKP-4016/4016W firmware download to the Matrix finishes. The Download FPGA Firmware To The Keypanel begins.

11. Verify the Keypanel Version Information window is displaying the **numbers of chunks (of data) transferred to the keypad**.

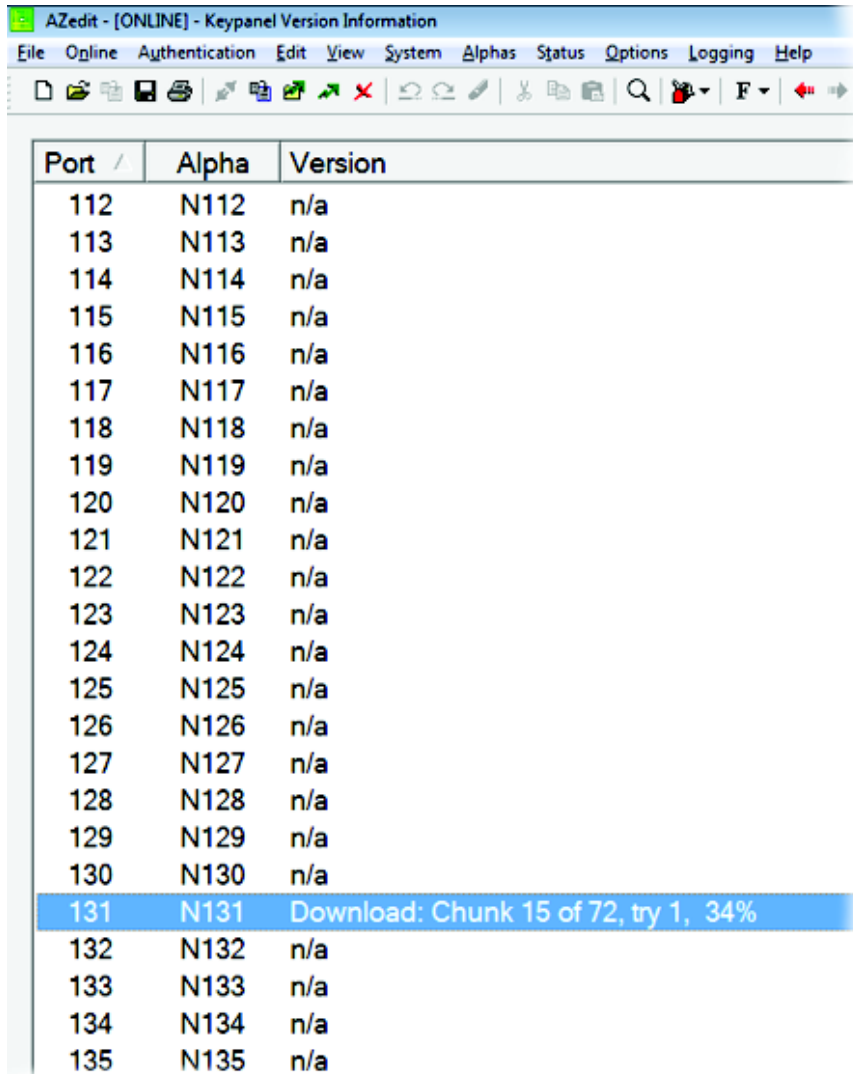

Port /	Alpha	Version
112	N112	n/a
113	N113	n/a
114	N114	n/a
115	N115	n/a
116	N116	n/a
117	N117	n/a
118	N118	n/a
119	N119	n/a
120	N120	n/a
121	N121	n/a
122	N122	n/a
123	N123	n/a
124	N124	n/a
125	N125	n/a
126	N126	n/a
127	N127	n/a
128	N128	n/a
129	N129	n/a
130	N130	n/a
131	N131	Download: Chunk 15 of 72, try 1, 34%
132	N132	n/a
133	N133	n/a
134	N134	n/a
135	N135	n/a

12. Verify the keypad displays the **FPGA Downloading icon with progression bar**.
Once the download is complete, the keypad has to process the downloaded file.

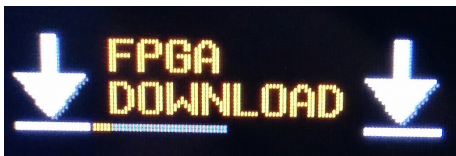

13. Verify the Keypanel Version Information window displays **Processing download** on the keypanel port you chose.

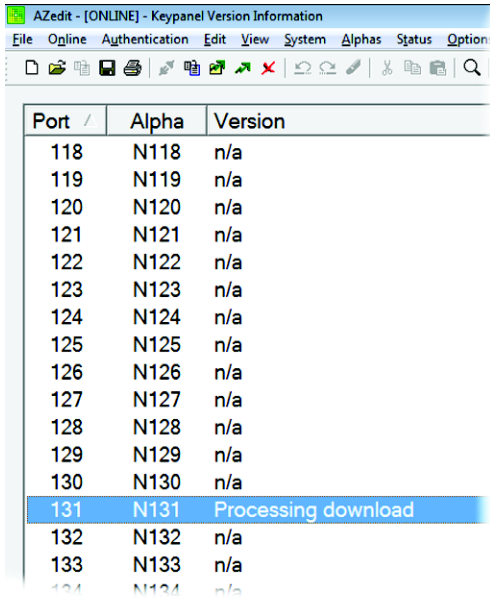

Port /	Alpha	Version
118	N118	n/a
119	N119	n/a
120	N120	n/a
121	N121	n/a
122	N122	n/a
123	N123	n/a
124	N124	n/a
125	N125	n/a
126	N126	n/a
127	N127	n/a
128	N128	n/a
129	N129	n/a
130	N130	n/a
131	N131	Processing download
132	N132	n/a
133	N133	n/a
134	N134	n/a

14. Verify the keypanel displays the **Processing Download icon with progression bar**.



Once the keypanel is finished processing the download, the keypanel begins to reprogram. The keypanel flashes a Reprogramming: Do Not Turn Off icon in the display panel. This can take several minutes.



Once the reprogramming is complete, the keypanel reboots.

Download a Splash Screen

IMPORTANT: The maximum bitmap size is 576x172. If the bitmap is smaller than the full screen dimensions, the keypanel centers the bitmap horizontally and vertically on the display and fills the background with the same color as the pixel in the top left corner of the splash screen.

1. Open **AZedit**.
2. From the Status menu, select **Software Versions|Keypanel**.
The Keypanel Version Information window appears.
3. Find the **port number** where the DKP-4016/4016W is assigned.
4. Highlight the **Port** (keypanel) to be updated.
You may select more than one (1) at a time by holding CTRL key down while you select.
5. Right-click the **highlighted selections**.
A popup menu appears.
6. Select **Download splash screen...**.
The Splash Screen Download window appears.
7. Click **Open**.
The Download Splash Screen File window appears.

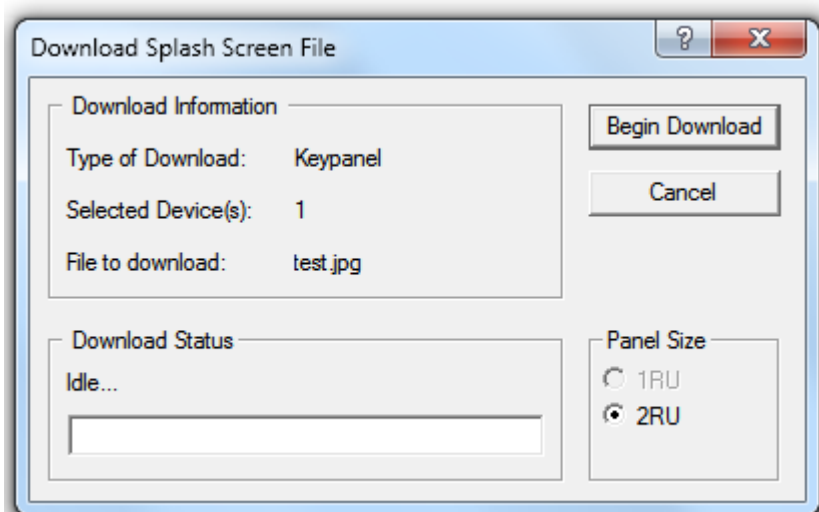

8. In the Panel Size group box, select **2RU**.
9. Click **Begin Download**.
The download begins. A progress bar appears to show the progress of the download. Once the download is complete the Download Splash Screen File window closes.

- Verify the Keypanel Version Information window is displaying the **numbers of chunks (of data) transferred to the keypanel**.

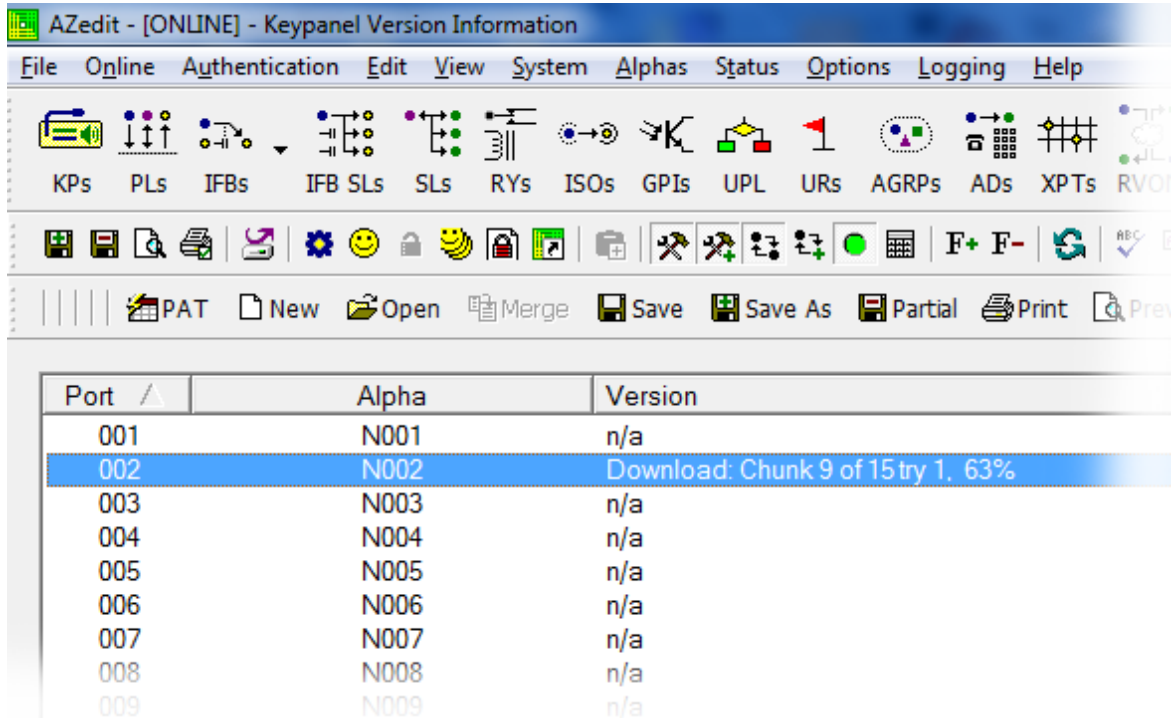

- Verify the keypanel displays the **Splash Screen Downloading icon with progression bar**.
Once the download is complete, the keypanel has to process the downloaded file.

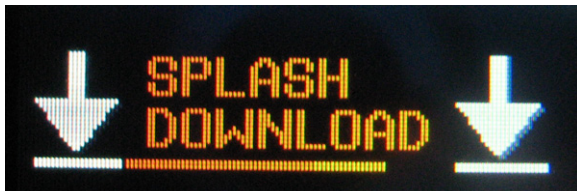

Once the keypanel is finished processing the download, the keypanel begins to reprogram. The keypanel flashes a Reprogramming: Do Not Turn Off icon in the display panel. This can take several minutes.



Once the reprogramming is complete, the keypanel reboots.

Download a Font File

1. Open **AZedit**.
2. From the Status menu, select **Software Versions|Keypanel**.
The Keypanel Version Information window appears.
3. Find the **port number** where the DKP-4016/4016W is assigned.
4. Highlight the **Port** (keypanel) to be updated.
You may select more than one (1) at a time by holding CTRL key down while you select.
5. Right-click the **highlighted selections**.
A popup menu appears.
6. Select **Download font...**
The Font Download window appears.
7. Navigate to the **font file (.kpf)** you want to use.
8. Click **Open**.
The Download Keypanel Font window appears.

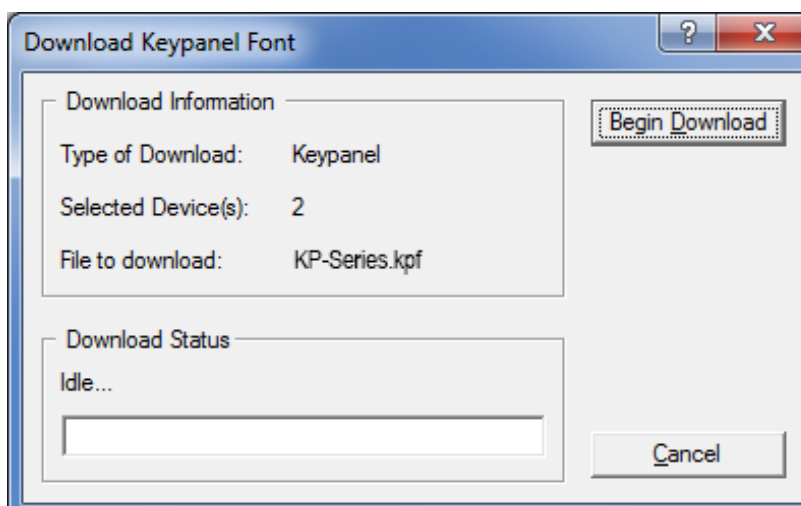

9. Click **Begin Download**.
The download begins. A progress bar appears to show the progress of the download.

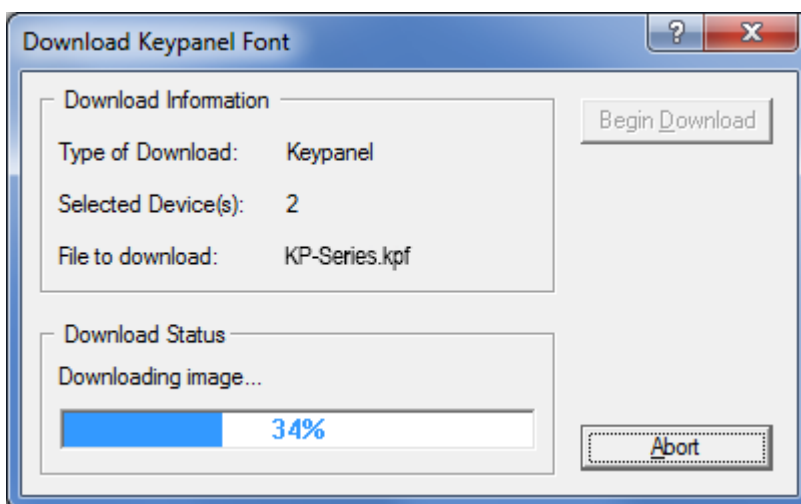

Once the download is complete the Download Keypanel Font window closes.

- Verify the Keypanel Version Information window is displaying the **numbers of chunks (of data) transferred to the keypanel**.

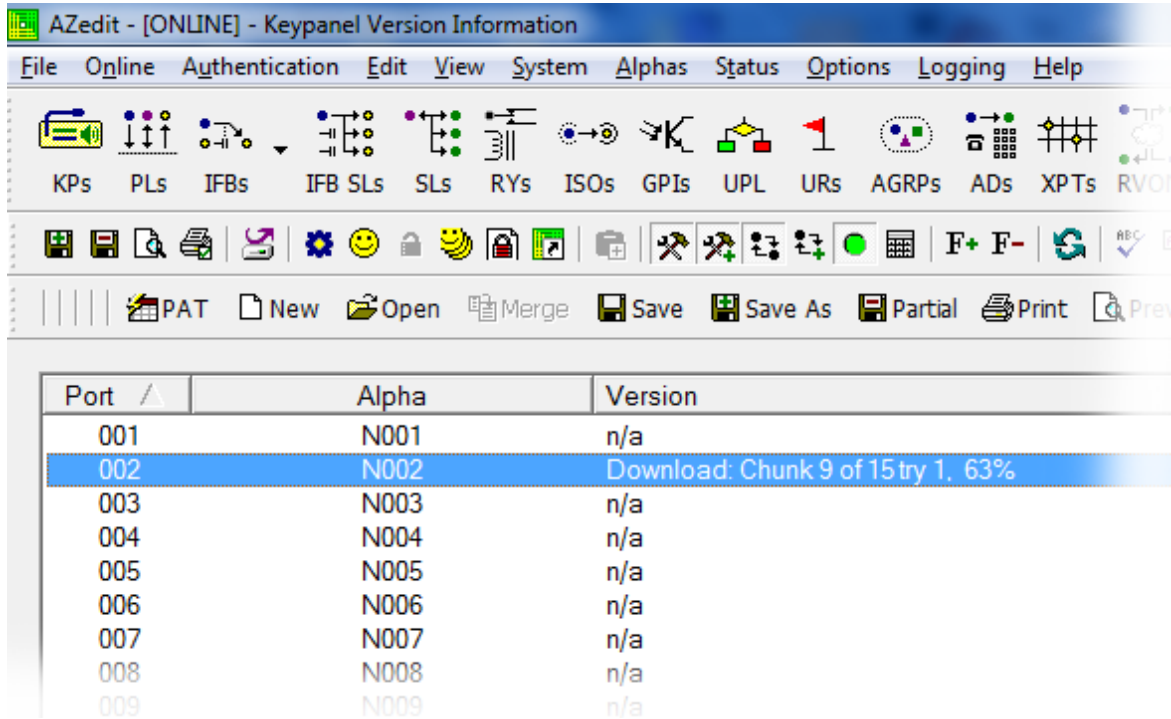

- Verify the keypanel displays the **FONT Downloading icon with progression bar**.
Once the download is complete, the keypanel has to process the downloaded file.

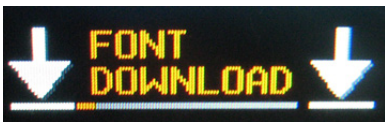

- Verify the Keypanel Version Information window displays **Processing download** on the keypanel port you chose.

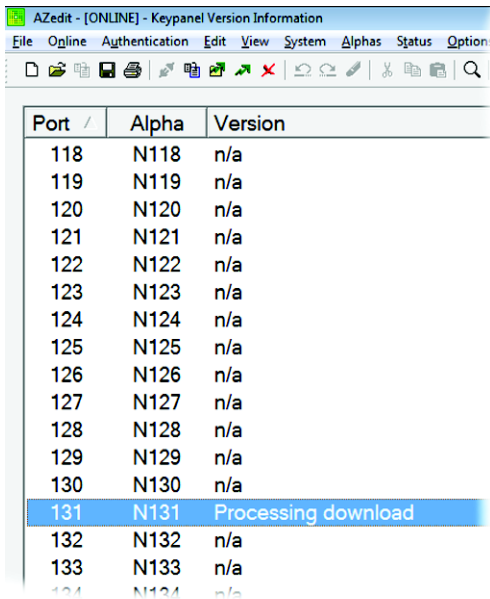

13. Verify the keypanel displays the **Processing Download icon with progression bar**.



Once the keypanel is finished processing the download, the keypanel begins to reprogram. The keypanel flashes a Reprogramming: Do Not Turn Off icon in the display panel. This can take several minutes.



Once the reprogramming is complete, the keypanel reboots.

Download an Icon File

IMPORTANT: The following instructions can be used for either panel icons or tally (key overlay) icons.

To **download an icon file**, do the following:

1. Open **AZedit**.
2. From the Status menu, select **Software Versions|Keypanels**.
The Keypanel Version Information window appears.
3. Find and select the **Port (keypanel)** to be updated.
You may select more than one (1) at a time by holding the CTRL key down while you select.
4. Right-click the **highlighted selection**.
A popup menu appears.

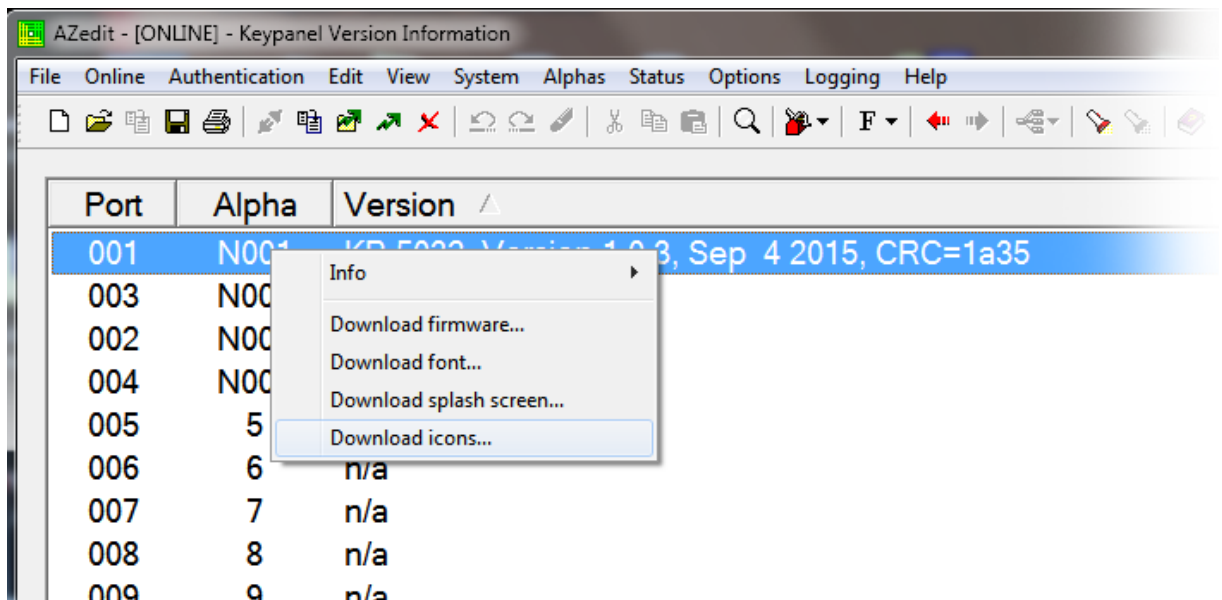

5. Select **Download icons....**
The Icon Download window appears.
6. Navigate to the **icon file (.bmp or .jpg)** you want to use.
7. Click **Open.**
The Download Icon File window appears.

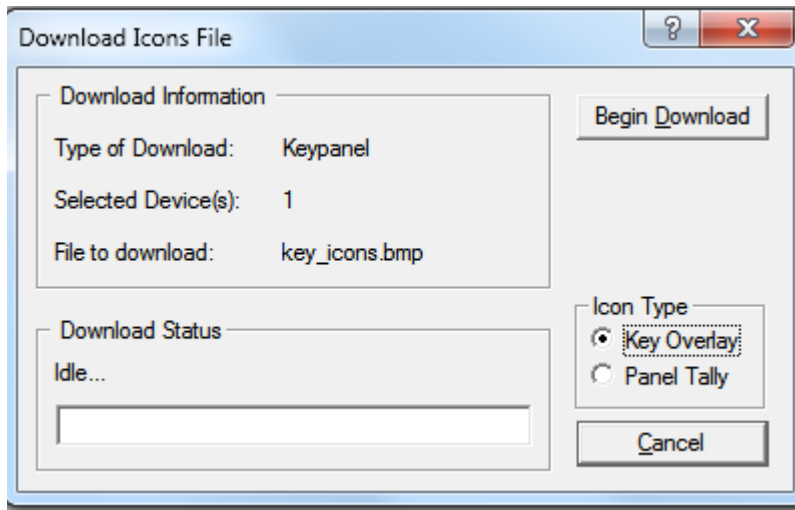

8. Verify the correct **Icon Type radio button** is selected – Key Overlay or Panel Tally radio button.
9. Click **Begin Download.**
The download begins. A progress appears to show the progress of the download. Once the download is complete the Download Keypanel Font window closes.
10. Verify the **Keypanel Version Information window displays the numbers of chunks (of data) transferred to the keypanel.**

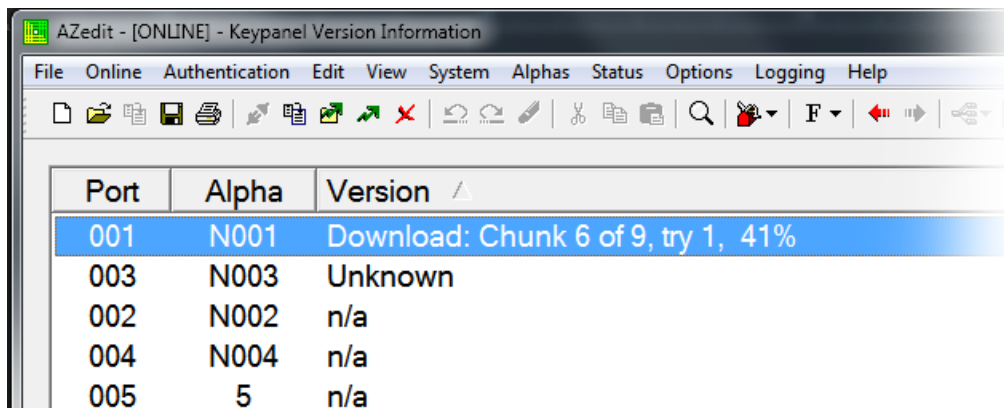

11. Verify the keypanel displays the **ICON Downloading icon** with progression bar.

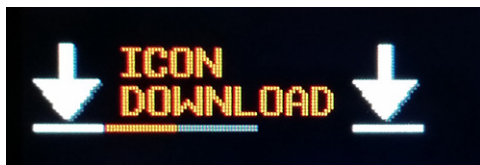

Once the keypanel is finished, it begins to reprogram. The keypanel flashes a Reprogramming: Do Not Turn Off icon in the display panel. This can take several minutes.



Once the reprogramming is complete, the keypanel reboots.

Download User Chimes (Control Package Only)

1. Open **AZedit**.
2. From the Status menu, select **Software Versions|Keypanels**.
The Keypanel Version Information window appears.
3. Find the **port number** where the DKP-4016/4016W is assigned.
4. Highlight the **Port** (keypanel) to be updated.
You may select more than one (1) at a time by holding CTRL key down while you select.
5. Right-click the **highlighted selections**.
A popup menu appears.
6. Select **Download Chime...**
The Font Download window appears.
7. Navigate to the **chime file (.wav or .mp3)** you want to use.
8. Click **Open**.
The Download chime window appears.

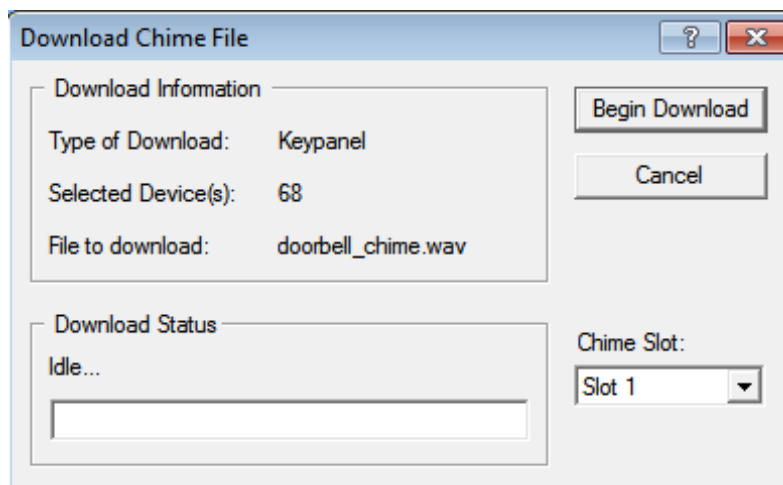

9. Choose a **User Slot**.

10. Click **Begin Download**.

The download begins. A progress bar appears to show the progress of the download.

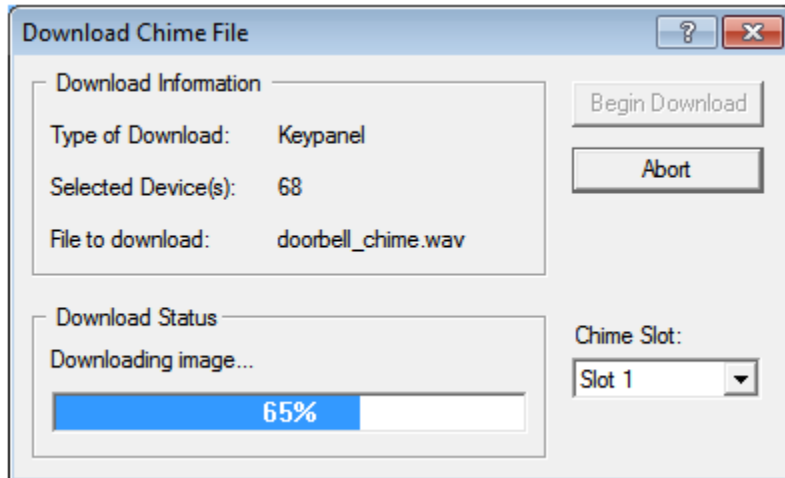

Once the download is complete the Download Keypanel Font window closes.

11. Verify the Keypanel Version Information window is displaying the **numbers of chunks (of data) transferred to the keypanel**.

Port /	Alpha	Version
014	14	n/a
015	15	n/a
016	16	n/a
017	17	n/a
018	18	n/a
019	19	n/a
020	20	n/a
021	21	n/a
022	22	n/a
023	23	n/a
024	24	n/a
025	25	n/a
026	26	n/a
027	27	n/a
028	28	n/a
029	29	n/a
030	30	n/a
031	31	n/a
032	32	Download: Chunk 2 of 18, try 1, 34%
033	33	n/a

12. Verify the keypanel displays the **Chime Download icon with progression bar**.

Once the download is complete, the keypanel has to process the downloaded file.

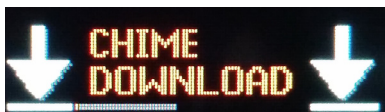

Once the keypanel has finished the download, the keypanel begins to reprogram. The keypanel flashes a Reprogramming: Do Not Turn Off icon in the display panel. This can take several minutes.



Once the reprogramming is complete, the keypanel reboots.

Download Screen Savers (Control Package Only)

IMPORTANT: Recommended screen saver bitmap file size:
DKP-4016 – min 16x16, max 192x130 (WxH)

To **download a screen saver image**, do the following:

1. Open **AZedit**.
2. From the Status menu, select **Software Versions|Keypanels**.
The Keypanel Version Information window appears.
3. Find the **port number** where the DKP-4016/4016W is assigned.
4. Highlight the **Port** (keypanel) to be updated.
You may select more than one (1) at a time by holding CTRL key down while you select.
5. Right-click the **highlighted selections**.
A popup menu appears.
6. Select **Download Screen Saver...**.
The Font Download window appears.
7. Navigate to the **screen saver file (.jpg, .bmp, .gif, .tif, .png)** you want to use.
8. Click **Open**.
The Download chime window appears.

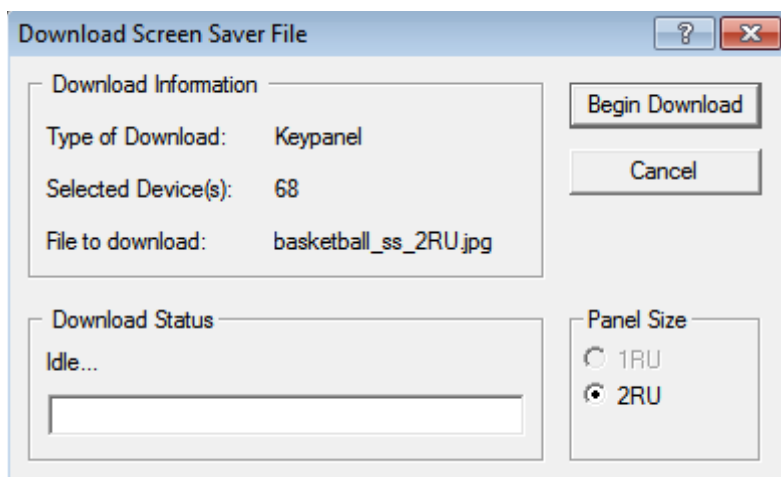

9. From the Panel Size Group Box, select the **2 RU radio button**.

IMPORTANT: If the image is too large for a 1 RU keypanel, AZedit auto-selects 2 RU.

10. Click **Begin Download**.

The download begins. A progress bar appears to show the progress of the download.

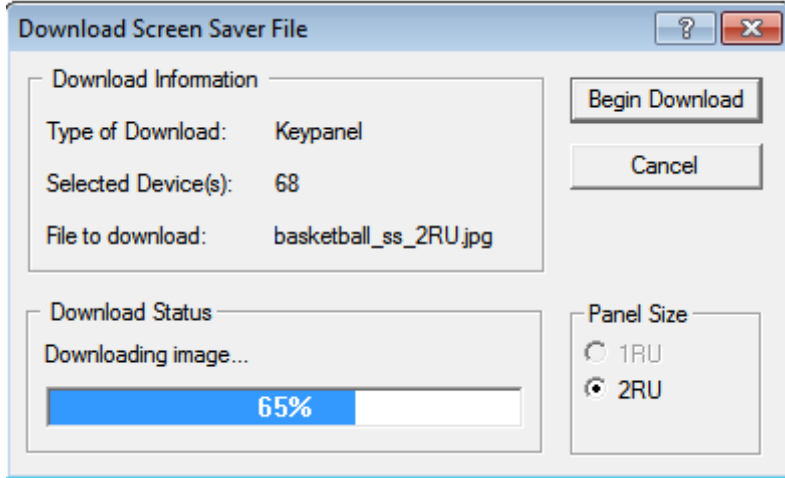

Once the download is complete the Download Keypanel Font window closes.

11. Verify the Keypanel Version Information window is displaying the **numbers of chunks (of data) transferred to the keypanel**.

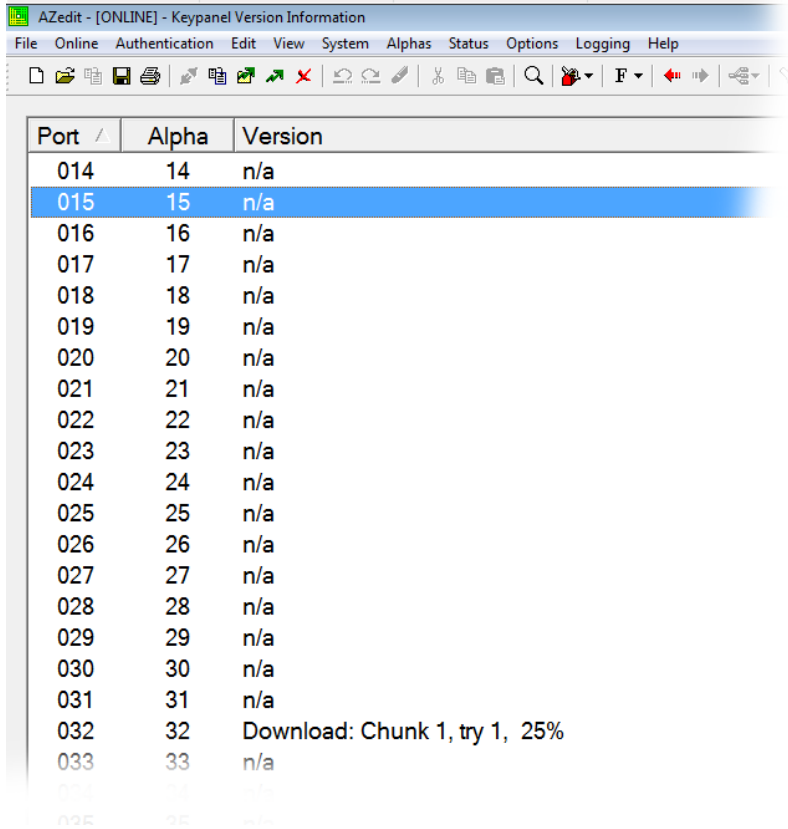

12. Verify the keypanel displays the **Scrn Saver Download icon with progression bar**.

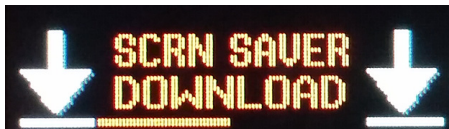

Once the keypanel is finished downloading, the keypanel begins to reprogram. The keypanel flashes a Reprogramming: Do Not Turn Off icon in the display panel. This can take several minutes. Once the reprogramming is complete, the keypanel reboots.



DKP-4016 Menu System

NOTE: A menu system quick reference chart is located at “Keypanel Menu Quick Reference” on page 255.

Main Menu Access

IMPORTANT: For more detailed information on Basic Key operation, see “Menu Navigation and Shaft Encoder Knobs” on page 40.

The **Main Menu** is the top-most level of the menu structure.

Available selections for this menu are:

Audio Options

Display

Key Assign

Key Options

OMNEO Offers

Save Config

Service

To access the main menu structure, do the following:

1. On the keypad keypad, press the **MENU** button.
The Information menu structure displays across the middle of the panel display.



2. Using the arrow buttons on the keypad, navigate through the **menu options**.
3. Press the **SEL** button.
The submenu for the selection appears.

Menu System, Audio Options

Available options for this menu are:

Advanced

Chime

Dim

Ganged Vols

Headset Mic

Headset Spkr

Inputs

Key Volumes

Matrix Out

Max Volume

Mic Gain

Mic Mute

Min Volume

Output Lev

Panel Mic

Preamp Out

Sidetone

Speaker

Tone Gen

VM Options

Audio Options Menu, Advanced

- AEC
- AGC
- Compression
- Filters
- Gating
- Metering
- Mixing
- Mix Mode

AEC

AEC (Acoustic Echo Cancellation) is used to prevent feedback from occurring between the microphone and the speaker. AEC is only available on one (1) microphone; by default, it is enabled on the front panel mic. When the front panel mic is disabled, AEC operates on the rear microphone.

NOTE: AEC is not available for Headset Mics.

Mic Priority

The **Mic Priority** menu is used to select the microphone to enable AEC on when both the front and rear mics are active.

To **configure mic priority on a microphone**, do the following:

1. Starting at the Audio Options|Advanced|AEC menu, select **Mic Priority**.
2. Press the **SEL button**.
Front Mic and Rear Mic appear in the panel display.
3. Using the left and right arrow buttons, select **Front Mic** or **Rear Mic**.
4. Press the **SEL button**.
An arrow appears next to the selected option.

AGC

The **AGC (Automatic Gain Control)** menu is used to set the speed at which a microphone becomes active and the speed at which a sustainable level is achieved through the use of the **Attack** menu and the **Decay** menu. You can set these levels for the front, rear, and headset microphones used with the keypanel.

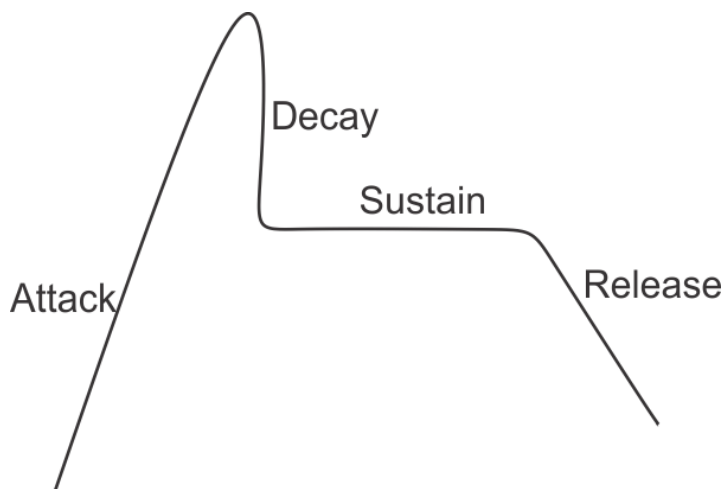

FIGURE 84. Automatic Gain Control Example

Attack

The **Attack** menu item is used to set the speed at which the microphone gets to the activation threshold, the point where the circuit determines if the noise is a voice. The smaller the attack time, the faster the mic turns on.

Available options for this menu are:

0.5ms

1ms (d)

2ms

Decay

The **Decay** menu item is used to set the speed at which the gain transitions to silence during release.

Available options for this menu are:

500ms

750ms (default)

1000ms

To **configure the attack speed for a microphone source**, do the following:

1. Starting at the Audio Options|Advanced|AGC menu, select **Attack**.
2. Press the **SEL button**.
Front Mic, Left Hdst, Rear Mic, and Right Hdst appears in the panel display.
3. Using the arrow buttons, select **Front Mic, Left Hdst, Rear Mic, and Right Hdst**.
4. Press the **SEL button**.
The Fast Attack Speed scroll box appears in the panel display.
5. Using the arrow buttons, select the **Attack speed** you desire.

To **configure the decay speed for a microphone source**, do the following:

1. Starting at the Audio Options|Advanced|AGC menu, select **Decay**.
2. Press the **SEL button**.
Front Mic, Left Hdst, Rear Mic, and Right Hdst appears in the panel display.
3. Using the arrow buttons, select **Front Mic, Left Hdst, Rear Mic, and Right Hdst**.
4. Press the **SEL button**.
The Decay scroll box appears in the panel display.
5. Using the up and down arrow buttons, select the **Decay speed** you desire.

Compression

The **Compression** menu item is used change the audio's gain, meaning audio above the noise gate threshold is changed according to the compression ratio selected. The compression is used to change the dynamic range of the mic input. This means loud sounds are softened; while soft sounds are amplified.

Compression can be applied to the following:

- Front Mic
- Left Headset
- Rear Mic
- Right Hdst

Available options are:

1:1

2:1

3:1(default)

Additional options with purchase of Audio Package:

4:1

5:1

6:1

To **configure compression on a microphone**, do the following:

1. Starting at the Audio Options|Advance menu, select **Compression**.
2. Press the **SEL button**.
Front Mic, Left Hdst, Rear Mic, and Right Hdst appear in the panel display.
3. Using the arrow buttons, select the **microphone source**.
4. Press the **SEL button**.
The Compression Ratio scroll box appears in the panel display.
5. Using the up and down arrow buttons, select the **compression ratio** you want to apply to the microphone source.

Filters

Filters allow you to add a bandpass filter, a preset frequency response (equalization) filter or a notch filter to one (1) or more audio sources.

Bandpass

The **Bandpass** menu is used to enable using bandpass filters as well as set a low and high frequency range where frequencies within the two (2) frequency points are passed and anything outside of the range is rejected.

To **configure a bandpass range for Inputs**, do the following:

1. Starting at the Audio Options|Advanced|Filters menu, select **Bandpass**.
2. Press the **SEL button**.
Inputs and Outputs appears in the panel display.
3. Using the arrow buttons, select **Input**.
4. Press the **SEL button**.
Aux 1, OMNEO 1, and OMNEO 2 appear in the panel display.
Or if the AUDIO package has been purchased, OMNEO 1-8 displays
5. Using the arrow buttons, select either **Aux 1**, **OMNEO 1** or **OMNEO 2** (or OMNEO 1-8, if the audio package is purchased).
6. Press the **SEL button**.
Frequencies and Mode appear in the panel display.
7. Using the arrow buttons, select **Mode**.
Disabled and Enabled appear in the panel display.
8. Using the arrow buttons, select **Enabled**.
9. Press the **SEL button**.
An arrow appears next to the selected option.
10. Press the **CLR** button.
Frequencies and Mode appear in the panel display.
11. Using the arrow buttons, select **Frequencies**.
12. Press the **SEL button**.
The Low Freq scroll box and the High Freq scroll box appear in the panel display.
13. Using the up and down arrow buttons, select the **low frequency** you desire.
14. Using the left and right arrow buttons, select the **high frequency scroll box**.
15. Using the up and down arrow buttons, select the **high frequency** you desire.

To **configure a bandpass range for Outputs**, do the following:

1. Starting at the Audio Options|Advanced|Filters menu, select **Bandpass**.
Inputs and Outputs appears in the panel display.
2. Using the arrow buttons, select **Output**.
3. Press the **SEL button**.
Left Hdst, Matrix Out, OMNEO 1, OMNEO 2, Preamp Out, and Right Hdst appear in the panel display.
Or if the AUDIO package has been purchased, OMNEO 1-8 displays
4. Using the arrow buttons, select the **output** you desire to modify.

If Left Hdst or Right Hdst is chosen:

- a. Press the **SEL button**.
Both, Left Chan, and Right Chan appear in the panel display.
- b. Using the left and right arrow buttons, select either **Both**, **Left Chan**, or **Right Chan**.
5. Press the **SEL button**.
Frequencies and Mode appear in the panel display.
6. Using the arrow buttons, select **Mode**.
Disabled and Enabled appear in the panel display.

7. Using the arrow buttons, select **Enabled**.
8. Press the **SEL button**.
An arrow appears next to the selected option.
9. Press the **CLR button**.
Frequencies and Mode appear in the panel display.
10. Using the left and right arrow buttons, select **Frequencies**.
11. Press the **SEL button**.
The Low Freq scroll box and the High Freq scroll box appear in the panel display.
12. Using the up and down arrow buttons, select the **low frequency** you desire.
13. Using the left and right arrow buttons, select the **high frequency scroll box**.
14. Using the up and down arrow buttons, select the **high frequency** you desire.

Equalization

Equalization allows the user to select predefined settings that modify the frequency envelope of an audio channel. This is a 5-band equalizer. Each preset provides a different EQ to be applied to the audio. To view all of the bands, see “Adjustable 5-Band Equalization – Audio Package Only” on page 183.

Available selections for this menu are:

<i>Default</i>	0 dB (15Hz–20kHz)
<i>Hiss Reduction</i>	0 dB (15Hz–2kHz) -6 dB (2kHz–12.6kHz)
<i>Rumble Reduction</i>	0 dB (50Hz–20kHz)
<i>Noise Reduction</i>	0 dB (50Hz–2kHz) -6 dB (2kHz–8kHz) -80dB (8kHz–12.6kHz)

To **configure a preset frequency response for an input**, do the following:

1. Starting at the Audio Options|Advanced|Filters menu, select **Equalization**.
Inputs and Outputs appears in the panel display.
2. Using the arrow buttons, select either **Input**.
3. Press the **SEL button**.
Front Mic, Left Hdst, Matrix In, Rear Mic, and Right Hdst appear in the panel display.
4. Using the arrow buttons, select either **Front Mic, Left Hdst, Matrix In, Rear Mic, and Right Hdst**.
5. Press the **SEL button**.
Mode and Presets appear in the panel display.
6. Using the arrow buttons, select **Mode**.
Disabled and Enabled appear in the panel display.
7. Using the arrow buttons, select **Enabled**.
8. Press the **SEL button**.
An arrow appears next to the selected option.
9. Press the **CLR button**.
Mode and Presets appear in the panel display.
10. Using the arrow buttons, select **Presets**.
11. Press the **SEL button**.
Default, Hiss Reduction, and Rumble Reduction appear in the panel display.
12. Using the arrow buttons, select **Default, Hiss Reduction, or Rumble Reduction**.
13. Press the **SEL button**.
An arrow appears next to preset selected.

To **configure a preset frequency response for an output**, do the following:

1. Starting at the Audio Options|Advanced|Filters menu, select **Equalization**.
Inputs and Outputs appears in the panel display.
2. Using the arrow buttons, select either **Output**.
3. Press the **SEL button**.
Left Spkr and Right Spkr appear in the panel display.
4. Using the arrow buttons, select either **Front Spkr** or **Right Spkr**.
5. Press the **SEL button**.
Mode and Presets appear in the panel display.
6. Using the arrow buttons, select **Mode**.
Disabled and Enabled appear in the panel display.
7. Using the arrow buttons, select **Enabled**.
8. Press the **SEL button**.
An arrow appears next to the selected option.
9. Press the **CLR button**.
Mode and Presets appear in the panel display.
10. Using the arrow buttons, select **Presets**.
11. Press the **SEL button**.
Default, Hiss Reduction, and Rumble Reduction appear in the panel display.
12. Using the arrow buttons, select **Default**, **Hiss Reduction**, or **Rumble Reduction**.
13. Press the **SEL button**.
An arrow appears next to preset selected.

Adjustable 5-Band Equalization – Audio Package Only

Included in the purchased audio package, is an adjustable 5-band equalizer giving you the ability to adjust the low and high frequency cutoff filters and the gain for each band. This feature is in addition to the preset equalization settings that comes standard on the keypad.

1		2		3		4		5	
low	high	low	high	low	high	low	high	low	high
15.6Hz	125Hz	125Hz	500Hz	500Hz	2000Hz	2000Hz	8000Hz	8000Hz	12.6kHz
31.3Hz									15.8kHz
50.0Hz									20.0kHz

- Band 1 has three options for low cut-off frequency
- Bands 2, 3, and 4 have fixed frequencies
- Band 5 has three options for high cut-off frequency independent of the low frequency setting

To **adjust the low and high frequency cutoff filters for Inputs**, do the following:

1. Starting at the Audio Options|Advanced|Filters menu, select **Equalizer**.
2. Press the **SEL button**.
Inputs and Outputs appears in the panel display.
3. Using the arrow buttons, select **Input**.
4. Press the **SEL button**.
Front Mic, Left Hdst, Matrix In, Rear Mic and Right Hdst appear in the panel display.
5. Using the arrow buttons, select the **input** you want to adjust.
6. Press the **SEL button**.
Frequencies, Gains, Mode and Presets appear in the panel display.
7. Using the arrow buttons, select **Frequencies**.

8. Press the **SEL button**.
The Low Freq scroll box and the High Freq scroll box appear in the panel display.
9. Using the up and down arrow buttons, select the **low frequency** you desire.
10. Using the left and right arrow buttons, select the **high frequency scroll box**.
11. Using the up and down arrow buttons, select the **high frequency** you desire.
12. Repeat **steps 4 through 11** for each input.

To **adjust the low and high frequency cutoff filters for Outputs**, do the following:

1. Starting at the Audio Options|Advanced|Filters menu, select **Equalizer**.
2. Press the **SEL button**.
Inputs and Outputs appears in the panel display.
3. Using the arrow buttons, select **Output**.
4. Press the **SEL button**.
Front Spkr and Rear Spkr appear in the panel display.
5. Using the arrow buttons, select **either Front Spkr or Rear Spkr**.
6. Press the **SEL button**.
Frequencies, Gains, Mode and Presets appear in the panel display.
7. Using the arrow buttons, select **Frequencies**.
8. Press the **SEL button**.
The Low Freq scroll box and the High Freq scroll box appear in the panel display.
9. Using the up and down arrow buttons, select the **low frequency** you desire.
10. Using the left and right arrow buttons, select the **high frequency scroll box**.
11. Using the up and down arrow buttons, select the **high frequency** you desire.
12. Repeat **steps 4 through 11** for each output.

To **configure the 5-band gain for inputs**, do the following:

1. Starting at the Audio Options|Advanced|Filters menu, select **Equalization**.
2. Press the **SEL button**.
Inputs and Outputs appears in the panel display.
3. Using the arrow buttons, select **Input**
4. Press the **SEL button**.
Front Mic, Left Mic, Matrix In, Rear Mic, and Right Hdst appear in the panel display.
5. Using the left and right arrow buttons, select the **input** desired.
6. Press the **SEL button**.
Frequencies, Gains, Mode, and Presets appear in the panel display
7. Using the left or right arrow buttons, select **Gains**.
8. Press the SEL button.
The 1: through 5: band scroll boxes appear in the panel display.
9. Using the up and down arrow buttons, select the **gain level** you desire for Band 1.
10. Using the left and right arrow buttons, select the **Band 2 scroll box**.
11. Using the up and down arrow buttons, select the **gain level** you desire Band 2.
12. Repeat **setting the gain levels on the remaining bands**.
13. Repeat **steps 4 through 11** for each input, desired.

To **configure the 5-band gain for outputs**, do the following:

1. Starting at the Audio Options|Advanced|Filters menu, select **Equalization**.
2. Press the **SEL button**.
Inputs and Outputs appears in the panel display.
3. Using the arrow buttons, select **Output**

4. Press the **SEL button**.
Front Spkr and Rear Spkr appear in the panel display.
5. Using the left and right arrow buttons, select either **Front Spkr** or **Rear Spkr**.
6. Press the **SEL button**.
Frequencies, Gains, Mode, and Presets appear in the panel display
7. Using the left or right arrow buttons, select **Gains**.
8. Press the **SEL button**.
The 1: through 5: band scroll boxes appear in the panel display.
9. Using the up and down arrow buttons, select the **gain level** you desire for Band 1.
10. Using the left and right arrow buttons, select the **Band 2 scroll box**.
11. Using the up and down arrow buttons, select the **gain level** you desire Band 2.
12. Repeat **setting the gain levels on the remaining bands**.
13. Repeat **steps 4 through 11** for each input, desired.

Notch

The **Notch** menu allows you to add a notch filter to the Matrix In source - either AIO or OMNEO channel 1. This can be useful when the keypad data port signal is being heard in the audio line due to cable routing problems.

By default, the notch filter is set to *Disabled*.

Available options for this menu are:

Disabled

Narrow 9500hz–9700Hz (200Hz band)

Default 9450hz–9750Hz (300Hz band)

Wide 9400hz–9800Hz (400Hz band)

Gating

Gating (also called VOX) allows you to minimize or eliminate background noise problems by shutting off an audio source when the audio level drops below a certain threshold.

Gating can be applied to the following:

Aux 1

Front Mic

Left Hdst

Matrix In

OMNEO 1

OMNEO 2 (OMNEO 1-8 appear if Audio Package is installed)

Rear Mic

Right Hdst

The range for the gating threshold is *-17dB* to *+18dB*, and *Disabled*.
By default, the gating threshold is set to *Disabled*.

Nominal inputs are as follows:

<i>AUX 1</i>	<i>8dBu</i>
<i>Headset Mics</i>	<i>-50dBu</i>
<i>Matrix In</i>	<i>8dBu</i>
<i>Panel Mics</i>	<i>-42.5dBu</i>
<i>OMNEO 1-2¹</i>	<i>8dBu</i>

To **configure gating on the keypad**, do the following:

1. Starting at the Audio Options|Advanced menu, select **Gating**.
2. Press the **SEL button**.
Aux 1, Front Mic, Left Hdst, Matrix In, OMNEO 1, OMNEO 2, Rear Mic, and Right Hdst appear in the panel display. (OMNEO 1-8 appears if Audio Package is installed)
3. Using the left or right arrow buttons, select **Aux 1, Front Mic, Left Hdst, Matrix In, OMNEO 1, OMNEO 2, Rear Mic, or Right Hdst.**(*OMNEO 1-8 appears Audio Package is installed*)
4. Press the **SEL button**.
The Threshold scroll menu appears.
5. Using the up and down arrow buttons, select the **threshold** you desire.
6. Press **BACK** to go to the previous menu item
OR
Press and hold **CLR** to exit the menu structure.

Metering

Metering allows you to monitor an audio source connected to the keypad. The energy of the incoming audio is split into five (5) bands and displayed on the left side of the keypad when enabled.

The decibels display range is from 28dB below nominal to 8dB above nominal
The bands are defined as:

<i>Band 1</i>	<i>100 Hz to 400 Hz</i>
<i>Band 2</i>	<i>400 Hz to 800 Hz</i>
<i>Band 3</i>	<i>800 Hz to 1.6 kHz</i>
<i>Band 4</i>	<i>1.6 kHz to 3.2 kHz</i>
<i>Band 5</i>	<i>3.2 kHz to 15 kHz</i>

NOTE: Only one (1) channel can be metered at a time.

1. *OMNEO 1-8 appears if Audio Package is installed.*

You can enable metering on:

Aux 1

Front Mic

Left Hdst

Matrix In

None (default)

OMNEO 1¹

OMNEO 2¹

Panel Mic

Rear Mic

Right Hdst

To **enable metering**, do the following:

1. Starting at the Audio Options|Advanced menu, select **Metering**.
2. Press the **SEL button**.
Aux 1, Matrix In, None, Front Mic, Left Hdst, None, OMNEO 1, OMNEO 2, Rear Mic, and Right Hdst appear in the panel display. (OMNEO 1-8 appears if Audio Package is installed)
3. Using the arrow key, select **Aux 1, Matrix In, None, Front Mic, Left Hdst, OMNEO 1, OMNEO 2, Rear Mic, or Right Hdst** (*OMNEO 1-8 appears if Audio Package is installed*).
4. Press the **SEL button**.
An arrow appears next to the selected option.

1. *OMNEO 1-8 appears if Audio Package is installed*

Mixing

Mixing allows you to route selected audio signals to the following destinations:

- To Matrix
- Left Headphone
- Front Right Headphone
- Front Speaker
- Mic Preamp Out
- OMNEO 1
- OMNEO 2
- Rear Speaker
- Rear Left Headphone
- Right Headphone

(OMNEO 1-8 appears if the Audio Package is purchased)

IMPORTANT: If OMNEO is enabled, OMNEO 1 is not available because it is acting as the Matrix. On the other hand, if AIO is enabled, OMNEO 1 and OMNEO 2 are both available as auxiliary channels.

By default, the microphone signals are routed to the matrix. The matrix signal is routed to the front speaker and to the left and right channels of both headphones. These defaults can be changed via the Audio Options sub-menus for Panel Mic, Headset Mic, Speaker, and Headset Speaker.

Available options for this menu are:

Left Hdst

Front Spkr

OMNEO 1

OMNEO 2

Preamp out

Right Hdst

Rear Spkr

To Matrix

NOTE: OMNEO 1-8 appears only if the Audio Package is installed.

TABLE 9. Resources Table

Destination	Source							
	Front Panel Mic	Matrix Audio In	Left Headset Mic	Right Headset Mic	Rear Panel Mic	Aux 1	OMNEO 1	OMNEO 2
Matrix OUT	a	X	a	a	a	X	X	X
Front Speaker	X	b	X	X	X	X	X	X
Left Headset Left	X	b	X	X	X	X	X	X
Left Headset Right	X	b	X	X	X	X	X	X
Right Headset Left	X	b	X	X	X	X	X	X
Right Headset Right	X	b	X	X	X	X	X	X
Rear Speaker	X	b	X	X	X	X	X	X
Mic OUT	a	X	a	a	a	X	X	X
OMNEO ^c Ch 1	X	X	X	X	X	X	X	X
OMNEO Ch 2	X	X	X	X	X	X	X	X

- Mic inputs cannot be mixed to the Matrix or preamp outputs using this menu. To mix mic inputs to the matrix output or preamp output, use the Panel Mic and Headset Mic menus.
- The Matrix input cannot be mixed to speaker or headset outputs using this menu. To mix Matrix In to speakers or headsets, use the Speaker and Headset Spkr menus.
- OMNEO 1-8 appears only if the Audio Package is installed.

To **configure mixing**, do the following:

- Starting at the Audio Options|Advanced menu, select **Mixing**.
- Press the **SEL button**.
Front Left Hdst, Front Spkr, OMNEO 1, OMNEO 2, Preamp Out, Right Hdst, Rear Spkr, and To Matrix appear in the panel display.
- Using the left or right arrow buttons, select a the **destination** to mix to (or the destination to which the sources will be mixed).

NOTE: If Left Hdst or Right Hdst is chosen, an additional step of choosing Both, Left Chan, or Right Chan is required.

- Press the **SEL button**.
If Front Spkr, Rear Spkr, Left Hdst or Right Hdst is selected Aux 1, Left Hdst, Front Mic, OMNEO 1, OMNEO 2, Rear Mic, and Right Hdst appears in the panel display.
OR
If OMNEO 1 or OMNEO 2 is selected Aux 1, Left Hdst, Front Mic, Matrix In, OMNEO 1, OMNEO 2, Rear Mic, and Right Hdst appears in the panel display.
- Using the left or right arrow buttons, select the **input** to mix to the selected output.
- Press the **SEL button**.
An arrow appears next to the selection.

NOTE: Repeat steps 5 and 6 to select additional inputs to mix to the selected output.

Mix Mode

The **Mix Mode** menu is used to control whether mixes made to the speakers and headsets are muted when they are not active.

Available options for this menu are:

<i>Aux Mixes Switched (default)</i>	Aux inputs mixed to matrix out, preamp out, speakers or headsets are only heard when the panel is in the appropriate headset or speaker mode.
<i>Mixes always active</i>	Aux inputs mixed to speakers or headset are always heard, regardless of whether the panel is in headset or speaker mode.

To **configure Mix Mode**, do the following:

1. Starting at the Audio Options|Advanced menu, select **Mix Mode**.
2. Press the **SEL button**.
Aux Mixes Switched and Mixes Always Active appear in the panel display.
3. Using the left or right arrow buttons, select the **mix mode** you desire.
4. Press the **SEL button**.
An arrow appears next to the selection.

Noise Gate

The **Noise Gate** menu is used to enable or disable the audio level at which the mic turns on. When noise gate is enabled, microphone noise gate is set to -72dBu; when the noise gate is disabled, the microphone is always on.

To **enable/disable noise gate**, do the following:

1. Starting at the Audio Options|Advanced menu, select **Noise Gate**.
2. Using the left or right arrow keys, move to the **Mic scroll box**.
3. Using the up or down arrow keys, select the **Front Mic, Left Mic, Rear Mic, or Right Mic**.
4. Using the left or right arrow keys, move to the **State scroll box**.
5. Using the up or down arrow keys, select **Disable** or **Enable**.

Noise Gate – Audio Package Only

If you have purchased the Audio Package for the DKP-4016, you have the ability to adjust the noise gate, giving you more flexibility configuring the input gate levels for each device.

Available options are: *Disabled, -87 dBu, -84 dBu, -81 dBu, -78 dBu, -75 dBu, -72 dBu, -69 dBu, -66 dBu, -63 dBu, -60 dBu, -57 dBu, -54 dBu, -51 dBu, -48 dBu, -48 dBu, or -42 dBu.*

To **adjust the noise gate**, do the following:

1. Starting at the Audio Options|Advanced menu, select **Noise Gate**.
2. Press the **SEL button**.
Front Mic, Left Hdset, Rear Mic, and Right Hdset appear in the panel display.
3. Using the left or right arrow keys, select the **input** you want to apply the noise gate.
4. Press the **SEL button**.
The Noise Gate scroll list appears in the panel display.
5. Using the up and down arrow keys, select the **gate level** you desire.

Audio Options Menu, Chime

The **Chime** menu is used to set the volume for each of the built-in chimes, as well as to enable or disable preview of chimes during chime selection in this menu and others that reference chimes.

Available configurable options for this menu are:

<i>Preview</i>	When enabled, a preview of the chime is played each time a new chime is selected or while the volume is being adjusted, so you can listen to what it sounds like.
<i>Chime</i>	Allows the user to select between 12 system chimes. An additional four User chimes are added when the Audio package is installed.
<i>Volume</i>	Controls the volume of the chime. This field ranges from <i>-60dB to 10dB</i> . The default for this field is <i>-20dB</i> .

To **configure Chime on the keypad**, do the following:

1. Starting at the Audio Options menu, select **Chime**.
2. Press the **SEL button**.
The Preview, Chime, and Volume scroll boxes appear in the panel display.
3. Using the up or down arrow buttons, select **Yes** or **No** for Preview.
4. Using the left or right arrow buttons, select **Chime**.
5. Using the up or down arrow buttons, select the **system chime desired**.
6. Using the left or right arrow buttons, select **Volume**.
7. Using the up or down arrow buttons, select the **volume** you want the chime to sound.

Audio Options Menu, Dim

To **configure Dim on the keypad**, do the following:

1. Starting at Audio Options, select **Dim**.
2. Press the **SEL button**.
Headset and Speaker appear in the panel display.
3. Using the left or right arrow buttons, select **Headset** or **Speaker**.
4. Press the **SEL button**.
Front and Rear (or left and right if Hdst was chosen) appear in the panel display.
5. Using the left or right arrow buttons, select **Front** or **Rear** (if Hdst was chosen, Left or Right).
6. Press the **SEL button**.
The Dim Amount scroll box appears.
7. Using the up or down arrow buttons, select the **Dim Amount** you desire.

Audio Options Menu, Ganged Vols

Ganged Vols is used to set what happens when adjusting the volume for a ganged channel pair when the volumes are not identical and one (1) of the volumes reaches the minimum or maximum level.

Available options:

<i>Disappearing Mode</i>	Allows adjustments to continue when one of the volumes of the ganged pair hits a limit. This setting adjusts the volume difference until the difference or offset between the volumes disappears.
<i>Fixed Offset Mode</i>	Prevents adjustments to continue when one of the volumes of the ganged pair hits a limit. This setting maintains the difference between the two volumes.

To **configure ganged volume**, do the following:

1. Starting at Audio Options, select **Ganged Vols**.
2. Press the **SEL button**.
Disappearing and Fixed Offset appear in the panel display.
3. Using the left or right arrow buttons, select either **Disappearing** or **Fixed Offset**.
4. Press the **SEL button**.
An arrow appears next to the selected option.

Audio Options Menu, Headset Mic

The **Headset Mic** option allows the user to configure where audio is coming from and the type of microphone being used.

By default, if no headset is detected, the headset mic input is muted to avoid allowing noise to get to the system. This feature can be disabled.

Auto-Mute

The **Auto-Mute** option is used to automatically mute the Mic Input when a headset mic is not detected.

Available selections for the Auto-mute menu are:

Disabled

Enabled

Mode

Available selections for the Mode menu are:

Disabled

Enabled

Switched (d) When set to Switched, the state of the Headset Mic is controlled by the Mic Sel key.

Type

Available selections for the Type menu are:

Auto-Detect (default) The keypad automatically detects the type of microphone connected.

Dynamic

Electret

To **configure the Headset Mic Auto-mute**, do the following:

1. Starting at the Audio Options menu, select **Headset Mic**.
2. Press the **SEL button**.
Front and Rear appear in the panel display.
3. Using the right or left arrow buttons, select **Left** or **Right**.
4. Press the **SEL button**.
Auto-Mute, Mode and Type appear in the panel display.
5. Using the right or left arrow buttons, select **Auto-Mute**.
6. Press the **SEL button**.
Disabled and Enabled appear in the panel display.
7. Using the right or left arrow buttons, select **Disabled** or **Enabled**.
8. Press the **SEL button**.
An arrow appears next to the selected option.

To **configure the Headset Mic Mode**, do the following:

1. Starting at the Audio Options menu, select **Headset Mic**.
2. Press the **SEL button**.
Front and Rear appear in the panel display.
3. Using the right and left arrow buttons, select **Left** or **Right**.
4. Press the **SEL button**.
Auto-Mute, Mode and Type appear in the panel display.
5. Using the right and left arrow buttons, select **Mode**.
6. Press the **SEL button**.
Disabled, Enabled, and Switched appear in the panel display.
7. Using the right and left arrow buttons, select **Disabled**, **Enabled**, or **Switched**.
8. Press the **SEL button**.
An arrow appears next to the selected option.

To **configure the Headset Mic Type**, do the following:

1. Starting at the Audio Options menu, select **Headset Mic**.
2. Press the **SEL button**.
Front and Rear appear in the panel display.
3. Using the right and left arrow buttons, select **Left** or **Right**.
4. Press the **SEL button**.
Auto-Mute, Mode and Type appear in the panel display.
5. Using the right and left arrow buttons, select **Type**.
6. Press the **SEL button**.
Auto-Detect, Dynamic, and Electret appear in the panel display.
7. Using the right and left arrow buttons, select **Auto-Detect**, **Dynamic**, or **Electret**.
8. Press the **SEL button**.
An arrow appears next to the selected option.

Audio Options Menu, Headset Speaker

The **Headset Spkr** menu option is used to control the headset detection functions: auto-transfer, which is used to detect if a headset is present and mode, which determines when and where audio is heard. Also from this menu, the Main shaft encoder is defined how to control the left and right speakers.

Volume Control

Available selections for the Volume Control menu are:

Ganged The volume controls are tied to each other, only one knob is turned to adjust volume levels. The volume of both left and right headset speakers are controlled together.

Individual The volume controls are separate to each other.

NOTE: If you gang speakers and/or headset volumes, you may see a split volume bar if the left and right have different volumes with ganging is enabled. The front speaker or left headset is the top portion of the bar, while the bottom portion of the bar is the rear speaker or right headset volume.

To **define how the Main Volume shaft encoder controls the volume for the left and right headset speakers**, do the following:

1. Starting at the Audio Options|Headset Spkr menu, select **Volume Control**.
2. Press the **SEL button**.
Ganged and Individual appear in the panel display.
3. Using the left or right arrow buttons, select **Ganged** or **Individual**.
4. Press the **SEL button**.
An arrow appears next to the selected option.

Auto-Transfer

Available selections for the Auto-transfer menu are:

Disabled

Enabled When enabled, the keypad automatically enters or leaves headset mode when a headset is plugged in or removed.

To **configure the Headset Auto-Transfer function**, do the following:

1. Starting at the Audio Options|Headset Spkr menu, select **Left** or **Right**.
2. Press the **SEL button**.
Auto-Transfer and Mode appear in the panel display.
3. Using the left or right arrow buttons, select **Auto-Transfer**.
4. Press the **SEL button**.
Disabled and Enabled appear in the panel display.
5. Using the left or right arrow buttons, select **Disabled** or **Enabled**.
6. Press the **SEL button**.
An arrow appears next to the selected option.

Mode

Available selections for the Mode menu are:

Always On

Disabled

Switched

When set to Switched, the state of the Headset Spkr is controlled by the Mic Sel key.

NOTE: The default for the left and right headset is *Always On*.

To **configure the Headset Spkr Mode**, do the following:

1. Starting at the Audio Options|Headset Spkr menu, select **Left** or **Right**.
2. Press the **SEL button**.
Auto-Transfer and Mode appear in the panel display.
3. Using the left or right arrow buttons, select **Mode**.
4. Press the **SEL button**.
Both, Left Chan, and Right Chan appear in the panel display.
5. Using the left or right arrow buttons, select the **mode** you want.
6. Press the **SEL button**.
Always On, Disabled, and Switched appear in the panel display.
7. Using the left or right arrow buttons, select the **mode**.
8. Press the **SEL button**.
An arrow appears next to the selected option.

Audio Options Menu, Inputs

The **Inputs** menu is used to enable or disable volume control for audio inputs through the front panel encoder. The DKP-4016 has four (4) Input connectors on the back panel of the unit. By default, all inputs are enabled. This means the inputs are visible as inputs in the Mixing menu and (if mixed somewhere) can be selected for volume control.

If disabled, the inputs are not visible in the mixing menu and cannot be selected for volume control.

NOTE: Disabling an input does not undo any of the mixes you had previously established in the Mixing menu; however, it hides access to volume control of this input. This is useful if you want to set the matrix input volume, and then want to disable the volume control so users cannot adjust the Matrix volume.

To **enable or disable an input**, do the following:

1. Starting at the Audio Options|Inputs menu, select **Aux 1, Matrix In, OMNEO1** or **OMNEO2** (OMNEO 3-8 available, if licensed).
2. Press the **SEL button**.
Disabled and Enabled appear in the panel display.
3. Using the arrow buttons, select **Enabled** to enable the selected Input.
OR
Using the arrow buttons, select **Disabled** to disable the selected Input

Audio Options Menu, Key Volumes

The **Key Volumes** menu is used to enable or disable the adjusting of crosspoint listen gains. If key volumes are enabled, the user can adjust the list gains for Matrix crosspoints from the keypanels. Alternatively, you can reset key gains back to their default settings.

Available options for this menu are: *Adjust*, *Minimum*, and *Reset*.

Minimum

The **Minimum** menu item is used to allow an administrator to set a minimum crosspoint volume for individual keys. This prevents users from lowering the crosspoint volume to an inaudible or muted level.

Available options for the minimum volume levels are: *Mute and -80dB to +6dB*.

NOTE: Key Volumes are either enabled for the entire keypanel or disabled for the entire keypanel. This setting cannot be set on a per key basis.

To **enable key volumes**, do the following:

1. Starting at the Audio Options|Key Volumes menu, select **Adjust**.
2. Press the **SEL button**.
Disabled and Enabled appear in the panel display.
3. Using the left or right arrow buttons, select **Enabled**.
4. Press the **SEL button**.
Key volume adjustments are allowed by users.

To **set the minimum volume on every key**, do the following:

1. Starting at the Audio Options|Key Volumes menu, select **Minimum**.
2. Press the **SEL button**.
Adjust Minimum Key Volumes appears in the panel display and the individual keys become active to change the minimum volume.
3. Using the lever associated with the keypanel key, press **left to decrease or right to increase the volume**.

To **reset all key gains to their default value**, do the following:

1. Starting at the Audio Options|Key Volumes menu, select **Reset**.
2. Press the **SEL button**.
Cancel and Do Reset appear in the panel display.
3. Using the left or right arrow buttons, select **Do Reset**.
4. Press the **SEL button**.
Volumes reset appears in the panel display.

Audio Options Menu, Matrix Out

Matrix Out allows the user to select between Normal or Hot Mic. In Normal setting, audio from the selected active mic (based on the mic select feature, see “Audio Options Menu, Panel Mic” on page 199) goes out to the Matrix when any talk key is active. In the Hot Mic setting, audio from the mic goes out to the Matrix without regard to the talk key state.

By default, Matrix Out is set to *Normal* operation.

To **configure Matrix Out**, do the following:

1. Starting at the Audio Options|Matrix Out menu, select **Hot Mic** or **Normal**.
2. Press the **SEL button**.
An arrow appears next to the selected option.

NOTE: When Hot Mic is enabled, the Hot Mic icon appears in the panel display.

Audio Options Menu, Max Volume

The **Max Volume** menu is used to set the maximum level, in dB, of the volume the user can configure for a headset or a speaker. This feature prevents incoming audio from being too loud.

The range for this field is *Mute and -48dB to 10dB*.

The default setting is *10dB*.

To **set the maximum volume for headsets or speakers**, do the following:

1. Starting at the Audio Options|Max Volume menu, select **Headset** or **Speaker**.
2. Press the **SEL button**.
If headset was selected, Left and Right appear in the panel display. If Speaker was selected, Front and Rear appear in the panel display.
3. Using the left or right arrow buttons, select **Left** or **Right**.
4. Press the **SEL button**.
The Max Volume: scroll box appears in the panel display.
5. Using the up and down arrow buttons, scroll to the **maximum volume** you desire.

Audio Options Menu, Mic Gain

Mic Gain allows the user to adjust the mic gain level, in dB, and enable or disable mic gain on the keypad. For more information, see “Key Gain Adjustment” on page 43, “Key Gain Adjustment” on page 43, and “Aux Volume Adjustments” on page 47.

The range for this field is *-20dB to 10dB*.

By default, this field is set to *0dB*.

To **set the Mic Gain level**, do the following:

1. Starting at the Audio Options|Mic Gain menu, select **Level**.
2. Press the **SEL button**.
Front Mic, Left Hdst, Rear Mic, and Right Hdst appear in the panel display.
3. Using the left or right arrow buttons, select the **source to configure mic gain**.
4. Press the **SEL button**.
The Mic Gain scroll box appears in the panel display.
5. Using the up and down arrow buttons, scroll to the **mic gain level** you desire.

To **enable/disable mic gain from the front panel of the keypad**, do the following:

1. Starting at the Audio Options|Mic Gain menu, select **Adjust**.
2. Press the **SEL button**.
Disabled, Front Mic, Left Hdst, Rear Mic, and Right Hdst appear in the panel display.
3. Using the left or right arrow buttons, select the **resource** you want to configure.

Audio Options Menu, Mic Mute

The **Mic Mute** menu is used to configure the actions of the Mic Mute key.

Available options are:

<i>Disabled</i>	By disabling the mic mute key, users are not able to mute the microphone from the front panel.
<i>Momentary</i>	The mic is muted for only as long as the mic mute key is held on.
<i>Toggle</i>	The mic mute key is enabled. In this mode, pressing the mic mute key toggles the mic mute state on and off.

By default, the Mic Mute menu is set to *toggle*.

To **configure the Mic Mute**, do the following:

1. Starting at the Audio Options menu, select **Mic Mute**.
2. Press the **SEL button**.
Disable, Momentary and Toggle appear in the panel display.
3. Using the left or right arrow buttons, select **Disabled, Momentary, or Toggle**.
4. Press the **SEL button**.
An arrow appears next to the selected option.

Audio Options Menu, Min Volume

The **Min Volume** menu item is used to set the minimum volume level, in dB, for different sources on the keypanel. This is the minimum volume level available when using the Main Volume and Aux Volume control knob, located on the front of the keypanel.

Available sources are: *Aux 1, Headset, Speaker, Matrix In, OMNEO 1*, and *OMNEO 2* (OMNEO 3-8 available, if licensed).

The range for this field is *-48dB to 10dB*, and *Mute*.

By default, this field is set to *-6dB* for Matrix In, all other options are set to *Mute*.

To **set the min volume**, do the following,

1. Starting at the Audio Options|Min Volume menu, select the **source** to set the minimum volume on.
2. Press the **SEL button**.
The Min Volume: scroll box appears in the panel display.

NOTE: When Headset or Speaker is selected, you must designate the left or right headset or speaker.

3. Using the up and down arrow buttons, scroll to the **minimum volume** you desire.

Audio Options Menu, Output Level

The **Output Level** menu is used to adjust the nominal audio output level to the matrix.

The range for this field is *0dB to 8dB*.

By default, the output level is set to *8dB*.

To **set the Output Level**, do the following:

- > Starting at the Audio Options|Output Level menu, adjust the **output level**.

Audio Options Menu, Panel Mic

The **Panel Mic** menu option is used to configure how the panel mic operates.

Available options for this field are:

Disabled

Enabled

Switched

When enabled, the state of the Panel Mic is controlled by the Mic Sel key.

NOTE: The default for the Rear Panel Mic is *disabled*, while the default for the Front Panel Mic is *switched*.

To **configure the panel mic**, do the following:

1. Starting at the Audio Options|Panel Mic menu, select **Front** or **Rear**.
2. Press the **SEL button**.
Disabled, Enabled, and Switched appear in the panel display.
3. Using the left or right arrow buttons, select the **mode**.
4. Press the **SEL button**.
An arrow appears next to the selected option.

Audio Options Menu, Preamp Out

The **Preamp Out** menu is used to choose how audio is routed to the Preamp Output connector.

The selections available are:

Disabled

When Disabled is selected, keypanel audio is isolated from the preamp output connector.

Hot Mic

When Hot Mic is selected, audio is always available at the preamp output connector.

Invert

When Inverted is selected, keypanel audio is routed to the preamp output connector when no talk key is active.

Switched (default)

When Switched is selected, keypanel audio is routed to the preamp output connector when a talk key is active.

To **configure the preamp output connector**, do the following:

1. Starting at the Audio Options|Preamp Out menu, select the **preamp out option** you want.
2. Press the **SEL button**.
An arrow appears next to the selected option.

Audio Options Menu, Sidetone

The **Sidetone** menu is used to configure the level, in dB, at which the user hears their own voice. Most people prefer some amount of sidetone to overcome the muffled sensation when talking, especially when wearing a dual-sided headset.

The range for this field is *-65dB to 0dB*.

By default, the sidetone level is set at *-20dB*.

The available options for the sidetone mode are:

Always On

Disabled

Switched (default) When set to Switched, the user's voice is heard only when a talk key is activated.

To **set the sidetone level**, do the following:

1. Starting at the Audio Options|Sidetone menu, select **Level**.
2. Press the **SEL button**.
The Sidetone Level scroll menu appears in the panel display. By default, sidetone is set to -20dB.
3. Using the up and down arrow buttons, adjust the **sidetone level**.

To **set the sidetone mode**, do the following:

1. Starting at the Audio Options|Sidetone menu, select **Mode**.
2. Press the **SEL button**.
Always On, Disabled, and Switched appear in the panel display.
3. Using the left or right arrow buttons, select the **mode** to operate sidetone.
4. Press the **SEL button**.

Audio Options Menu, Speaker

The **Speaker** menu option is used to configure how the speaker operates. Also from this menu the Main Volume shaft encoder is defined how to control the front and rear speakers.

Available selections are:

Always On

Disabled

Switched When set to Switched, the state of the speaker is controlled by the Mic Sel key.

To **configure the speaker**, do the following:

1. Starting at the Audio Options|Speaker menu, select **Front** or **Rear**.
2. Press the **SEL button**.
Always On, Disabled and Switched appear in the panel display.
3. Using the left or right arrow buttons, select the **option** you want configured.
4. Press the **SEL button**.
An arrow appears next to the selected option.

Volume Control

Available selections for the Volume Control menu are:

NOTE: For more information on Ganged Volume configuration, see “Audio Options Menu, Ganged Vols” on page 192.

Ganged The volume controls are tied to each other, only one (1) knob is turned to adjust volume levels. The volume of both front and rear headset speakers are controlled together.

Individual The volume controls are independent of each other.

To **define how the Main shaft encoder controls the volume for the front and rear channels**, do the following:

1. Starting at the Audio Options|Speaker menu, select **Volume Control**.
2. Press the **SEL button**.
Ganged and Individual appear in the panel display.
3. Using the left or right arrow buttons, select either **Ganged** or **Individual**.
4. Press the **SEL button**.
An arrow appears next to the selected option.

Audio Options Menu, Tone Gen

Tone Gen (tone generation) allows the user to turn the tone generator on or off. The tone generator is used to check the audio path from the keypad to the matrix.

Available selections for this menu are:

500Hz Tone (default)

1kHz Tone

To **enable/disable the tone generator**, do the following:

- > Starting at the Audio Options|Tone Gen menu, select **Tone Off** to disable the tone generator.
OR
Using the left or right arrow buttons, select **Tone On** to enable the tone generator.
An arrow appears next to the selected option.

To **set the frequency level for the tone**, do the following:

1. Starting at the Audio Options|Tone Gen menu, select **Frequency**.
2. Press the **SEL button**.
1kHz Tone and 500Hz Tone appears in the panel display.
3. Using the left or right arrow buttons, select **1kHz Tone** or **500Hz Tone**.
An arrow appears next to the selected option. If tone is enabled, an icon indicating 500Hz or 1kHz displays once the menu is exited.

Audio Options Menu, VM Options (Audio Package Only)

The **VM Options** menu is used to configure voice message playback options, voice message recording options, and mailbox full actions.

Playback Menu

The **Playback** menu is used to configure how incoming audio (matrix input, aux input, etc) is handled while the user is listening to a voice message.

Available selections for this menu are:

- | | |
|----------------|---|
| <i>Isolate</i> | All other audio sources are removed from the speaker/headset when playing back a voice message. The user only hears the voice message playing, even if a call is coming in. |
| <i>Mix</i> | The voice message is routed to the speaker/headset along with any other audio sources (matrix input, aux inputs, etc.)
The user hears all audio: voice messages, callers, etc. |

Recording Menu

The **Recording** menu is used to configure when to start and stop recording (Auto Recording). This menu is also used to configure the action taken when the voice message mailbox is full (When Mailbox Full).

Auto Recording

The Auto Recording menu is used to determine when recording begins.

Available options for this menu are:

- | | |
|-----------------------|---|
| <i>Disabled</i> | The panel only records when AFK mode is activated and somebody is leaving a message. |
| <i>Rolling Buffer</i> | The panel continuously records the last 30 seconds of audio, regardless of a voice message being left or not. A caller can still leave a voice message if the panel is AFK and the caller does the Shift+Talk action. (Rolling Buffer and Voice Messages are not mutually exclusive). |

When Mailbox Full

- | | |
|----------------------|--|
| <i>Delete Oldest</i> | When the voice message has reached its limit (7 messages), the oldest voice message is deleted from the queue to make room for an incoming message. |
| <i>Reject New</i> | When a call comes to a keypanel where the voice message has reached its limit (7 messages), the new caller cannot leave a voice message until space becomes available. |

To **configure how incoming audio is handled while listening to voice message**, do the following:

1. Starting at the Audio Options|VM Options menu, select **Playback**.
2. Press the **SEL button**.
Isolate and Mix appear in the panel display.
3. Using the arrow buttons, select **Isolate** or **Mix**.
An arrow appears next to the selected option.

To **configure auto-recording on the keypad**, do the following:

1. Starting at the Audio Options|VM Options menu, select **Recording**.
2. Press the **SEL button**.
Auto-Recording and When Mailbox Full appears in the panel display.
3. Using the arrow buttons, select **Auto-Recording**.
4. Press the **SEL button**.
Disabled and Rolling Buffer appear in the panel display.
5. Using the arrow buttons, select **Rolling Buffer** for the keypad to record the 30 seconds on a loop.
An arrow appears next to the selected option.

To **configure how incoming message requests are handled when the voice message mailbox is full**, do the following:

1. Starting at the Audio Options|VM Options menu, select **Recording**.
2. Press the **SEL button**.
Auto-Recording and When Mailbox Full appears in the panel display.
3. Using the arrow buttons, select **When Mailbox Full**.
4. Press the **SEL button**.
Delete Oldest and Reject New appear in the panel display.
5. Using the arrow buttons, select **Delete Oldest** to remove the oldest voice message to make room for new messages.
OR
Using the arrow buttons, select **Reject New** to reject the voice message request from incoming callers.
An arrow appears next to the selected option.

Menu System, Display

Use this menu to display information about the keypad configuration.

The information available for display is as follows:

Assign Type
Auto Dial
Chans On
Chime
Exclusive
Key Groups
Key List
Level 2 (Key Assignments)
Listen (Assignments)
MAC Address
Matrix
Panel ID
Solo Key
(Keypad Firmware) Version

Display Menu, Assign Type

Assign Type displays the talk level 1 assignment types for all keys.

To **display the types of key assignments assigned to the DKP-4016**, do the following:

1. On the keypad keypad, press **MENU**.
The Information menu appears.
2. Using the left and right arrow buttons, select **Display**.
3. Press the **SEL button**.
The Display submenu appears.
4. Using the left and right arrow buttons, select **Assign Type**.
5. Press the **SEL button**.
The assignment types appear on the appropriate key displays.

Display Menu, Auto Dial

Auto Dial displays the keypad keys assigned 1-touch auto dial numbers. 1-Touch auto dial numbers are configured using the locally stored numbers on the keypad. Once a 1-touch auto dial key is configured, press the configured key to cause the TIF to go off-hook and auto dial the selected number.

To **display the auto dial numbers assigned to the keypad keys**, do the following:

1. Starting at the Display menu, select **Auto Dial**.
2. Press the **SEL button**.
1-Touch Auto Dial appears in the panel display and the keys with 1-Touch Auto Dial numbers assigned are indicated with a red bar talk bar.

Display Menu, Chans On

Chans On displays a scroll list of all intercom ports with crosspoints currently closed to this keypanel. Chans On is typically used to locate an open mic or other open audio source that needs to be shut off. The most likely cause is a talk key that has been left on at some keypanel. In this case, use the arrow buttons to quickly page-scroll through the list of names. Press the call waiting window key to ask the person at the other end of the connection to turn off the talk key.

To **display the Chans On information**, do the following:

1. Starting at the Display menu, select **Chans On**.
2. Press the **SEL button**.
The Chans On display appears showing the active channels.

Display Menu, Chime

Chime displays all keys with the chime option enabled on them in red. For more information, see “Key Options Menu, Chime” on page 214.

To **display keys with Chime enabled**, do the following:

1. Starting at the Display menu, select **Chime**.
2. Press the **SEL button**.
The Chime display appears showing chime enabled keys in red.

Display Menu, Exclusive

Exclusive displays all keys with the exclusive key assignment. For more information, see “Key Options Menu, Exclusive” on page 215.

To **display the Exclusive Keys information**, do the following:

1. Starting at the Display menu, select **Exclusive**.
2. Press the **SEL button**.
The Exclusive display appears showing exclusive keys in red.

NOTE: You can assign more than one (1) Exclusive key. Only one (1) key marked as an Exclusive key can be turned on at any time. Pressing an Exclusive key turns off any other Exclusive key already active.

Display Menu, Key Groups

Key Groups displays a scroll list of groups available on the keypanel.

To **display the different groups available**, do the following:

1. Starting at the Display menu, select **Key Groups**.
2. Press the **SEL button**.
Group 1, Group 2, Group 3, and Group 4 appear in the panel display.
3. Using the arrow buttons, select the **Group** you want to display.
4. Press the **SEL button**.
The Master key appears in red, while the slave keys appear in green.

Display Menu, Key List

Key List displays and allows users to see all the other assignments on other keypad pages not currently showing in the keypad display.

To **display the Key List information**, do the following:

1. Starting at the Display menu, select **Key List**.
2. Press the **SEL button**.
The Key List displays all the assignments not currently displayed on the keypad.

Display Menu, Level 2

Level 2 displays the talk level 2 assignments for any key that has them assigned. Talk level 2 assignments are used to call two (2) users at one (1) time, activated when the Level 1 assignment is used.

To **display the Level 2 Talk information**, do the following:

1. Starting at the Display menu, select **Level 2**.
2. Press the **SEL button**.
The Level 2 display appears showing the level 2 talk assignments.

Display Menu, Listen

Listen displays the listen assignments for all keys, if applicable.

To **display the Level 2 Talk information**, do the following:

1. Starting at the Display menu, select **Listen**.
2. Press the **SEL button**.
The Listen display appears showing the listen assignments for all keys (if assigned).

Display Menu, MAC Address

MAC Address displays the MAC Address of the keypad.

To **display the MAC Address**, do the following:

1. Starting at the Display menu, select **MAC Address**.
2. Press the **SEL button**.
The MAC Address for the keypad appears.

Display Menu, Matrix

Matrix displays the intercom system name for all talk level 1 key assignments. The local intercom is represented by a green key, while a remote intercom is represented by a red key. If a key assignment is not present on a key, an unassigned key displays.

In non-trunked intercom systems, the intercom system name is always LOCL (local). In trunked systems, intercom system names are created in TrunkEdit (*Intercoms|Names*).

To **display the matrix intercom system name**, do the following:

1. Starting at the Display menu, select **Matrix**.
2. Press the **SEL button**.
The Matrix display appears showing the matrix intercom system.

Display Menu, Panel ID

Panel ID displays the port number to which the keypanel is connected.

NOTE: When the keypanel is not scroll enabled, the Panel ID displays only the port number in the panel display. When the keypanel is scroll enabled, the port number and port alpha are displayed.

To **display the panel ID**, do the following:

1. Starting at the Display menu, select **Panel ID**.
2. Press the **SEL button**.
The Panel ID display appears showing the port number and alpha (if applicable) for the keypanel.

Display Menu, Solo

Solo displays the key with the solo assignment. For more information, see “Key Options Menu, Latching” on page 217.

To **display the Solo Key information**, do the following:

1. Starting at the Display menu, select **Solo**.
2. Press the **SEL button**.
The Solo display appears showing solo keys in red.

NOTE: You may only assign one (1) solo key at a time.

Display Menu, Version

Version displays the firmware version currently running on the keypanel.

NOTE: For firmware upgrades, contact customer service. The keypanel firmware can be upgraded through AZedit.

To **display the firmware version currently loaded on the keypanel**, do the following:

1. Starting at the Display menu, select **Version**.
2. Press the **SEL button**.
The Version display appears showing firmware version for the keypanel.

Menu System, Key Assign Menu

The **Key Assign** menu is used to assign intercom key assignments and auto functions to keypanel keys.

Available options for this menu are:

Matrix (only in trunked systems)

Pt-to-Pt

Party Line

IFB

Special List

Sys Relay

Camera ISO

UPL

IFSL

Auto Func

To **access the key assign menu options**, do the following:

1. Starting at the Key Assign menu, select the **key assignment type** you want to assign.
2. Press the **SEL button**.
A scroll list of available assignments appears.

Key Assign Menu, Matrix (Trunked System Only)

Matrix only appears for trunked intercom systems. You must select a remote intercom matrix before assigning intercom keys to destinations in that matrix. You do not need to select matrix to assign keys to destinations in your own matrix. Also, you do not need to select matrix when assigning an auto function key to a matrix.

To **assign a remote assignment to the DKP-4016/4016W**, do the following:

1. Starting at the KeyAssign|Matrix menu, select a **remote intercom**.
2. Press the **SEL button**.
A scroll list of available assignments appears.
3. Using the arrow buttons, select the **assignment** you want to assign to the keypanel key.
4. Press the **SEL button**.
A list of auto-functions appear.
5. Using the arrow buttons, select the **auto-function** you want to assign to the assignment, if applicable.
6. Press the **SEL button**.
Tap Key appears in the panel display.
7. Press down on the **keypanel key position** where you want the assignment to appear.
The alpha name appears on the key.

Key Assign Menu, Pt-to-Pt

Pt-to-Pt assigns a key that talks or listens to another intercom port.

NOTE: Some Pt-to-Pt destinations may be non-keypanel devices that cannot activate talk and listen paths. Therefore, if you want full communication, you may need to assign both talk and listen on the key. For more information, see “Key Assign Menu, Auto Func” on page 212.

To **assign Pt-to-Pt to the keypanel key**, do the following:

1. Starting at the Key Assign|Pt-to-Pt menu, select the **port** you want to assign to the keypanel key.
2. Press the **SEL button**.
A list of auto-functions appear.
3. Using the arrow buttons, select the **auto-function** you want to assign to the Pt-to-Pt assignment, if applicable.
4. Press the **SEL button**.
Tap Key appears in the panel display.
5. Press down on the **keypanel key position** where you want the Pt-to-Pt assignment to appear.
The key color changes and the alpha appears on the key.

Key Assign Menu, Party Line

Party Line assigns a key that talks and/or listens to a party line. Party Lines are defined in AZedit.

NOTE: Party Line members are usually non-keypanel devices that cannot activate talk and listen paths. Therefore, if you want full communication, you need to assign both talk and listen on the key. If all communications are normally 2-way, you may wish to assign the key as Talk+Auto Listen.

To **assign a Party Line to the keypanel key**, do the following:

1. Starting at the KeyAssign|Party Line menu, select the **party line** you want to assign to the keypanel key.
2. Press the **SEL button**.
A list of auto-functions appear.
3. Using the arrow buttons, select the **auto-function** you want to assign to the Party Line assignment, if applicable.
4. Press the **SEL button**.
Tap Key appears in the panel display.
5. Press down on the **keypanel key position** where you want the Party Line assignment to appear.
The key color changes and the alpha appears on the key.

Key Assign Menu, IFB

IFB assigns the IFB assignment type to a key. By default, all IFBs are restricted. You must select the appropriate scroll enable check box in AZedit, to see IFBs.

To **assign an IFB to the keypanel key**, do the following:

1. Starting at the KeyAssign|IFB menu, select the **IFB assignment** you want to assign to the keypanel key.
2. Press the **SEL button**.
A list of auto-functions appear.
3. Using the arrow buttons, select the **auto-function** you want to assign to the IFB assignment, if applicable.
4. Press the **SEL button**.
Tap Key appears in the panel display.
5. Press down on the **keypanel key position** where you want the IFB assignment to appear.
The key color changes and the alpha appears on the key.

Key Assign Menu, Spcl List

Spcl List assigns a key that talks and/or listens to a special list. The key is not available until members have been assigned to the special list in AZedit.

NOTE: Special List members can be non-keypanel devices that cannot activate talk and listen paths. Therefore, if you want full communication with all members of the special list, you may need to assign both talk and listen on the key.

To **assign a Special List to the keypanel key**, do the following:

1. Starting at the KeyAssign|Special List menu, select the **Special List** you want to assign to the keypanel key.
2. Press the **SEL button**.
A list of auto-functions appear.
3. Using the arrow buttons, select the **auto-function** you want to assign to the Special List assignment, if applicable.
4. Press the **SEL button**.
Tap Key appears in the panel display.
5. Press **down** on the keypanel key position where you want the Special List assignment to appear.
The key color changes and the alpha appears on the key.

Key Assign Menu, Sys Relay

Sys Relay refers to any of several types of control devices that can exist in the intercom system, including:

- The 8 GPI outputs from an ADAM Frame (J11 on the XCP-ADAM-MC Breakout Panel).
- The GPI outputs from an Cronus (J9 on the back of Cronus).
- The GPI outputs of an Zeus III Frame (located on the rear panel).
- The 16 GPI outputs of a UIO-256 or GPIO-16 Frame (J5 on the UIO-256/GPIO-16 back panel).

To **assign a Relay to the keypanel key**, do the following:

1. Starting at the KeyAssign|Sys Relay menu, select the **Relay** you want to assign to the keypanel key.
2. Press the **SEL button**.
A list of auto-functions appear.

NOTE: You will not hear anything if you listen to a Relay, but you can activate the relay with either a talk or listen key.

3. Using the arrow buttons, select the **auto-function** you want to assign to the relay assignment, if applicable.
4. Press the **SEL button**.
Tap Key appears in the panel display.
5. Press down on the **keypanel key position** where you want the Relay assignment to appear.
The key color changes and the alpha appears on the key.

Key Assign Menu, Camera ISO

Camera ISO assigns an **ISO** (isolate) assignment type to the key. By default, all ISOs are restricted. You must select the appropriate scroll enable check box in AZedit, to see ISOs.

To **assign a Camera ISO to the keypad key**, do the following:

1. Starting at the KeyAssign|Camera ISO menu, select the **ISO** you want to assign to the keypad key.
2. Press the **SEL button**.
A list of auto-functions appear.
3. Using the arrow buttons, select the **auto-function** you want to assign to the Camera ISO assignment, if applicable.
4. Press the **SEL button**.
Tap Key appears in the panel display.
5. Press down on the **keypanel key position** where you want the Camera ISO assignment to appear.
The key color changes and the alpha appears on the key.

Key Assign Menu, UPL Resources

UPL Resources assigns a key the UPL resource assignment type to the key. By default, all UPL resources are restricted. You must select the appropriate scroll enable check box in AZedit, to see UPLs.

To **assign a UPL to the keypad key**, do the following:

1. Starting at the KeyAssign|UPL menu, select the **UPL** you want to assign to the keypad key.
2. Press the **SEL button**.
A list of auto-functions appear.

NOTE: You will not hear anything if you listen to a UPL Resource, but you can activate the UPL with either a talk or listen key.

3. Using the arrow buttons, select the **auto-function** you want to assign to the UPL assignment, if applicable.
4. Press the **SEL button**.
Tap Key appears in the panel display.
5. Press down on the **keypanel key position** where you want the UPL assignment to appear.
The key color changes and the alpha appears on the key.

Key Assign Menu, IFB SL

IFB SL (IFB Special List) is similar to a special list, except the members of these special lists are IFB assignments. IFB SLs are useful when a producer of a news program needs to talk to all the talent at the same time (most talent assignments are IFB assignments).

To **assign an IFSL to the keypad key**, do the following:

1. Starting at the KeyAssign|IFSL menu, select the **IFSL** you want to assign to the keypad key.
2. Press the **SEL button**.
A list of auto-functions appear.
3. Using the arrow buttons, select the **auto-function** you want to assign to the IFSL assignment, if applicable.
4. Press the **SEL button**.
Tap Key appears in the panel display.
5. Press down on the **keypanel key position** where you want the IFSL assignment to appear.
The key color changes and the alpha appears on the key.

Key Assign Menu, Auto Func

Auto Func assigns an auto function to the key.

Available options for this menu are:

<i>AF</i>	Auto Follow for listen keys only.	Listens to what is assigned on the Talk key.
<i>AL</i>	Auto Listen for listen keys only.	When Talk is pressed, the Listen turns on.
<i>AM</i>	Auto Mute for listen keys only.	If Listen is active and Talk is pressed, Listen turns off.
<i>AR</i>	Auto Recip for listen keys only.	Listen is always on.
<i>AC</i>	All Call for talk level 1 only.	Turns all Talk keys on to the left of the AC key, up to the next AC key or the end of the row.
<i>Dim</i>	Dim Table function, for talk level 2 on point-to-point keys only.	

To **assign an Auto Function**, do the following:

1. Starting at the KeyAssign|Auto Funcs menu, select the **auto function** you want to assign to the keypad key.
2. Press the **SEL button**.
Tap Key appears in the panel display.
3. Press the **keypanel key** to which you want to assign the auto function.

Menu System, Key Options Menu

The **Key Options Menu** is used to configure many of the keypad operation options, such as auto dial functions, chime keys and duration, exclusive keys, key group assignments, solo key configuration, latching options, button lock, and tally operation.

Available options for this menu are:

Auto Dial
Chime
Clear
Exclusive
Icons
Key Groups
Latching
Lock
Panel Swap
Solo
Tallies
Turn Off

Key Options Menu, Auto Dial

Auto Dial stores commonly used phone numbers in the auto dial list locally on the keypad.

You can also create a centralized auto dial list which is stored on the Master Controller and maintained through AZedit. For more information, see “Centralized Auto Dials” on page 247.

You can configure *up to 100 locally stored auto dial numbers*.

You can also configure 1-Touch TIF Auto Dial. 1-Touch Auto Dials are configured using the locally stored numbers on the keypad. Once a 1-Touch Auto Dial key is configured, pressing the configured key causes the TIF to go off-hook and auto dial the selected number.

To **store an auto dial number**, do the following:

1. Starting at the Key Options|Auto Dial menu, select **Numbers**.
2. Press the **SEL button**.
#01:<empty> appears in the panel display.
3. Use the arrow buttons, to scroll to the **auto dial entry** you want to use.

NOTE: There are up to 100 auto dial entries available.

4. Press the **SEL button**.
#01: with a blinking cursor appears in the panel display.
5. Using the keypad keypad, enter the **phone number** you want to store (for example, 5551234567).

IMPORTANT: You can use either FWD/BACK or Aux Shaft Encoder push (FWD)/MAIN Shaft Encoder push (BACK) on the DKP-4016.

6. On the keypad keypad, press **FWD**.
Save Number? appears in the panel display.
7. Press the **SEL button**.
The auto dial position number and telephone number appear in the panel display.

To **delete a stored auto dial number**, do the following:

1. Starting at the Key Options|Auto Dial menu, select **Numbers**.
2. Press the **SEL button**.
#01:<empty> appears in the panel display.
3. Using the arrow buttons, select the **Auto Dial number** you want to remove.
4. Press the **SEL button**.
#01: with a flashing cursor appears.

NOTE: #01 is used for example purposes only. Depending on the auto dial number you want to delete determines the number seen here.

5. Press **FWD**.
Save Number? appears.
6. Press the **SEL button**.
#01: <empty> appears in the panel display. The auto dial number is erased.

To **configure a 1-touch auto dial key**, do the following:

1. Starting at the Key Options|Auto Dial menu, select **1-Touch**.
2. Press the **SEL button**.
Tap Key appears in the panel display.
3. Tap the **key** you want to put the TIF 1-Touch assignment.
A scroll list of auto dial phone numbers appear.
4. Using the arrow buttons, select the **phone number** you want to assign to the key.

NOTE: To hang up after using the 1-Touch key, you must use the TIF menu or assign Drop to a UPG key. For more information, see “User Programmable Buttons” on page 64.

Key Options Menu, Chime

Chime indicates a chime tone sounds on incoming call announcements for selected keypanel keys. You can configure the chime tone to activate for a specified amount of time after a call is received.

The range for this field is one (1) second to five (5) minutes.

NOTE: Keys that have the currently selected Chime and Duration are shown with a red talk bar. Keys with a different chime or duration are shown with a green talk bar. Keys with no chime do not show a talk bar.

To **add a chime tone to keypanel keys**, do the following:

1. Starting at the Key Options, select **Chime**.
2. Press the **SEL button**.
A Chime scroll box and a Duration scroll box appear in the panel display.
3. Using the up and down arrow buttons, select the **system chime** you desire (for example, System #1 through System #12. Additionally, if licensed, User #1 through User #4).
4. Press the **SEL button**.
The focus moves to the duration scroll box.
5. Using the up and down arrow buttons, select the **duration of the chime**.
6. Tap **down** on each keypanel key to which you want to add Chime.

NOTE: Assigning <none> clears the chime from the key. When you change chime types, if Preview is enabled, you hear the chime play. Also, if you lift the listen key for any key showing it has a chime assigned, you hear the chime associated with that key.

Key Options Menu, Clear

The **Clear** menu option is used to clear any key options that have been assigned to a specific key or to clear the UPG button assignment.

To **clear a key's key options**, do the following:

1. Starting at the Key Options menu, select **Clear**.
2. Press the **SEL button**.
Tap Key appears in the panel display.
3. Tap the **key** you want to clear the key options from.
The key options are removed from the keypanel key.

To **clear a UPG key options**, do the following:

1. Starting at the Key Options menu, select **Clear**.
2. Press the **SEL button**.
Tap Key appears in the panel display.
3. Press or tap the **UPG key** you want to clear the UPG programming from.
The key options are removed from the UPG key.

Key Options Menu, Exclusive

Exclusive allows the user to set up keys that cause any other exclusive keys to turn off when activated. Unlike the solo option, when the exclusive option is deactivated, the other exclusive key turns off and does not turn back on. You can assign multiple exclusive keys.

To **create an exclusive key assignment**, do the following:

1. Starting at the Key Options menu, select **Exclusive**.
2. Press the **SEL button**.
Tap Key appears in the panel display.
3. Tap **down** on any keypad key you want to assign the exclusive key option.
The key display turns red.

To **remove an exclusive key assignment**, do the following:







1. Starting at the Key Options menu, select **Exclusive**.
2. Press the **SEL button**.
Tap Key appears in the panel display.
3. Tap **down** on each red keypad key from which you want to remove the exclusive key option.
The selected keys return to the unassigned state (light blue color).

Key Options Menu, Icons

The **Icons** menu option is used to enable icon overlays for various key states. There are seven (7) key states that can be indicated using an icon.

By default, icons are enabled, which means they are displayed.

The icons available are:

	Gold Star	Key is Solo Key
	Black Phone	Key has TIF Assignment
	Globe	Key has Remote/Trunk assignment
	Bell	Key has Chime
	Plus	Key is Group Master
	Number Sign	Key has Auto-Dial
	Minus	Key is Exclusive

To **enable/disable icon overlays**, do the following:

1. Starting at the Key Options menu, select **Icons**.
2. Press the **SEL button**.
An Icon scroll box and a Display scroll box appear in the panel display.
3. Using the up and down arrows, select the **key state** you want from the Icon scroll box.
4. Using the left and right arrows, select **Display**.
5. Using the up and down arrows, select **Enable** to display the icon.
OR
Using the up and down arrows, select **Disable** to hide the icon.
6. Repeat **steps 3 through 5** until you are finished.

Key Options Menu, Key Groups

Key Groups is used to create a key group. A key group allows the user to activate a group of keys by activating one (1) key (the master key). When the master key is activated, all keys in the group become active.

You can create *up to four (4) key groups*.

To **create a key group**, do the following:

1. Starting at the Key Options|Key Groups menu, select the **Group** (1–4) you want to create.
2. Press the **SEL button**.
Tap Master Key appears in the panel display.
3. Tap **down on the keypad key** you want to act as the master key.
OR
Press **FWD** to skip creating a Master key
The selected key displays a red talk bar and Tap Slave Key(s) appears in the panel display.

NOTE: A group without a master key cannot be activated by a key press, but may still be activated by a GPI Input or UPG key.

4. Tap **down on the keypad keys** you want to be activated when the master key is selected.
The selected keys display a green talk or listen bar.

To **delete a key group**, do the following:

1. Starting at the Key Options|Key Groups menu, select the **Group** (1-4) you want to delete.
2. Press the **SEL button**.
Tap the Master Key appears in the panel display.
3. Press the **FWD** key.
The selected key returns to the unassigned state (light blue color) and Tap Slave Key(s) appears in the panel display.
4. Tap **down on the green keypad keys** you want to remove from the group.
The selected keys lose their green talk or listen bar.

Key Options Menu, Latching

Latching is used to enable or disable the keypad key to stay on when pressed. When Latching is enabled, the talk function stays on after the talk key is pressed briefly. Otherwise, the talk function only works when the button is pressed. You configure globally across all keys, or on a per key basis.

NOTE: A key only latches if it is pressed and released within 0.5 seconds. Otherwise, the key always turns off when released.

By default, latching is *enabled*.

To **set latching on a keypad key**, do the following:

1. Starting at the Key Options menu, select **Latching**.
2. Press the **SEL button**.
Global and Per Key appear in the panel display.
3. Using the left and right arrow buttons, select either **Global** or **Per Key**.
4. Press the **SEL button**.
Disabled and Enabled appear in the panel display.
5. Using the arrow buttons, select **Enabled** or **Disabled**.
An arrow appears next to the selected option.

Key Options Menu, Lock (Button Lock)

Lock is used to lock keypad keys in the on or off position. Each key may be independently locked on or off.

To **lock a button on**, do the following:

1. Starting at the Key Options| menu, select **Lock**.
2. Press the **SEL button**.
Tap Key appears in the panel display.
3. Tap a **key** once to lock it on.
A green indicator appears. This indicates the key is locked on.
OR
Tap the **key again** to lock it off.
A red indicator appears indicating the key is locked off, meaning the user cannot turn the key on or off.
OR
Tap the **key again** to release the lock.

Key Options Menu, Panel Swap

Panel Swap gives users the ability to quickly and easily change a group of keypad assignments on the keypad. This is done through the use of virtual expansion panels. Panel swap differs from changing setup pages because the keys can stay active even when they are no longer visible on the main panel. Also, panel swap allows the user a 1-touch trigger to complete two (2) actions at once.

Even though the DKP-4016 does not support physical EKPs, Panel Swap and Virtual EKPs are still available for use.

IMPORTANT: The number of actual physical keys on the keypad must be less than the numbers of keys per port supported by the intercom.

For example, the DKP-4016 has 16 physical keys and if the matrix supports 64 keys per port; then three virtual EKPs can be used (since each EKP adds 16 virtual keys to the keypad).

Panel swap can be activated by (or triggered by) a UPG key, a GPI Input, or GPI Output allowing local or remote access. A GPI board does not need to be installed to be controlled by GPI Outputs. However you must set up a Setup Page in AZedit for the virtual EKP to be able to assign key assignments.

Panel Swap Control Options

There are five (5) ways to activate panel swap:

Keypad FWD

Keypad BACK



Keypad UPG1 to UPG 9

GPI Inputs Opto 1 and Opto 2

GPI Outputs Relay 1 and 2

Navigation Mode for Panel Swap

Once you have selected the control trigger, select what panel swap action is performed:

<i>Cycle To</i>	Cycle to the Next or Previous panel.
<i>Switch To</i>	Switch to a specific panel (for example, MAIN, EKP1, EKP2, etc. The following icon appears briefly when the Main page is showing  The following icon appears when the first virtual EKP is showing  . Subsequent virtual EKPs display their number in the icon.
<i>Toggle To</i>	Toggle between MAIN and a specific virtual EKP.
<i>Unassigned</i>	Used to erase the panel swap action from a trigger or control mechanism.

Panel Swap Key States

Key States define what happens to the key states when a row of keys is not currently visible. There are two (2) possible modes of operation:

<i>Force Off</i>	Talk and listen key states are forced off when the row of keys is not visible.
<i>Retain</i>	Talk and listen key states are retained when the row of keys is not visible. When retain is selected and active talk or listen keys are not visible, the following icon shows in the panel display. 

In the menu structure, under Panel Swap, the menu items Control and Key States appear, but are unavailable on the keypad until one (1) or more virtual EKPs are enabled.

To **enable virtual keypanels**, do the following:

1. Starting at the Key Options|Panel Swap menu, select **Virtual EKPs**.
2. Press the **SEL button**.
None, 1 EKP, 2 EKPs, etc appear in the panel display.

IMPORTANT: The number of virtual EKPs that appear in the selections depends on the number of keys per port the intercom is configured for.

3. Using the arrow buttons, select the **maximum number of virtual EKPs to enable**.
4. Press the **SEL button**.
An arrow appears next to the selected option.

To **configure how to access the virtual EKPs from the front of the keypad**, do the following:

1. Starting at the Key Options|Panel Swap menu, select **Control**.
2. Press the **SEL button**.
GPI Inputs, GPI Outputs, and Keypad appear in the panel display.
3. Using the arrow buttons, select the **control mechanism** desired.
4. Press the **SEL button**.
The appropriate sub-control mechanism appears (see "Panel Swap Control Options" on page 218).
5. Using the arrow buttons, select the **sub-control mechanism**.
6. Press the **SEL button**.
Cycle To, Switch To, Toggle To, and Unassigned appear in the panel display.
7. Using the arrow buttons, select the **navigation mode** desired.

8. Press the **SEL button**.
A list of actions for the keypad action appears in the panel display (see “Panel Swap Key States” on page 219).
9. Using the arrow buttons, select the **action** desired.
10. Press the **SEL button**.
An arrow appears next to the selected option.

To **configure the panel swap key states**, do the following:

1. Starting at the Key Options|Panel Swap menu, select **Key States**.
2. Press the **SEL button**.
Force Off and Retain appear in the panel display.
3. Using the arrow buttons, select the **key state** you want to enable (see “Panel Swap Key States” on page 219).
4. Press the **SEL button**.
An arrow appears next to the selected option.

To **erase any programming from the panel swap configuration**, do the following:

1. Starting at the Key Options|Panel Swap menu, select **Control**.
2. Press the **SEL button**.
GPI Inputs, GPI Outputs, and Keypad appear in the panel display.
3. Using the arrow buttons, select the **control mechanism you want to erase**.
4. Press the **SEL button**.
The appropriate sub-control mechanism appears (see “Panel Swap Control Options” on page 218).
5. Using the arrow buttons, select the **sub-control mechanism you want to erase**.
6. Press the **SEL button**.
Cycle To, Switch To, Toggle To, and Unassigned appear in the panel display.
7. Using the arrow buttons, select **Unassigned**.
8. Press the **SEL button**.
An arrow appears next to the selected option.

Key Options Menu, Solo

Solo allows the user to set up a key that causes all other keys to turn off when activated. However, when the solo key is released, the keys that were turned off by the solo key turn back on.

You can assign only one (1) solo key.

To **create a solo key**, do the following:

1. Starting at the Key Options menu, select **Solo**.
2. Press the **SEL button**.
Tap Key appears in the panel display.
3. Tap **down on the keypad key** you want to configure as solo.
The selected talk key indicator turns red.

To **remove a solo key**, do the following:

1. Starting at the Key Options menu, select **Solo**.
2. Press the **SEL button**.
Tap Key appears in the panel display.
3. Tap **down on the red solo keypad key** you want to remove the solo assignment.
The selected talk key indicator turns red.

Key Options Menu, Tallies

Tallies are used to indicate incoming calls with blinking alpha assignments. You can configure tally time as 5, 10, or 15 seconds or set it as indefinite.

If indefinite is selected, when a caller presses and releases the talk key, a tally with a minimum duration appears. If the call is answered before the minimum duration is met, the tally is cancelled. However, if indefinite is selected and a caller presses and holds (or latches) the talk key, the tally continues until the caller releases the key. This means the tally continues through the call if the caller does not release the key.

NOTE: When DKP-4016/4016W keypanels are connected to legacy intercoms (for example, intercoms that do not support Enhanced Tallies, the available options for this menu are relevant.

When DKP-4016/4016W keypanels are connected to intercoms that support Enhanced Tallies, the Enhanced Tallies view allows you to globally configure how the tally behaves. (the options in the Tally menu in the keypanel are not relevant). For more information, see “Enhanced Tallies” on page 74.

By default, tallies are set to *15 seconds*.

To **set the tally time on an incoming call**, do the following:

1. Starting at the Key Options|Tallies menu, select **Min Duration**.
2. Press the **SEL button**.
A Min Duration scroll box appears in the panel display.
3. Using the up and down arrow buttons, select the **duration** you desire.

To **set the tally time to indefinite on an incoming call**, do the following:

1. Starting at the Key Options|Tallies menu, select **Indefinite**.
2. Press the **SEL button**.
Disabled and Enabled appear in the panel display.
3. Using the up and down arrow buttons, select **Disable** or **Enable**.

Key Options Menu, Turn Off

The **Turn Off** menu item allows the user to quickly turn off all keys, all talk keys, or all listen keys. This menu item can be used with the programmable UPG keys to create a UPG key which can turn off all keys with one (1) push of a key.

To **turn off keys on the keypanel using the menu**, do the following:

1. Starting at the Key Options|Turn Off menu, select **All Keys**, **Talk Keys**, or **Listen Keys**.
2. Press the **SEL button**.
Turn Keys Off? appears in the keypanel panel display.
3. Press the **SEL button**.
Keys Turned Off appears in the keypanel panel display.

To **configure a UPG to turn off keys**, do the following:

1. Starting at the Key Options|Turn Off menu, select **All Keys**, **Talk Keys** or **Listen Keys**.
2. Press the **SEL button**.
Turn Keys Off? appears in the keypanel panel display.
3. Press the **SEL button**.
Keys Turned Off appears in the keypanel panel display.
4. On the keypanel, press and hold a **UPG key** until the message Menu position saved appears in the keypanel panel display.
Keys Turned Off appears in the keypanel panel display once the UPG key is released.

To **configure a UPG to require a confirmation before turning off keys**, do the following:

1. Starting at the Key Options|Turn Off menu, select **All Keys**, **Talk Keys** or **Listen Keys**.
2. Press the **SEL button**.
Turn Keys Off? appears in the keypanel panel display.
3. On the keypanel, press and hold a **UPG key** until the message Menu position saved appears in the keypanel panel display.
Turn Keys Off? reappears in the keypanel panel display.
4. Press the **SEL button**.
Keys Turned Off appears in the keypanel panel display.

Menu System, OMNEO Offers

The **OMNEO Offers** menu item is used to configure the keypanel to communicate with the matrix via an OMNEO or AIO connection. From this menu, you can also configure the OMNEO channels to be used for AUX Inputs.

OMNEO Matrix Connection Configuration

To **configure an available OMNEO device connection port**, do the following:

1. Starting at the OMNEO Offers|Keypanel menu, select **OKP**.
2. Press the **SEL button**.
A list of available OMNEO offers appear.
3. Using the arrow buttons, select the **OMNEO offer** you want to use.
An arrow appears next to the device.

OMNEO Aux Port Configuration

To **configure the OMNEO channels as Aux Inputs**, do the following:

1. Starting at the OMNEO Offers|Keypanel menu, select **Aux Input**.
2. Press the **SEL button**.
OMNEO 1 and OMNEO 2 appears in the panel display.
3. Using the arrow buttons, select **OMNEO 1** or **OMNEO 2** (OMNEO 3-8 available, if licensed).
4. Press the **SEL button**.
A list of available OMNEO offers appears.
5. Using the arrow buttons, select the **OMNEO offer** you want to configure as an Aux Input.
6. Press the **SEL button**.
The OMNEO Aux Input is configured.

Menu System, RVON Offers (Only available when an RVON-IO is detected)

The **RVON Offers** menu item is used to configure the matrix connection when an RVON-I/O is attached to the AIO port on the back of the keypanel.

RVON-IO Matrix Connection

RVON-I/O RVON-16, RVON-8, RVON-C, and RVON-I/O (in local mode). Use the Frame connection on the back panel of the keypanel.

NOTE: For more information about RVON-I/O configuration, see the RVON-I/O user manual (F.01U.193.280).

To **configure the Matrix connection port**, do the following:

1. Starting at the RVON Offers|Keypanel menu, select the **Matrix connection type** you want to use.

NOTE: If an RVON-I/O is connected to the keypanel, RVON-I/O replaces the AIO menu option.

2. Using the arrow buttons, select the **port** you want to use.
An arrow appears next to the port.

Menu System, Save Config

The **Save Config** menu option is used to save custom settings made in the Audio Options, Key Options or Service menus. Once you have made modifications via these menus, run Save Cfg to store the custom settings in non-volatile memory. This ensures your custom settings are saved when the keypanel is powered down. You can run Reset Config (see “Service Menu, Reset Cfg” on page 239), to erase all custom settings.

To **run a save config**, do the following:

1. On the keypad, press **MENU**.
The main menu appears.
2. Using the arrow buttons, select **Save Config**.
3. Press the **SEL button**.
Configuration Saved appears in the panel display.

Menu System, Service

The information available for key assign is as follows:

Alphas
Aux Select
CWW
Display
Footswitch
Intercom Mode
Key View
Keypad
LCD Backlight
Local GPIO
Mirror
OMNEO Setup
Page Change
Reset Cfg
RVON Setup
Scrn Saver
Set Address
Snoop Tally
Test Panel

Service Menu, Alphas

The **Alphas** menu is used to select the alpha size (length) and type to be displayed for key assignments.

NOTE: When a Reset Cfg is performed, the Alpha Size and Poll ID do not get reset.

Available options are:

4 Chars
6 Chars
8 Chars
8 Chars (Unicode)

IMPORTANT: Keypanel on the same AIO-8, or on the same group of eight (8) on an AIO-16, Zeus I/II (but not III), or ADAM CS must have the same alpha size selected. But each group of eight (8) can support a different alpha size.

To **set the alpha size**, do the following:

1. Starting at the Service|Alphas menu, select **4 Chars**, **6 Chars**, **8 Char**, or **8 Chars (Unicode)**.
2. Press the **SEL button**.
Cancel and Save and Restart appear in the panel display.
3. Using the arrow buttons, select **Save and Restart**.
4. Press the **SEL button**.
The keypad restarts itself with the new alpha size.

Service Menu, Aux Select

The **Aux Select** menu is used to select the number of analog auxiliary inputs on the keypad when the panel has been licensed for OMNEO 3-8.

When a keypad is not licensed, meaning it only has OMNEO 1 and 2, then the number of analog aux inputs is the maximum supported by the panel:

- KP-5032/4016 - Maximum number of Analog Aux = 2, OMNEO 1-2, plus Aux 1-2
- DKP-4016 - Maximum number of Analog Aux = 1, OMNEO 1-2, plus Aux 1
- KP-3016- Maximum number of Analog Aux = 0, OMNEO 1-2
- KP-3016A does not support OMNEO

When the keypad is licensed for OMNEO 3–8, OMNEO 8 and Aux 1 are multiplexed, meaning you can have one or the other, but not both. The same rule applies to OMNEO 7 and Aux 2; both are multiplexed and both cannot be used together. Also, you cannot have Aux 2 without Aux 1.

The options available if OMNEO 3–8 are licensed:

- Number of Analog Aux = 2, OMNEO 1-6, plus Aux 1-2
- Number of Analog Aux = 1, OMNEO 1-7, plus Aux 1
- Number of Analog Aux = 0, OMNEO 1-8

Service Menu, CWW

The **CWW** menu is used to configure the CWW (Call Waiting Window). There are two configuration options; how many calls can be shown in the CWW and what happens to the highlight when a new call comes in to the keypad.

Number of Entries

The **Number of Entries** sub-menu is used to define how many calls can be shown in the CWW. The maximum number of entries is 9, while the minimum is 3 (2 in Unicode).

To **select the number of entries allowed for the CWW**, do the following:

1. Starting at the Service menu, select **CWW**.
2. Press the **SEL button**.
Number of Entries and On New Caller appears in the panel display.
3. Using the arrow buttons, select **Number of Entries**.
4. Press the **SEL button**.
The Number of CWW Entries scroll list appears.
5. Using the arrow buttons, select between **3 and 9 entries**.

On New Caller

The **On New Caller** sub-menu is used to configure what action occurs in the CWW when a new call enters the queue.

The options available for this menu are:

- | | |
|-------------------------------|--|
| <i>Select New Call</i> | When a new call enters the CWW queue, it goes to the top of the list and is then selected. The highlight moves to this item. |
| <i>Don't Select (default)</i> | When a new call enters the CWW queue, it goes to the top of the queue, but the highlighted item does not change. |

Select If Idle

When a new call comes into the CWW queue, it goes to the top of the queue list and the highlight is moved to it only if the user has not interacted with the CWW in the last 5 seconds. Or if the CWW window was not visible.

To **configure the action to take when a new call comes into the keypanel**, do the following:

1. Starting at the Service menu, select **CWW**.
2. Press the **SEL button**.
Number of Entries and On New Caller appears in the panel display.
3. Using the arrow buttons, select **On New Caller**.
4. Press the **SEL button**.
Select New Call, Select If Idle, and Don't Select appear in the panel display.
5. Using the arrow buttons, select **Select New Call, Select If Idle** or **Don't Select**.

Service Menu, Display

The **Display** menu is used to enable the menu context, display speaker volume and to switch the display to emulate a KP-32 keypanel.

Menu Context

The **Menu Context** feature is used to enable or disable the bread-crum navigation in the upper-left corner of the keypanel panel display. Breadcrumb navigation helps provide context in navigating through the keypanel menu.

Display Volume

The **Display Volume** feature is used to enable always-on display of the volume bar for Left Headset, Front Speaker, Matrix, Right Headset, or Rear Speaker, depending on what is selected from the encoder knobs.

KP32 Emulation

The **KP32 Emulation** is used to switch the display alphas and background to emulate the KP32 with the black background and green lettering.

IMPORTANT: Only the display of key and key assignment changes, the menu structure and other display elements do not revert to the KP32 display.

To **activate KP32 Emulation**, do the following:

1. Starting at the Service|Display menu, select **KP32 Emulation**.
2. Press the **SEL button**.
Disabled and Enabled appear in the panel display.
3. Using the arrow buttons, select **Enabled**.
4. Press the **SEL button**.
The display panel changes to the KP32 Emulation mode.



Service Menu, Footswitch

The **Footswitch** menu allows the user to enable the footswitch feature and configure how a latched talk key behaves when the footswitch is released. In normal footswitch operation, latched talk keys go into a ready state waiting for the footswitch to be pressed. When the footswitch is pressed, the latched talk keys become active. Then, when the footswitch is released, the latched talk keys go back into a ready state. You can configure the keypanel so latched talk keys become unlatched when the footswitch is released. In this mode, the footswitch is a one-time operation. Pressing the footswitch turns the keys on and releasing the footswitch turns the keys off, unlatching them so the keys are unable to come on again with the next press of the

footswitch. To use the footswitch again, you must re-latch the desired talk keys. For more information, “Key Options Menu, Latching” on page 217.

A footswitch is a foot-triggered switch used to activate keypanel keys.

By default, the Footswitch is *disabled*.

	Footswitch Active	The footswitch is active.
	Footswitch Enabled	NOTE: When a talk key is latched while the Footswitch is enabled, the key display turns amber  to signify it is waiting for footswitch activity.

Enabling

To **enable the footswitch**, do the following:

1. Starting at the Service|Footswitch menu, select **Mode**.
2. Press the **SEL button**.
Disabled Enabled appear in the panel display.
3. Using the arrow buttons, select **Enabled**.
4. Press the **SEL button**.
An arrow appears next to Enabled. When Footswitch is enabled, a green or yellow footswitch appears on the right side of the left panel display.

Disabling

To **disable the footswitch**, do the following

1. Starting at the Service|Footswitch menu, select **Mode**.
2. Press the **SEL button**.
Disabled Enabled appears in the panel display.
3. Using the arrow buttons, select **Disabled**.
4. Press the **SEL button**.
An arrow appears next to Disabled.

Latch Operation

To **have talk keys unlatch when the footswitch is released**, do the following:

1. Starting at the Service|Footswitch menu, select **Latched Keys**.
2. Press the **SEL button**.
Retain and Unlatch appear in the panel display.
3. Using the arrow buttons, select **Unlatch**.
4. Press the **SEL button**.
An arrow appears next to Unlatched.

To **have talk keys return to the latched state when the footswitch is released**, do the following:

1. Starting at the Service|Footswitch menu, select **Latched Keys**.
2. Press the **SEL button**.
Retain and Unlatch appear in the panel display.

3. Using the arrow buttons, select **Retain**.
4. Press the **SEL button**.
An arrow appears next to Retain.

Service Menu, Intercom Mode

The **Intercom Mode** menu is used to select the type of firmware you have in your intercom so the keypanel can display alphas in the correct font/language and modify the behavior of some functions to match the intercom behavior.

Available options are *Alternate* and *Standard*.

NOTE: Standard mode is the default and should be used in most cases. Alternate mode is primarily used for intercoms running Japanese firmware.

To **select the intercom mode**, do the following:

1. Starting at the Service|Intercom Mode menu, select **Alternate** or **Standard**.
An arrow appears next to selected option.
2. Press the **SEL button**.
The selections Cancel and Save and Restart appear.
3. Using the arrow buttons, select **Cancel** to cancel out of the action.
OR
Using the arrow buttons, select **Save and Restart** to save the changes.
4. Press the **SEL button**.

Service Menu, Key View

The **Key View** menu is used to configure the keypanel keys to show key crosspoint gains, show listen assignments, or show the matrix for each key assignment.

NOTE: Show Lstn and Show Mtx are mutually exclusive options. Only one (1) of these options may be enabled at a time.

Available options for this menu are:

<i>Show Gain</i>	The crosspoint gain bar graph for each key is shown below the talk assignment.
<i>Show Lstn</i>	The listen assignment for each key is shown above the talk assignment.
<i>Show Mtx</i>	The matrix name for each key assignment is shown above the talk assignment.

IMPORTANT: When the keypanel is configured for 8 Char or 8 Char (Unicode), none of these options are available.

To **configure the Key View**, do the following:

1. Starting at the Service menu, select **Key View**.
2. Press the **SEL button**.
Show Gain, Show Lstn, and Show Mtx appear in the panel display.
3. Using the left and right arrow buttons, select **Show Gain** to show gain on the key display.
OR
Using the left and right arrow buttons, select **Show Lstn** to show listen assignments on the key display.
OR
Using the left and right arrow buttons, select **Show Mtx** to show the matrix assignments on the key display.
4. Press the **SEL button**.
Disabled and Enabled appear in the panel display.

5. Using the left and right arrow buttons, select **Enabled** or **Disabled**.
6. Press the **SEL button**.
An arrow appears next the selected option.

Service Menu, Keypad

Keypad menu is used to configure the default function assigned to the SEL key when not in menu mode and also the keypad backlight behavior.

Backlight

The **Backlight** menu is used to select the color and brightness of the keypad backlight LEDs at various usage states and to configure the keypad mode.

Setup

The **Setup** menu allows you to configure the color and brightness of the keypad backlight LEDs various actions are performed on the keypad.

Brightness ranges from 0% to 100%.

By default, brightness is set to 30% for the Inactive state; and 100% for the Active and Shift states.

Available options for this menu are:

<i>Inactive</i>	Set the color and brightness of the keypad backlight LEDs when the keypad is in the inactive state.
<i>Active</i>	Set the color and brightness of the keypad backlight LEDs when the keypad is in the active state.
<i>Shift State</i>	Set the color and brightness of the keypad backlight LEDs when the keypad is in the SHIFT state. For more information, see “INFO button” on page 39.

Activation

The **Activation** menu is used to configure how and when the keypad backlights. When Activate is selected, the backlight activates when the user presses any keypad key on the keypad. Within the Activate menu, you can select whether the first key is processed or swallowed.

Available selections for this field are:

<i>On Keypress (swallowed)</i>	The first keypad key pushed when the keypad is Inactive is only used to activate the keypad, the actual keypad key push event is not acted upon. Note, this action activates the keypad (so the next key is processed), but it may not do anything to the backlight.
<i>On Keypress (processed)</i>	The first keypad key pushed when the keypad is Inactive, activates the keypad and then be processed.
<i>Always</i>	The keypad backlight is always in the active state.
<i>Never</i>	The keypad backlight is always in the inactive state.

NOTE: When the keypad menu is not active, the backlight stays lit for five (5) seconds of inactivity before returning to the inactive state. However, when the keypad menu is active, the backlight stays lit for one (1) minute before exiting the menu system and returning to the inactive state.

To **configure the keypad Setup option**, do the following:

1. Starting at the Service|Keypad menu, select **Backlight**.
2. Press the **SEL button**.
Activation and Setup appear in the panel display.
3. Using the left and right arrow buttons, select **Setup**.
4. Press the **SEL button**.
Inactive, Active, and Shift State appear in the panel display.
5. Using the left and right arrow buttons, select **Inactive**, **Active**, or **Shift State**.
6. Press the **SEL button**.
Blue and White appear in the panel display.
7. Using the left and right arrow buttons, select the **color** you desire.
8. Press the **SEL button**.
The Brightness scroll box appears.
9. Using the up and down arrow buttons, select the **brightness** you desire.
10. Press the **SEL button**.

To **set the keypad Activation option**, do the following:

1. Starting at the Service|Keypad menu, select **Backlight**.
2. Press the **SEL button**.
Activation and Setup appear in the panel display.
3. Using the left and right arrow buttons, select **Activation**.
4. Press the **SEL button**.
Activated (default), Always Inactive, and Always Active appear in the panel display.
5. Using the arrow buttons, select **Always On** to have the keypad backlight always on.
OR
Using the arrow buttons, select **Always Inactive** to have the keypad backlight never on.
OR
Using the arrow buttons, select **Activated** to have the keypad turn on when the keypad is pressed.

If **Activated** is selected, do the following

- a. Press the **SEL button**.
Processed First Press and Swallow First Press appear in the panel display.
 - b. Using the left and right arrow buttons, select **Processed First Press** or **Swallow First Press**.
6. Press the **SEL button**.
An arrow appears next the selected option.

SEL Key

The **SEL Key** menu allows the user to choose what function the SEL key performs when not in menu mode. This menu allows you to set up the SEL key functionality.

Available selections for this field are:

<i>Auto (default)</i>	The key function is automatically selected based on whether you are in Standard or Alternate intercom mode. In Standard mode, the SEL key is assigned Assignment Group functionality, while in Alternate mode, the SEL key is assigned Quick Assign functionality.
<i>Assignment Groups</i>	The key function is given Assignment Groups. This displays the scroll lists of a collection of user-selectable key assignments. When you select a group, a scroll list of the members of the group appear, which then can be called or programmed onto a key. For more information see, "Assignment Groups Page" on page 71.
<i>Quick Assign</i>	The key function is given Quick Assign. When you configure the SEL key with Quick Assign, you are actually selecting your most used key type, for example, P-P with AL. When the SEL key is pressed with a quick assign configured to it, a menu appears with Assign or Clear. The user can then quickly configure a key with a pre-configured assignment by selecting Assign, or clear the key assignment by selecting Clear.

To **set the configure the SEL key option**, do the following:

1. Starting at the Service|Keypad menu, select **Sel Key**.
2. Press the **SEL button**.
Auto, Assignment Groups, and Quick Assign appear in the panel display.
3. Using the arrow buttons, select **Auto** to have the keypad backlight always on.
OR
Using the arrow buttons, select **Assign Groups** to have the keypad backlight never on
OR
Using the arrow buttons, select **Quick Assign** to have the keypad turn on when the keypad is pressed.
4. Press the **SEL button**.
An arrow appears next the selected option.

Service Menu, LCD Backlight

The **LCD Backlight** menu option allows you to set the brightness of the panel display of all keypanels, just the main panel or any expansion panel connected to the main keypanel.

The range for this field is 0–100%.

The default is 65%.

To **configure the LCD backlight**, do the following:

1. Starting at the Service|Keypad menu, select **LCD Backlight**.
2. Press the **SEL button**.
The Brightness scroll box appears in the panel display.
3. Using the up and down arrow buttons, select the **brightness** you want to display.

Service Menu, Local GPIO

Local GPIO is used to configure GPIO inputs and outputs. Inputs can be assigned to activate intercom keys (including group master keys). Outputs can be activated by talk or UPG keys.

Further configuration can be done to allow GPIO Inputs to track the state of the Output. For example, an output is activated (and is being tracked by an input), the input is also activated. This feature allows GPIO Outputs to control Talk Key or Key Group activation.

In addition to tracking, you can also configure the way an Input GPIO Key Group is configured. By default, when a key group is activated, the keys are forced on until the key group is deactivated. This is referred to as Level Mode. Alternatively, you can configure the key group to Edge Mode. This option turns on keys in a key group when the group is activated, but allows the user to turn off individual keys even if the key group is still active.

To **configure a GPIO Input to control an individual talk key**, do the following:

1. Starting at the Service|Local GPIO menu, select **GPIO Inputs**.
2. Press the **SEL button**.
Opto 1 and Opto 2 appear in the panel display.
3. Using the arrow buttons, select **Opto 1** or **Opto 2**.
4. Press the **SEL button**.
Function and Mode appear in the panel display.
5. Using the arrow buttons, select **Function**.
6. Press the **SEL button**.
Key Group, Not Assigned, and Talk Key appear in the panel display.
7. Using the arrow buttons, select **Talk Key**.
8. Press the **SEL button**.
Tap Key appears in the panel display.
9. Tap the **talk key** to be controlled by the GPIO Input.
The selected keypanel key red talk indicator LED appears.

To **configure a GPIO Input to control a Key Group**, do the following:

1. Starting at the Service|Local GPIO menu, select **GPIO Inputs**.
2. Press the **SEL button**.
Opto 1 and Opto 2 appear in the panel display.
3. Using the arrow buttons, select **Opto 1** or **Opto 2**.
4. Press the **SEL button**.
Function and Mode appear in the panel display.
5. Using the arrow buttons, select **Function**.

6. Press the **SEL button**.
Key Group, Not Assigned, and Talk Key appear in the panel display.
7. Using the arrow buttons, select **Key Group**.
8. Press the **SEL button**.
Group 1, Group 2, Group 3, and Group 4 appear in the panel display.
9. Using the arrow buttons, select the **group** to be controlled by the GPIO Input.
10. Press the **SEL button**.
Level and Edge appear in the panel display.
11. Using the arrow buttons, select **Level** or **Edge**.
12. Press the **SEL button**.
An arrow appears next to the selected option.

To **setup a GPIO Input to track its corresponding GPIO Output**, do the following:

1. Starting at the Service|Local GPIO menu, select **GPIO Inputs**.
2. Press the **SEL button**.
Opto 1 and Opto 2 appear in the panel display.
3. Using the arrow buttons, select **Opto 1** or **Opto 2**.
4. Press the **SEL button**.
Function and Mode appear in the panel display.
5. Using the arrow buttons, select **Mode**.
6. Press the **SEL button**.
Normal and Track Output appear in the panel display.
7. Using the arrow buttons, select **Track Output**.
8. Press the **SEL button**.
An arrow appears next to the selected option.

To **configure local control of a GPIO Output**, do the following:

1. Starting at the Service|Local GPIO menu, select **GPIO Outputs**.
2. Press the **SEL button**.
Relay 1 and Relay 2 appear in the panel display.
3. Using the arrow buttons, select **Relay 1** or **Relay 2**.
4. Press the **SEL button**.
Not Assigned, Talk Key and UPG 1 through UPG 9 appear in the panel display.
5. Using the arrow buttons, select the **method** you want to control the GPIO Output.
If a UPG key is selected, configuration is finished.
6. Press the **SEL button**.
Tap Key appears in the panel display. If Talk Key is selected proceed to the next step.
7. Tap the **key** to be used to trigger the GPIO Output.
The selected keypanel key turns red.

Service Menu, Mirror (Control Package Only)

The **Mirror** menu provides a scroll list of keypanels which can be the target of a mirror operation. All KP-Series units can be a mirror target, a license is not required for targets.

NOTE: This menu option is not shown if the port has mirroring disabled. See “Keypanel Mirroring (Control Package Only)” on page 86.

To **take control of a target keypanel**, do the following:

1. On the keypanel, starting at the Service menu, select **Mirror**.
2. Press the **SEL button**.
A list of available target keypanels appear in the panel display.

IMPORTANT: Only panels that are locally scroll enabled are display in the available target keypanels list. If they are not in your scroll list, you cannot mirror them.

3. Using the arrow buttons, scroll to the **target keypanel**.
4. Press the **SEL button**.
The Supervisor keypanel updates and displays the target keypanel's image.

To **exit Mirror mode on the keypanel**, do the following:

1. On the keypanel, starting at the Service menu, select **Mirror**.
2. Press the **SEL button**.
The alpha of the target and Exit appear in the panel display.
3. Using the arrow buttons or Aux Volume shaft encoder, select **Exit**.
4. Press the **SEL button**.
The mirroring target and supervisor icons disappear and keypanels go back to normal operation.

Service Menu, OMNEO Setup

The **OMNEO Setup** menu option is used to configure the OMNEO device name, enable DHCP, address the OMNEO device for the keypanel and set up the static IP configuration, if DHCP is disabled.

IMPORTANT: If you change the device name on the keypanel, you must change how other devices are configured, so they can continue to make connection offers to this keypanel.

To **enable DHCP from the keypanel**, do the following:

1. Starting at the Service|OMNEO Setup menu, select **OKP**.

NOTE: OKP refers to the OMNEO keypanel using the OMNEO connection; however, if an OEI-2 is also attached to the AIO port, you see both OKP and OEI-2 options for selection.

2. Press the **SEL button**.
Device Name, DHCP, and IP Parameters appear in the panel display.
3. Using the arrow buttons, select **DHCP**.
4. Press the **SEL button**.
Disabled and Enabled appear in the panel display.
5. Using the arrow buttons, select **Enabled**.
6. Press the **SEL button**.
7. Press the **CLR** button to exit the menu.

To **configure the OKP's device name**, do the following:

1. Starting at the Service|OMNEO Setup menu, select **OKP**.
2. Press the **SEL button**.
Device Name, DHCP, and IP Parameters appear in the panel display.
3. Using the arrow buttons, select **Device Name**.
The name of the OKP card appears in the panel display with the first character of its name blinking.
4. Using the up and down arrow buttons or the Aux shaft encoder, select a **new character at the current position**.
5. Using the left and right arrow buttons or the Main shaft encoder, move to the **next or previous character position**.
6. Press **SHIFT** to insert a character at the current position.
7. Press the **SEL button**.
OR
Press the **AUX** shaft encoder to move to the next character.

NOTE: Press **BACK** or press the **MAIN** shaft encoder to cancel editing. A confirmation is required.

8. Press **FWD** or move to the end of the name and Press the **SEL button** (or the **AUX** shaft encoder) to save changes.
9. Repeat **steps 7 and 8** until you have modified the device name.
10. Press **FWD**.
The message Save Name? appears on the panel display.
11. Press the **SEL button**.

To **configure the OKP IP parameters**, do the following:

1. Starting at the Service|OMNEO Setup menu, select **OKP**.
2. Press the **SEL button**.
Device Name, DHCP, and IP Parameters appear in the panel display.
3. Using the arrow buttons, select **DHCP**.
4. Press the **SEL button**.
Disabled and Enabled appear in the panel display.
5. Verify DHCP is **disabled**.

NOTE: When making changes to the OKP IP parameters, DHCP must be disabled before changing the name or IP Address. If DHCP is enabled, you can still view the IP Parameters, but you cannot make changes to them.

6. Press **BACK**.
7. Using the arrow buttons, select **IP Parameters**.

NOTE: SEL/FWD moves to the next octet, unless already on the last octet, in which case it save the current IP Address. CLR/BACK moves to the previous octet, unless already on the first octet, in which case it cancels editing of the IP Address.

8. Press the **SEL button**.
IP Address, Gateway, Netmask, Domain, and DNS Server appear in the panel display.
9. Press the **SEL button**.
The IP Address appears with the first octet blinking in the panel display.
10. Using the number pad, enter the **first octet number** in the IP Address.
11. Press the **SEL button**.
The focus shifts to the second octet.
12. Using the number pad, enter the **second octet number** in the IP Address.
13. Press the **SEL button**.
The focus shifts to the third octet.
14. Using the number pad, enter the **third octet number** in the IP Address.
15. Press the **SEL button**.
The focus shifts to the last octet.
16. Using the number pad, enter the **last octet number** in the IP Address.
17. Press the **SEL button**.
The OKP Setup menu options appear in the panel display.

To **configure the Gateway Address**, do the following:

1. Using the arrow buttons, select **Gateway**.
2. Press the **SEL button**.
The Gateway Address appears with the first octet blinking in the panel display.
3. Using the number pad, enter the **first octet number** in the Gateway Address.
4. Press the **SEL button**.
The focus shifts to the second octet.
5. Using the number pad, enter the **second octet number** in the Gateway Address.
6. Press the **SEL button**.
The focus shifts to the third octet.
7. Using the number pad, enter the **third octet number** in the Gateway Address.
8. Press the **SEL button**.
The focus shifts to the last octet.
9. Using the number pad, enter the **last octet number** in the Gateway Address.
10. Press the **SEL button**.
The OKP Setup menu options appear in the panel display.

To **configure the Netmask Address**, do the following:

1. Using the arrow buttons, select **Netmask**.
2. Press the **SEL button**.
The Netmask Address appears with the first octet blinking in the panel display.
3. Using the number pad, enter the **first octet number** in the Netmask Address.
4. Press the **SEL button**.
The focus shifts to the second octet.
5. Using the number pad, enter the **second octet number** in the Netmask Address.
6. Press the **SEL button**.
The focus shifts to the third octet.
7. Using the number pad, enter the **third octet number** in the Netmask Address.
8. Press the **SEL button**.
The focus shifts to the last octet.
9. Using the number pad, enter the **last octet number** in the Netmask Address.
10. Press the **SEL button**.
The OKP Setup menu options appear in the panel display.

To **configure the Domain name**, do the following:

1. Using the arrow buttons, select **Domain**.
2. Press the **SEL button**.
The domain name appears with the first character blinking in the panel display.
3. Using the up and down arrow buttons or the Aux shaft encoder, select a **new character at the current position**.
4. Using the left and right arrow buttons or the Main shaft encoder, move to the **next or previous character position**.
5. Press **SHIFT** to insert a character at the current position.
6. Press the **SEL button**
OR
Press the **AUX** shaft encoder to move to the next character.

NOTE: Press **BACK** or press the **MAIN** shaft encoder to cancel editing. A confirmation is required.

7. Press **FWD** or move to the end of the name and Press the **SEL** button (or the **AUX** shaft encoder) to save changes.
8. Repeat **steps 3 to 7** until the domain is named.

9. Once finished, press the **FWD** button.
Save Name? appears in the panel display.
10. Press the **SEL** button.

To **configure DNS Server**, do the following:

1. Using the arrow buttons, select **DNS Server**.
2. Press the **SEL** button.
The DNS 1 Server Address appears with the first octet blinking in the panel display.
3. Using the number pad, enter the **first octet number** in the DNS Address.
4. Press the **SEL** button.
The focus shifts to the second octet.
5. Using the number pad, enter the **second octet number** in the DNS Address.
6. Press the **SEL** button.
The focus shifts to the third octet.
7. Using the number pad, enter the **third octet number** in the DNS Address.
8. Press the **SEL** button.
The focus shifts to the last octet.
9. Using the number pad, enter the **last octet number** in the DNS Address.
10. Press the **SEL** button.
The OKP Setup menu options appear in the panel display.

Service Menu, Page Change

Page Change is used to select whether you are allowed to change setup pages while talk keys are active. By default, in Standard Intercom Mode, page changes are allowed when talk keys are active. However, the default in Alternate Intercom Mode does not allow page changes to occur when talk keys are active.

Available options:

<i>Auto</i>	The default is followed depending on the Intercom Mode: Standard or Alternate.
<i>Always Allow</i>	Page changes are allowed while Talk Keys are active.
<i>No Talk Keys</i>	Page changes are not allowed while Talk Keys are active. A red bar appears above/below the keys signifying page changes are not allowed. If the talk key is turned off, the red bar turns blue and page changes can be done.

To **configure page change operation**, do the following:

1. Starting at the Service|Page Change menu, select **Page Change**.
2. Press the **SEL** button.
Auto, Always Allow, and No Talk Keys appear.
3. Using the arrow buttons, select the **page change option** you desire.
4. Press the **SEL** button.
An arrow appears next to the selected option.

Service Menu, Reset Cfg

Reset Cfg restores almost all custom settings to the defaults and erases all stored autodial numbers. Reset Cfg does not change the selected alpha size, intercom mode, poll ID, headset transfer state, or reset the IP configuration.

To **reset the keypanel configuration**, do the following:

1. Starting at the Service|Reset Cfg menu, select **Do Reset**.
2. Press the **SEL button**.
Configuration Reset appears in the panel display.

Service Menu, Scrn Saver

Scrn Saver allows the user to configure the way the screen saver feature operates.

Available selections for this menu are:

<i>Activate</i>	Allows the user to activate the screen saver immediately (used to test current display settings).
<i>Delay</i>	Allows the user to set the delay for Display Dim (for example, when the display will dim) and to set the delay for Activation (for example, when the screen saver becomes active). Both features can be set from 30 minutes, up to 12 hours, or disabled.
<i>Display Dim</i>	Allows the user to set the brightness of the panel display from 0-100%. This setting is a percentage of the current LCD brightness. For example, if you configured your backlight for 60%, then in this menu, 100% is equal to 60% and 0% is equal to 35%.
<i>Mode</i>	Can be set to Bitmap, Display Off (sleep mode), or Text.

The default setting for this option is:

<i>Delay</i>	One (1) hour for both display dim and screen-saver activation
<i>Display Dim</i>	25%
<i>Mode</i>	Text

NOTE: Activating any lever key, keypad button, or shaft encoder deactivates the screen-saver, as will an incoming call.

To **manually activate the screen saver**, do the following:

1. Starting at the Service|Scrn Saver menu, select **Activate**.
2. Press the **SEL button**.
The screen saver is activated on the keypanel panel display.

To **set the delay option for the keypanel screen saver**, do the following:

1. Starting at the Service|Scrn Saver menu, select **Delay**.
2. Press the **SEL button**.
Display Dim and Activation appear in panel display.
3. Using the left and right arrow buttons, select **Display Dim**.
4. Press the **SEL button**.
The Delay Time: scroll box appears in the panel display.
5. Using the arrow buttons, select the **amount of time** you want to expire before the display dims.
6. Press **BACK**.
Display Dim and Activation appear in panel display.
7. Using the left and right arrow buttons, select **Activation**.

8. Press the **SEL button**.
The Delay Time: scroll box appears in the panel display.
9. Using the arrow buttons, select the **amount of time** you want to expire before the screen saver becomes active.

To **set the brightness of the display**, do the following:

1. Starting at the Service|Scrn Saver menu, select **Display Dim**.
2. Press the **SEL button**.
The Brightness scroll box appears in the panel display.
3. Using the up and down arrow buttons, scroll to the **display brightness** you desire.

To **set the screen saver mode (type)**, do the following:

1. Starting at the Service|Scrn Saver menu, select **Mode**.
2. Press the **SEL button**.
Bitmap, Display Off and Text appear in the panel display.
3. Using the arrow buttons, select **Bitmap** to have a bitmap image display when the screen saver activates.
OR
Using the arrow buttons, select **Display Off** to put the display into sleep mode when the screen saver activates.
OR
Using the arrow buttons, select **Text** to have a text message display when the screen saver activates.
4. Press the **SEL button**.
If Bitmap or Text is selected, the options Bounce or Scroll appear.
5. Using the arrow buttons, select **Bounce** to have the bitmap or text bounce across the display.
OR
Using the arrow buttons, select **Scroll** to have the bitmap or text scroll across the display.

Service Menu, Set Address

Set Address is used to indicate the poll ID of the keypanel. See “DKP-4016/4016W Addressing” on page 25 to determine if you need to set the keypanel address. The poll ID is the number (or address) at which an AIO card or intercom attempts to communicate with the keypanel. The Poll ID number is directly related to the connection port on the breakout panel.

Available options for the Poll ID are 1–8.

To **set the address**, do the following:

1. Starting at the Service|Set Address menu, select the **poll ID** for the keypanel.
2. Press the **SEL button**.
Cancel or Save and Restart appear in the panel display.
3. Using the arrow buttons, scroll to **Save and Restart**.
4. Press the **SEL button**.
Restarting.... appears. The keypanel resets. Once the restart is complete, the Poll ID is enabled.

Service Menu, Snoop Tally

Snoop Tally, when enabled, indicates to keypanel users somebody is listening to them. For example, snoop tallies are displayed on keypanel 1, if there is another keypanel (2) which is listening to keypanel 1 via a point-to-point or a special list, but is not talking to keypanel 1. Snoop tallies are suppressed if keypanel 1 has any talk keys turned on, or if the hot mic is not enabled.

From this menu, you can set the type of chime indication you want and the duration of the tally.

Available Tally durations available are: *One-shot* and *1 second to 5 minutes*.

NOTE: Hot Mic must be activated on the keypanel for snoop tally to work. For more information, see “Audio Options Menu, Matrix Out” on page 196.

By default, snoop tally is *disabled* (no chime).



To **enable snoop tallies on the keypanel**, do the following:

1. Starting at the Service menu, select **Snoop Tally**.
2. Press the **SEL button**.
The Chime scroll box and the Duration scroll appear in the panel display.
3. Using the up and down arrow buttons, select the **type of chime** you desire.
4. Using the left and right arrow buttons, select **Duration**.
5. Using the up and down arrow buttons, select the **duration** of the tally.

Service Menu, Test Panel

Test Panel allows the user to check the operation of all keys and displays on the keypad.

TABLE 10. Test Panel Key Descriptions

<i>Display</i>	<i>Action</i>
	All alpha numeric displays show a % symbol when in Test Panel mode.
	Press down on any key.
	Press up on any key.
	Press to the right on any key (excluding the MIC MUTE/MIC SEL and CLR/CWW).
	Press to the left on any key (excluding the MIC MUTE/MIC SEL. and CLR/CWW).
<AUX>	Single tap the Aux Volume encoder knob.
<-AUX>	Rotate the Aux Volume encoder knob counterclockwise.
<+AUX>	Rotate the Aux Volume encoder knob clockwise.
<AUX-DBL>	Double tap the Aux Volume encoder knob.
<AUX-HELD>	Press and hold the Aux Volume encoder knob.
<MAIN>	Single tap the Main Volume encoder knob.
<-MAIN>	Rotate the Main Volume encoder knob counterclockwise.
<+MAIN>	Rotate the Main Volume encoder knob clockwise.
<MAIN-DBL>	Double tap the Main Volume encoder knob.
<MAIN-HELD>	Press and hold the Main Volume encoder knob.
<-MIC>	Press left on the MIC MUTE/MIC SEL. key.
<+MIC>	Press right on the MIC MUTE/MIC SEL. key.
<MUTE>	Press up on the MIC MUTE/MIC SEL. key.
<MIC>	Press down on the MIC MUTE/MIC SEL. key.
<-CWW>	Press left on the CLR/CWW key.
<+CWW>	Press right on the CLR/CWW key.
<CLR>	Press up on the CLR/CWW key.
<CWW>	Press down on the CLR/CWW key.
<Menu>	Press the MENU button.
<Fwd>	Press the FWD button.
<Back>	Press the BACK button.
<UPG3>	Press the UPG3 button.
<UPG4>	Press the UPG4 button.

To **enable the test panel**, do the following:

1. On the keypanel keypad, press **MENU**.
The Information menu appears in the panel display.
2. Using the arrow buttons, select **Service**.
3. Press the **SEL button**.
The Service submenu appears in the panel display.
4. Using the arrow buttons, select **Test Panel**.
5. Press the **SEL button**.
The Test Panel display appears.
6. Using Table 10 on page 242, test the **keypanel keys**.
7. Press the **CLR button** to exit Test Panel.

Telephone Interface (TIF) Operation

NOTE: Telephone operation requires an optional **TIF** (Telephone Interface). You must assign an intercom key to talk/listen to the TIF. We recommend a talk + auto follow assignment. See the TIF User Manual (PN F01U193285) for specific TIF configuration options.

Receiving A Phone Call

When there is an incoming telephone call, the TIF alpha begins to tally.

To **receive a phone call**, do the following:

- > Press the **key** to answer the call.

NOTE: TIF assignments tally when the phone is ringing. By default, the assignments also tally while the phone is off-hook. This operation can be disabled by selecting the *Don't generate tallies for off-hook TIF assignments* checkbox in AZedit (Options|Intercom Configuration|Options page) or by editing the Enhanced Tally definitions for the TIF Off-hook and TIF ringing tally types.

Dialing and Hanging Up

NOTE: Auto Dial only appears in the TIF menu options when auto dial numbers are configured.

Manual Dial

NOTE: You can enter manual dial mode by pressing SHIFT+DIAL and then tapping the TIF assignment.

To **manually dial**, do the following:

1. On the keypad, lift the **TIF key** up to turn listen on.
2. Press the **TIF key** down to turn the Talk key on.
Auto Dial, Hang Up, Manual Dial, and Redial appear in the panel display.

NOTE: This only happens if the assignment port is marked as Port is TIF in AZedit.

3. Using the arrow buttons, select **Manual Dial**.
4. Press the **SEL button**.
Dial: appears in the panel display.
5. Using the keypad, dial the **number** you want to call.
6. Press the **SEL button**.
The call is placed.

Keypanel Hang Up

NOTE: You can also hang up a TIF by pressing SHIFT+DROP, and then tapping the TIF assignment.

To **hang up the telephone**, do the following:

1. On the keypanel, press the **TIF key** down to turn it on.
Auto Dial, Hang Up, Manual Dial, and Redial appear in the panel display.
2. Using the arrow buttons, select **Hang Up**.
3. Press the **SEL button**.
The call is disconnected.

To **program a keypanel UPG key to activate the TIF key**, do the following:

1. Press the **SHIFT + DIAL keys**.
2. Press and hold the desired **UPG button** to which you want to program the TIF activation.
The message Menu position saved appears and the TIF activation is assigned to the key.

To **redial a phone number**, do the following:

1. On the keypanel, press the **TIF listen key** on.
2. On the keypanel, press the **TIF talk key** on.
Auto Dial, Hang Up, Manual Dial, and Redial appear in the panel display.
3. Using the arrow buttons, select **Redial**.
4. Press the **SEL button**.
The last dialed number is connected. The TIF key alpha flashes and Hang Up appears in the panel display.
5. Press the **SEL button** to disconnect the call.
The call is ended.

To **program a keypanel UPG key to hang up the TIF key**, do the following:

1. Press the **SHIFT + DIAL keys**.
2. Press and hold the desired **UPG button** to which you want to program Hang Up.
The message Menu position saved appears and the TIF activation is assigned to the key.

Auto Dial

To **autodial a phone number**, do the following:

1. On the keypanel, press the **TIF listen key** on.
2. On the keypanel, press the **TIF talk key** on.
Auto Dial, Hang Up, Manual Dial, and Redial appear in the panel display.
3. Using the arrow buttons, select **Auto Dial**.
4. Press the **SEL button**.
The Auto Dial numbers appear in the panel display.
5. Using the arrow buttons, select the **Auto Dial number** you want to call.
6. Press the **SEL button**.
The call is placed. The TIF key alpha flashes and Hang Up appears in the panel display.

Centralized Auto Dials

The **Centralized Auto Dials** allows up to 999 phone numbers to be stored in the intercom as a scrollable list from the keypanels. Auto dials are telephone numbers frequently dialed and are maintained using the AZedit Intercom Configuration Software. Customizing auto dial numbers in AZedit is as easy as entering the telephone number and selecting whether or not it is scroll enabled.

The following firmware versions must be loaded to utilize centralized auto dials in your intercom system:

- AZedit Intercom Software V3.6.1 or later
- MCII-e V2.0.4 or later
- PeriphII-e (Ethernet) V1.20.0 or later
- Periph Controller (Standard) V10.20.0 or later
- DBX V1.20.0 or later
- Cronus Firmware V1.5 or later
- Zeus II Firmware V3.4.0 or later
- Zeus III Firmware V1.0.0 or later
- DKP-4016 Firmware V1.1.0 or later

Centralized Auto Dial

The **Centralized Auto Dial** can be used two (2) different ways, with TIF assignments or with keypad sequences. You can also configure locally stored auto dial numbers on the keypanel. For more information, see “Key Options Menu, Auto Dial” on page 213.

To **access the Auto Dials window**, do the following:

- > From the System menu in AZedit, select **Auto Dial**.
The Auto Dials window appears.

Auto Dial	Alpha	LC	Phone Number
001	AD01	LC	
002	AD02	LC	
003	AD03	LC	
004	AD04	LC	
005	AD05	LC	
006	AD06	LC	
007	AD07	LC	
008	AD08	LC	
009	AD09	LC	
010	AD10	LC	

To **add a telephone number to the Auto Dial database**, do the following:

1. From the System menu in AZedit, select **Auto Dial**.
The Auto Dial window appears.
2. From the Auto Dial column, double-click an **auto dial number**.
The Edit Auto Dial window appears.

3. From the Scroll Enable group box, select the **scroll enable check boxes** you want to configure for the auto dial number.
4. In the Phone Number field, enter the **telephone number** you want to have for that auto dial sequence.

NOTE: Entering *99 creates a pause in dialing. This is used to dial extensions or select preset options.

5. Click **Next** to enter another number.
The next blank Edit Auto Dials window appears.
OR
Click **Done** to close the Edit Auto Dial window.
The Auto Dials window appears with the new number in the list.

To **add a description to the telephone number you added to the Auto Dial database**, do the following:

1. From the Alphas menu in AZedit, select **Auto Dial**.
The Auto Dial Alphas window appears.
2. Double-click the **AD resource number** to which you want to add the description.
The Edit Alpha/Description window appears.

3. In the Description field, enter a **unique description** for the auto dial number. For example, Studio 1A NYC.
4. In the Alpha 4, Alpha 6, or Alpha 8 field, enter a **recognizable 4-, 6- or 8-character Alpha**. For example, 1ANY.

5. Click **Done** when you are finished.
OR
Click **Next** to enter another Alpha Description.

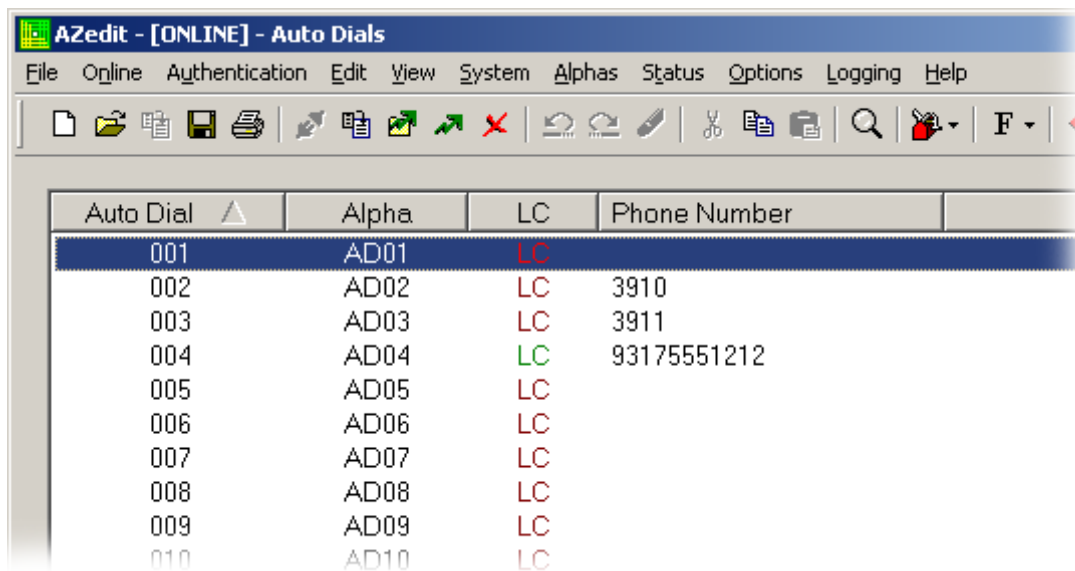

The screenshot shows the AZedit software interface with a menu bar (File, Online, Authentication, Edit, View, System, Alphas, Status, Options, Logging, Help) and a toolbar. Below the toolbar is a table with the following data:

Auto Dial	Alpha	LC	Phone Number
001	AD01	LC	
002	AD02	LC	3910
003	AD03	LC	3911
004	AD04	LC	93175551212
005	AD05	LC	
006	AD06	LC	
007	AD07	LC	
008	AD08	LC	
009	AD09	LC	
010	AD10	LC	

6. From the Online menu in AZedit, select **Send Changes**.
The Send Changes window appears.
7. Click **OK**.
The changes are sent to the intercom and the telephone number is added to the intercom system auto dial table.

To use **centralized auto dial numbers**, do the following:

1. On the keypanel, press the **TIF assignment key**.
Hang Up, Icom ADial, Manual Dial, and Redial appear in the panel display.
2. Using the arrow buttons, scroll to **Icom ADial**.
3. Press the **SEL button**.
You enter the centralized auto dial list. A scrollable list of available Auto Dial numbers appear in the panel display.
4. Using the arrow buttons, scroll to the desired **auto dial number**.
5. Press the **SEL button**.
The number connects.

To use **centralized auto dial numbers with keypanel keypad sequences**, do the following:

1. Press the **SHIFT + DIAL keys**.
Tap Key appears in the panel display.
2. Press the **TIF assignment key**.
A dial tone is heard.
3. Using the keypad, enter #NNN (where NNN is the Auto Dial number assignment in AZedit).
The number is dialed.

Keypad Quick Reference

Keypad Sequence Introduction

Keypad sequences are a series of keypad strokes made on the keypad, which in turn displays specific information (such as keypad ID, talk level 2 assignments, etc.). Keypad sequences are shortcuts via the keypad keypad.

As with other keypads, the DKP-4016/4016W allows you to lock the entire menu or only the service menu. This is implemented through AZedit (System|Miscellaneous|Keypad Menu Password). For more information, see the AZedit user manual (p/n F01U239453).

Keypad Sequences



<i>Keypad</i>	<i>Description</i>
MENU	Open the main menu
FWD	Move one (1) selection forward through highlighted menu option
BACK	Move one (1) selection backwards through highlighted menu option
LOC	Display a list of available intercoms available to scroll from
Arrow Up	Scroll upward through scroll list or available key assignments one at a time
Arrow Left	Move backwards through menu options or available key assignments one at a time
MENU (middle of the keypad)	Open the main menu
Arrow Right	Move forward through menu options or available key assignments one at a time
COPY	Copy incoming call key assignment from the CWW
Down Arrow	Scroll downward through scroll list or available key assignments one at a time
PAGE	Access setup pages
CLR	Clear the CWW (Acts as a BACK button in menu mode, or by holding it down, exits the menu structure.)
SHIFT	Access secondary keypad actions
SEL	Select options highlighted in a menu
SHIFT+LOC	Displays the keypad assignment types
SHIFT+4	Move backwards through menu options or available key assignments a page at a time
SHIFT+INFO	Open the INFO menu
SHIFT+6	Move forward through menu options or available key assignments a page at a time
SHIFT+DROP, <key>	Hang up TIF on key
SHIFT+DIAL, <key>	Enter dial mode on TIF on key

Keypad Sequences	
7,<key>	Copy the CWW to a key
0,0,0,8,1	Show panel ID
0,0,0,8,2	Show talk level 2 assignments
0,0,0,8,3	Show listen assignments
0,0,0,8,7	Enable tone
0,0,0,8,0	Enter test mode
0,0,3,1,SEL,<listen key>	Program a listen key with an AL assignment
0,0,3,2,SEL,<listen key>	Program a listen key with an AF assignment
0,0,3,3,SEL,<listen key>	Program a listen key with an AM assignment
0,0,3,4,SEL,<listen key>	Program a listen key with an AR assignment
0,0,3,7,SEL,<listen key>	Program a listen key with an AT assignment
0,0,3,5,SEL,<talk key>	Program a talk key with an AC assignment
0,0,0,8,8	Show setup pages
0,7,<key>,<key> or 7, SEL, <key>, <key>	Copy the first key to the second key
9, <page>, SEL <key>	Select setup page for row of keys
2 (up) or 4 (left)	Enter scroll list mode, scroll up/left
8 (down) or 6 (right)	Enter scroll list mode, scroll down/right
The following sequences also require the assignments are marked as Local scroll enable in AZedit:	
NOTE: IFB, ISO, RY, and IFSL are not locally scrollable, by default.	
0,0,1, <port>,SEL,<key>	Program a key with a port assignment
0,0,2, <PL num>, SEL,<key>	Program a key with a PL assignment
0,0,0,1, <SL num>,SEL,<key>	Program a key with a SL assignment
0,0,0,2, <IFB num>,SEL,<key>	Program a key with an IFB assignment
0,0,0,3, <ISO num>,SEL, <key>	Program a key with an ISO assignment
0,0,0,4, <RY num>,SEL,<key>	Program a key with an RY assignment
0,0,0,5,2 <IFB SL num>,SEL,<key>	Program a key with an IFB SL assignment

Keypanel Menu Quick Reference

Audio Options

Advanced			
AEC			
Mic Priority			
		Front Mic (default)	
		Rear Mic	
AGC			
Attack			
	Front Mic Left Hdst Rear Mic Right Hdst	Fast Attack Speed	0.5ms 1ms (default) 2ms
Decay			
	Front Mic Left Hdst Rear Mic Right Hdst	Decay	500ms (default) 750ms 1000ms
Compression			
	Front Mic Left Hdst Rear Mic Right Hdst	Compression Ratio:	1:1 2:1 3:1(default) 4:1 (only available with Audio Package) 5:1 (only available with Audio Package) 6:1 (only available with Audio Package)
Filters			
Bandpass			
		Inputs	
		Aux 1 OMNEO 1 OMNEO 2 OMNEO 3-8 (only available with Audio Package)	

		Frequencies	
		Low Freq	0 Hz (default) 15.6Hz 31.5Hz 50Hz
		High Freq	22kHz (default) 16kHz 8KHz 4KHz
		Mode	
		Disabled (default)	
		Enabled	
Outputs			
Left Hdst	Both		
Right Hdst	Left Chan		
	Right Chan		
		Frequencies	
		Low Freq	
			0 Hz (default) 15.6Hz 31.5Hz 50Hz
		High Freq	
			22kHz (default) 16kHz 8KHz 4KHz
		Mode	
		Disabled (default)	
		Enabled	
Matrix Out			
OMNEO 1			
OMNEO 2			
OMNEO 3-8 (only available with Audio Package)			
Preamp Out			
		Frequencies	
		Low Freq	
			0 Hz (default) 15.6Hz 31.5Hz 50Hz
		High Freq	
			22kHz (default) 16kHz 8KHz 4KHz
		Mode	
		Disabled (default)	
		Enabled	

Equalization			
Inputs			
Front Mic Left Hdst Matrix Rear Mic Right Hdst	Modes	Disabled (default) Enabled	
	Presets	Default (default) Hiss Reduction Rumble Reduction Noise Reduction	
Outputs			
Front Spkr Rear Spkr	Modes	Disabled (default) Enabled	
	Presets	Default (default) Hiss Reduction Rumble Reduction Noise Reduction	
Notch			
Notch Filter			
		Disabled (default) Narrow Default Wide	
Gating			
Aux 1 Front Mic Left Hdst Matrix In OMNEO 1 OMNEO 2 OMNEO 3-8 (only available with Audio Package) Rear Mic Right Hdst			
		Threshold	
		Disabled (default) -17dB – 18dB	
Metering			
Aux 1 Front Mic Left Hdst Matrix In None (default) OMNEO 1 OMNEO 2 OMNEO 3-8 (only available with Audio Package) Rear Mic Right Hdst			

Mixing			
	Left Hdst Right Hdst	Both Left Chan Right Chan	Aux 1 Front Mic Left Hdst OMNEO 1 OMNEO 2 OMNEO 3-8 (only available with Audio Package) Rear Mic Right Hdst
	Front Spkr OMNEO 1 OMNEO 2 Rear Spkr		Aux 1 Front Mic Left Hdst Matrix In OMNEO 1 OMNEO 2 OMNEO 3-8 (only available with Audio Package) Rear Mic Right Hdst
	Preamp Out To Matrix		Aux 1 Matrix In OMNEO 1 OMNEO 2 OMNEO 3-8 (only available with Audio Package)
Mix Mode			
	Aux Mixes Switched (default)		
	Mixes Always Active		
Noise Gate			
	Front Mic		
	Left Hdst	Disabled (default)	
	Rear Mic	Enabled	
	Right Hdst		
Chime			
Preview			
	Yes (default)		
	No		
Chime			
	System #1-12		
	User #1-4 (only available with Audio Package)		
Volume			
	-20dB (default)		
	-60dB – 10dB		
Dim			
Headset			
	Left Right	Dim Amount:	0dB (default) -32dB – 0dB
Speaker			
	Front Rear	Dim Amount:	-8dB (default) -48dB – 0dB Mute
Ganged Vols			
	Disappearing (default)		
	Fixed Offset		
Headset Mic			

Left	Auto-Mute	Disabled Enabled (default)	
	Mode	Disabled Enabled Switched (default)	
	Type	Auto-Detect (default) Dynamic Electret	
Right	Auto-Mute	Disabled Enabled (default)	
	Mode	Disabled Enabled Switched (default)	
	Type	Auto-Detect (default) Dynamic Electret	
Headset Spkr			
Left	Auto-Transfer	Disabled Enabled (default)	
	Mode	Both, Left Chan Right Chan	Always On (default) Disabled Switched
Right	Auto-Transfer	Disabled Enabled (default)	
	Mode	Both, Left Chan Right Chan	Always On (default) Disabled Switched
Volume Control			
	Ganged Individual (default)		
Inputs			
Aux 1			
	Disabled Enabled (default)		
Matrix In			
	Disabled Enabled (default)		
OMNEO 1			
	Disabled Enabled (default)		
OMNEO 2			
	Disabled Enabled (default)		
OMNEO 3			
	Disabled Enabled (default)		
OMNEO 4			
	Disabled Enabled (default) Ganged		

OMNEO 5		
	Disabled Enabled (default)	
OMNEO 6		
	Disabled Enabled (default) Ganged	
OMNEO 7		
	Disabled Enabled (default)	
OMNEO 8		
	Disabled Enabled (default) Ganged	
Key Volumes		
Adjust		
	Disabled Enabled (default)	
Minimum		
	Adjust Minimum Key Volumes	
Reset		
	Cancel Do Reset	
	Volumes Reset	
Matrix Out		
Hot Mic		
Normal (default)		
Max Volume		
Headset	Left Right	Max Volume: -48dB – 10dB (default), Mute
Speaker	Front Rear	
Mic Gain		
Adjust		
	Disabled (default) Front Mic Left Hdst Rear Mic Right Hdst	
Level		
	Front Mic Left Hdst Rear Mic Right Hdst	Mic Gain: 0dB (default) -20dB – 10dB
Mic Mute		
Disabled		
Momentary		
Toggle (default)		
Min Volume		

Headset	Left Right	Min Volume: -6dB is the default for Matrix In, while Mute is the default for all other options Mute, -48dB – 10dB
Speaker	Front Rear	
Aux 1		
Matrix In OMNEO 1 OMNEO 2 OMNEO 3-8 (only available with Audio Package)		
Output Level		
Output Level:	8dB (default) – 0dB	
Panel Mic		
Front	Disabled Enabled Switched (default)	
Rear	Disabled (default) Enabled Switched	
Preamp Out		
Disabled Hot Mic Invert Switched (default)		
Sidetone		
Level	Sidetone Level: -20dB (default), -65dB to 0dB	
Mode	Always On Disabled Switched (default)	
Speaker		
Front	Always On Disabled Switched (default)	
Rear	Always On Disabled (default) Switched	
Volume Control	Ganged Individual (default)	
Tone Gen		
Frequency	1KHz Tone 500Hz Tone (default)	
Tone Off (default)		
Tone On		

VM Options	
Playback	
	Isolate
	Mix (default)
Recording	
	Auto Recording
	Disabled (default)
	Rolling Buffer
	When Mailbox Full
	Delete Oldest
	Reject New (default)

Display Menu

Assign Type	Shows key's assignment types
Auto Dial	Shows keys with 1-Touch Auto Dial assigned
Chans On	Shows scroll list of current callers
Chime	Shows keys with Chime assigned
Exclusive	Shows which keys are Exclusive keys
Key Groups	Group 1 - shows which key is Master, and which keys are Group Slaves Group 2 - shows which key is Master, and which keys are Group Slaves Group 3 - shows which key is Master, and which keys are Group Slaves Group 4 - shows which key is Master, and which keys are Group Slaves
Key List	Shows scroll list of hidden key assignments assigned to virtual keys
Level 2	Level 2 Assignments - Shows the talk level 2 assignment for each key assignment
Listen	Listen Assignments - Shows the listen assignment for each key assignment
MAC Address	MAC Address - shows the keypanel MAC Address
Matrix	Key Assignment Matrices - Shows the matrix for each key assignment
Panel ID	<Panel ID> - Shows the port number and alpha for this keypanel
Solo Key	Solo Keys - Shows which key is the solo key
Version	Version X.X.X - shows the keypanel firmware version

Key Assign Menu

Matrix (only displays if there are remote matrices. Selecting Matrix displays a list of remote intercoms.)	<Ports/Assignments>	Listen Talk Lvl1 Talk Lvl2 Talk+AF Talk+AL Talk+AM Talk+AR Talk+AT	Tap Key
Pt-to-Pt			
Party Line			
IFB			
Special List			
Sys Relay			
Camera ISO			
UPL Resource			
IFB Spcl List			
Auto Funcs			

Key Options Menu

Auto Dial	
Numbers	#01 – #100
1-Touch	Tap Key
Chime	
Chime	<none> System #1 System #2 System #3 System #4 System #5 System #6 System #7 System #8 System #9 System #10 System #11 System #12 User #1 (only available with Audio Package) User #2 (only available with Audio Package) User #3 (only available with Audio Package) User #4 (only available with Audio Package)
Duration	One-shot (default) 1 second 2 seconds 3 seconds 4 seconds 5 seconds 10 seconds 15 seconds 20 seconds 30 seconds 60 seconds 90 seconds 2 minutes 3 minutes 4 minutes 5 minutes
Clear	
Tap Key	
Exclusive	
Tap Key	
Icons	
Icon	Key has TIF Asgn Key is Solo Key Key is Exclusive Key Key has Auto-Dial Key is Group Master

	Key has Chime	
	Key has Trunk Asgn	
Display	Disabled	
	Enabled (default)	
Key Groups		
Group 1	Tap Master Key	Tap Slave Key
Group 2		
Group 3		
Group 4		
Latching		
Global		
	Disabled	
	Enabled (default)	
Per Key		
	Tap Key	
Lock		
	Tap Key	
Panel Swap		
Control		
GPI Inputs		
	Opto 1	
	Opto 2	
	Cycle To	Next Previous
	Switch To	MAIN EKP 1 - EKP 7
	Toggle To	EKP 1 - EKP 7
	Unassigned (default)	
GPI Outputs		
	Relay 1	
	Relay 2	
	Cycle To	Next Previous
	Switch To	MAIN EKP 1 - EKP 7
	Toggle To	EKP 1 - EKP 7
	Unassigned (default)	
Keypad		
	BACK	
	FWD	
	UPG 1 - UPG9	
	Cycle To	Next Previous
	Switch To	MAIN EKP 1 - EKP 7
	Toggle To	EKP 1 - EKP 7
	Unassigned	
Key States		
	Force Off (default)	
	Retain	

Virtual EKPS	
	None
	1 EKP through 6 EKPs for DKP-4016
Solo	
	Tap Key
Tallies	
	Indefinite
	Disabled (default)
	Enabled
	Min Duration
	Min Duration:
	5 seconds
	10 seconds
	15 seconds (default)
Turn Off	
	All Keys
	Turn Keys Off?
	Keys Turned Off
	Talk Keys
	Turn Keys Off?
	Keys Turned Off
	Listen Keys
	Turn Keys Off?
	Keys Turned Off

OMNEO Offers Menu

Keypanel	
OKP	
	<Port #> - Shows a list of all OMNEO offers
AIO - If an RVON-IO or an OEI-2 is connected, it shows that device instead	
	Disabled
	Enabled (default)
Aux Input	
OMNEO 1	
	<Port #> - Shows a list of all OMNEO offers
OMNEO 2	
	<Port #> - Shows a list of all OMNEO offers
OMNEO 3	
	<Port #> - Shows a list of all OMNEO offers
OMNEO 4	
	<Port #> - Shows a list of all OMNEO offers
OMNEO 5	
	<Port #> - Shows a list of all OMNEO offers
OMNEO 6	
	<Port #> - Shows a list of all OMNEO offers
OMNEO 7	
	<Port #> - Shows a list of all OMNEO offers
OMNEO 8	
	<Port #> - Shows a list of all OMNEO offers

Save Config Menu

Configuration Saved

Service Menu

Alphas	
	4 Chars (default)
	6 Chars
	8 Chars
	8 Chars (Unicode)
Aux Select	
	Number of Analog Inputs 0
	Number of Analog Inputs 1
CWW	
	Number of Entries
	3 through 9
	On New Caller
	Don't Select
	Select If Idle
	Select New Call
Display	
	Menu Context
	Disabled
	Enabled (default)
	Show Volume
	Disabled (default)
	Enabled
	KP32 Emulation
	Disabled (default)
	Enabled
Footswitch	
	Mode
	Disabled (default)
	Enabled
	Latched Keys
	Retain (default)
	Unlatch
Intercom Mode	
	Alternate
	Standard (default)
Key View	
	Show Gain
	Disabled (default)
	Enabled
	Show Lstn
	Disabled (default)
	Enabled
	Enabled (Suppress Auto)
	Show Mtx
	Disabled (default)
	Enabled
	Enabled (Suppress Local)

Keypad						
SEL Key						
Auto (default)						
Assign Groups						
Quick Assign						
Backlight						
Activation						
Activate						
On Keypress (swallowed) (default)						
On Keypress (processed)						
Always						
Never						
Setup						
Inactive						
Brightness: ##% (default is 30%)						
Color:						
Blue (default)						
White						
Active						
Brightness: ##% (default is 100%)						
Color:						
Blue (default)						
White						
Shift State						
Brightness: ##% (default is 100%)						
Color:						
Blue						
White (default)						
LCD Backlight						
Brightness:						
65% (default)						
35% – 100%						
Local GPIO						
GPIO Inputs						
Opto1 Opto2	Function	Key Group	Group 1	Level	Cancel	
			Group 2		Save and Restart	
	Mode	Key Group	Group 3	Edge	Cancel	
			Group 4		Save and Restart	
Not Assigned (default)						
			Talk Key	Tap Key		
GPIO Outputs						
Relay 1		Not Assigned (default)				
Relay 2		Talk Key	Tap Key			
UPG1 – UPG9						
Mirror						
<a list of available target keypanels>						

OMNEO Setup	
OKP	
OEI-2 (if attached)	
Device Name	<displays device name and allows editing>
DHCP	
	Disabled (default) Enabled
IP Parameters	
	IP Address <displays IP Address and allows editing> Netmask <displays Netmask and allows editing> Gateway <displays Gateway and allows editing> DNS Server 1 <displays DNS Server and allows editing> Domain <displays Domain Name and allows editing>
Page Change	
Auto (default) Always Allow No Talk Keys	
Reset Cfg	
Cancel Do Reset	
	Configuration Reset
Scrn Saver	
Activate	
Delay	
Display Dim	Delay Time: 1 hour (default) (30 min, 1 – 12 hours, and Disabled)
Activation	Delay Time: 1 hour (default) (30 min, 1 – 12 hours, and Disabled)
Display Dim	
	Brightness: 25% (default) (0% – 100%)
Mode	
Bitmap	Bounce Scroll (default)
Display Off	
Text (default)	Bounce Scroll (default)
Set Address	
Poll ID <1–8>	
Cancel	
Save and Restart	
Snoop Tally	
Chime:	
	none (default), System #1 - System #12 (User #1-4 available only with the Audio Package)
Duration:	
	One-shot (default) (1 sec, 2 sec, 3 sec, 4 sec, 5 sec, 10 sec, 15 sec, 20 sec, 30 sec, 60 sec, 90 sec, 2 min, 3 min, 4 min, 5 min)
Test Panel	

Unicode Support

AZedit and Unicode Support

Minimum firmware revision requirements for Unicode support are:

- MCII-e v2.4.0 or later
- AIO-8 v10.5.0 or later
- AIO-16 v1.3.0 or later
- Cronus v1.8.0 or later
- Zeus III v1.3.0
- KP 32 CLD v1.3.0 or later
- KP 12 CLD v1.1.0
- RP-1000 v2.0.0
- KP12/4U v1A.0.26 (Cyrillic character set only)
- DKP-4016 v1.1.1

To **configure the keypad for Unicode operation**, do the following:

1. On the keypad, select **Service|Alphas|8 Chars (Unicode)|Save and Restart**.

NOTE: If using the keypad with Japanese firmware, you must also configure the correct Intercom Mode. See “Service Menu, Intercom Mode” on page 228.

2. From the Options menu in AZedit, select **Preferences**.
The Application Preferences window appears.
3. Select the **Advanced** tab.
The Advanced page appears.
4. Select the **Allow intercom resizing in ONLINE mode** check box.

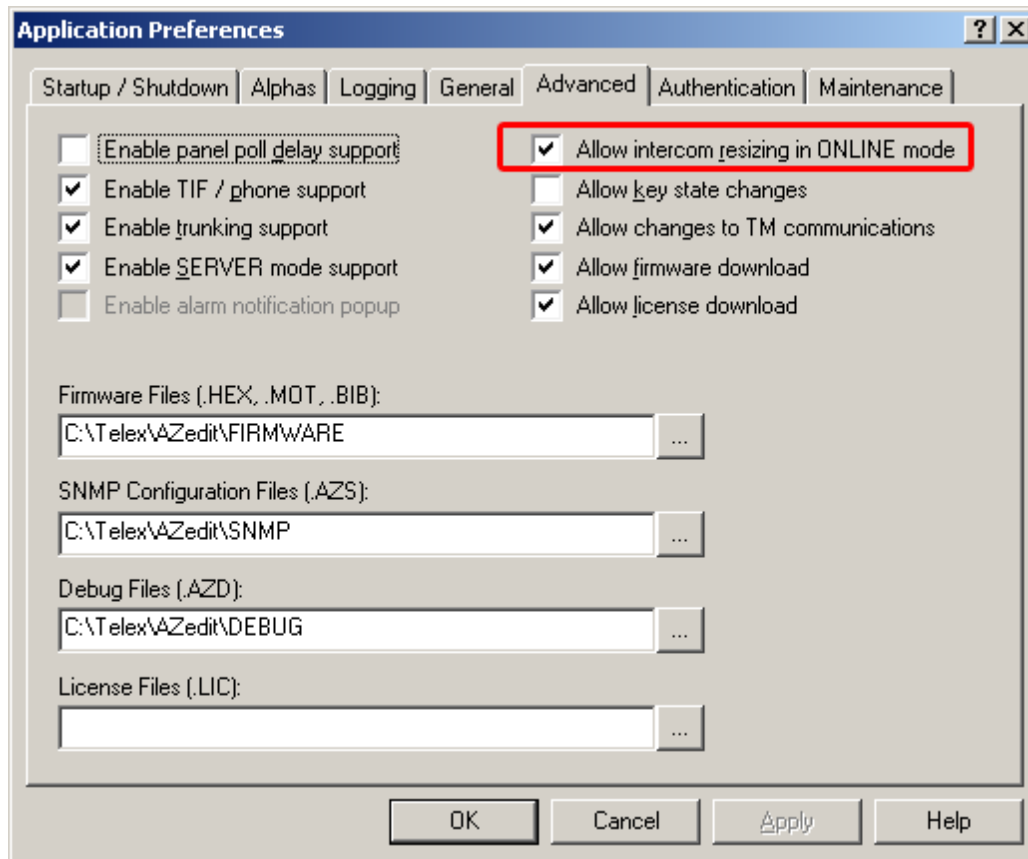

5. Click **Apply**.
6. Click **OK**.
The Application Preferences window closes.

IMPORTANT: You are about to erase the entire intercom setup! Be sure to save your file.

7. From the Options menu, select **Intercom Configuration**.
The Intercom Configuration window appears.
8. Click the **Options** tab.
The Options page appears.

9. Select the **Enable Unicode Alphas** check box.

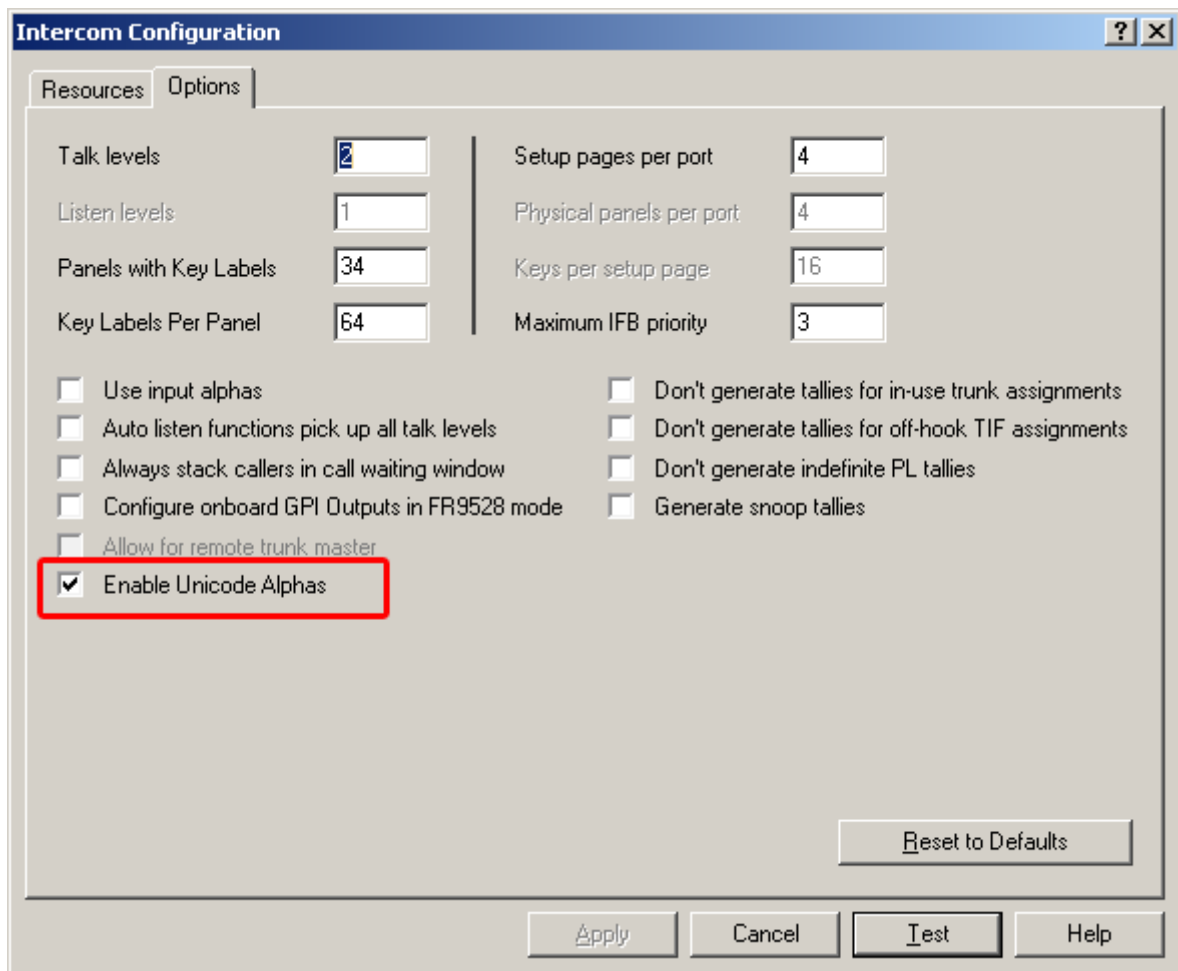

10. Click **Apply**.
The Intercom Configuration window closes.
11. From the Options menu, select **Preferences**.
The Application Preferences window appears.
12. Click the **Alphas** tab.
The Alphas window appears.

- From the Preferred alpha size drop down menu, select **8-UNICODE characters**.

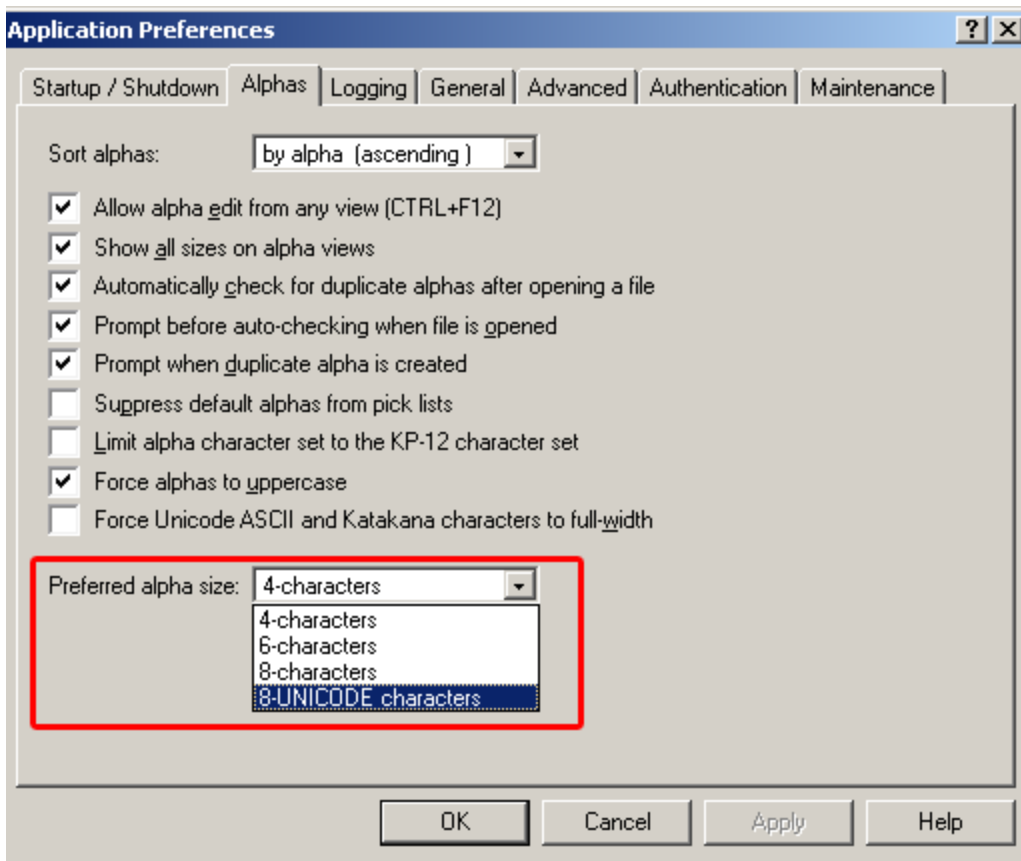

- Click **Apply**.

- Click **OK**.

The Application Preference window closes.

To **restore the system configuration**, do the following:

- From the Online menu, select **Send File**.
- Navigate to the **system configuration file (.adm)** you want to restore.
- Click **OK**.

Wall Mounting Option

Wall Mount Instructions

To wall mount the DKP-4016W, do the following:

1. Using the screw-hole template and a pencil, mark the **three(3) hole locations** on the wall.

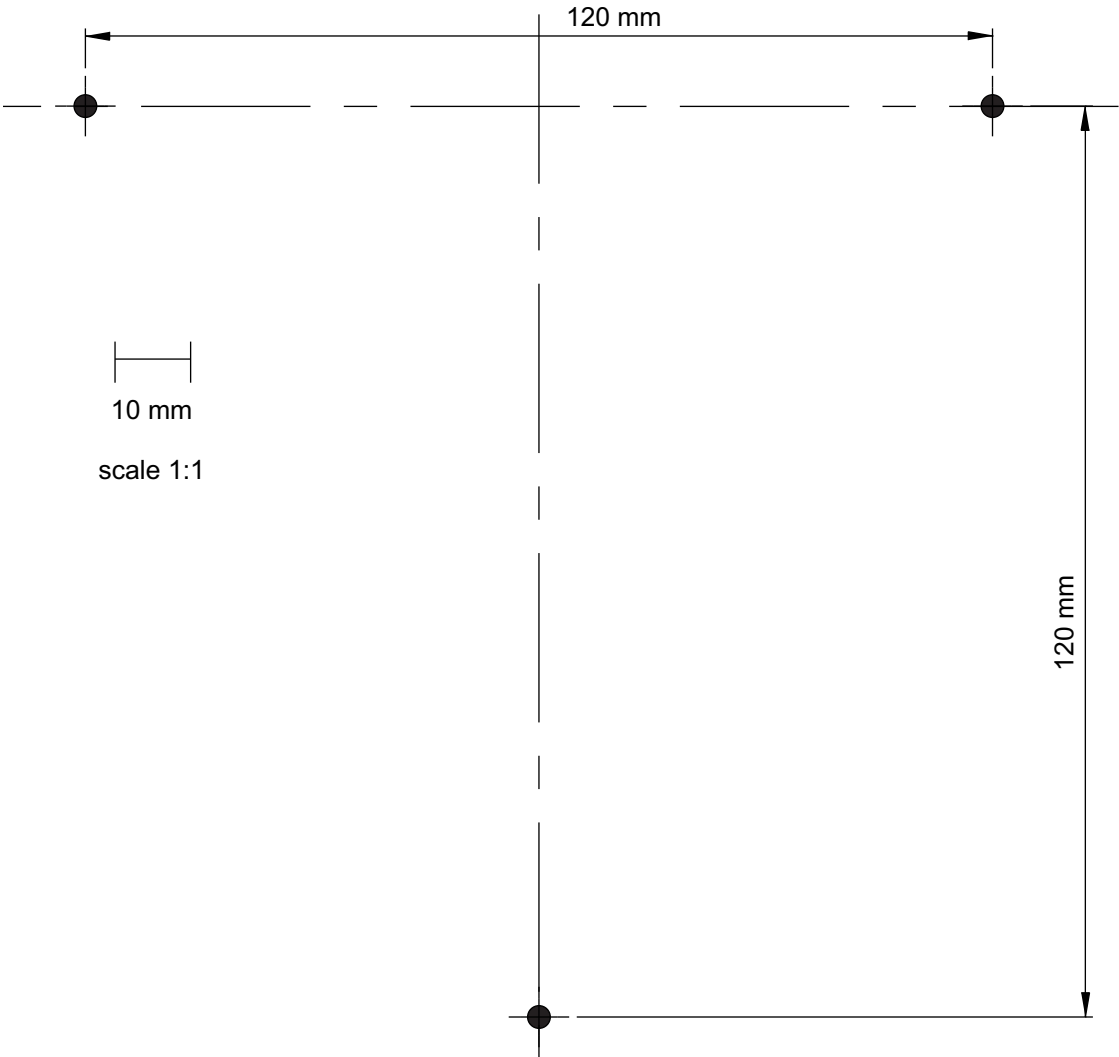

NOTE:

- It may be necessary to predrill the holes or use screw anchors, depending on the type of material the wall is constructed.
 - The DKP-4016W is supplied with three (3) wood screws. If you need to use different screws due to different wall material, be sure to adhere to the following guidelines:
 - Screw diameter: M5
 - Head diameter: no more than 10mm across
 - Head height: no more than 3.5mm tall
2. Using a screw driver, drive the **screws** into the predefined holes.

IMPORTANT: It is necessary for all screws to protrude from the wall at approximately the same height. The height should be 4-6mm from the underside of the screw head to the wall.

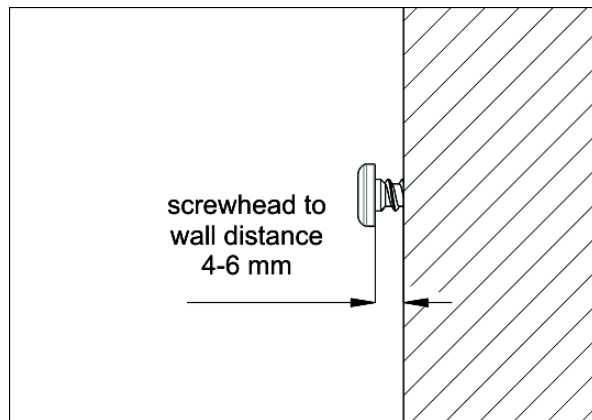

- If the screw is inserted too far, the unit cannot latch in place.
 - If the screw is not inserted far enough, the unit is not locked in place properly and can potentially fall off the wall.
-

3. Align the **bottom of the unit** over the screws, allowing the screw heads to slide into the largest part of the key hole opening.

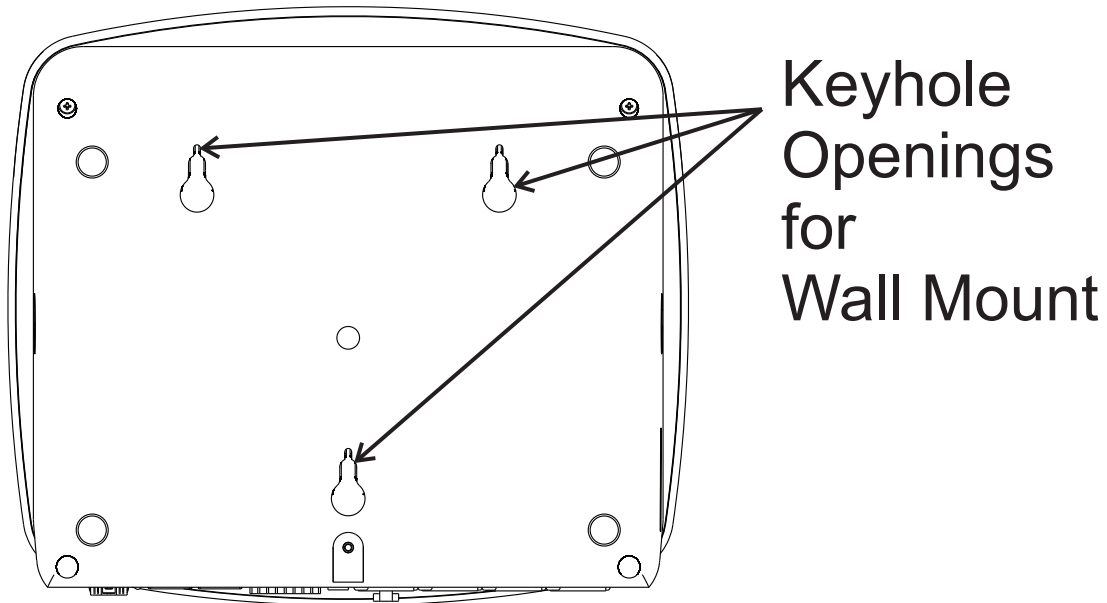

Bottom-side of DKP-4016W unit

IMPORTANT: Make sure all the screws are secure in the keyholes on the bottom of the unit.

4. Gently slide the **unit downward**, ensuring it locks into place.

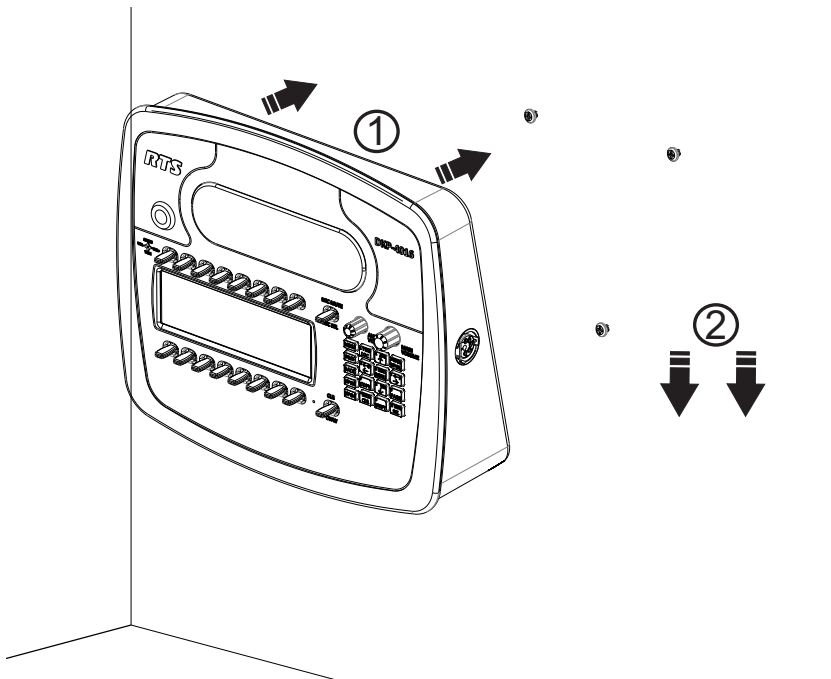

Audio and Control Packages

Audio and Control Add-On Packages

The Audio and Control Add-On Packages for the DKP-4016/4016W greatly expand your keypanel and intercom system experience and capabilities. The Audio package delivers voice messaging for when a user has stepped away from a panel, additional OMNEO channels, additional equalization bands, and adjustable compression and noise gating. The Control package offers real-time control of keypanels from AZedit as well as from another keypanel. It also offers KP Configuration from AZedit, allowing you to upload a keypanel configuration from a keypanel, make changes to the configuration and then download it to one or multiple licensed keypanels across your system. In addition, it includes two ways of customizing the keypanel with downloadable chimes and downloadable screen savers.

Below is a chart detailing what is included with each package.

Audio Package	Control Package
<ul style="list-style-type: none"> • Additional AUX Channels 3 – 8 via OMNEO • Voice Messaging (See “Voice Messaging (Audio Package Only)” on page 59.) • Adjustable Compression (See “Compression” on page 180.) • Adjustable Noise Gating (See “Noise Gate – Audio Package Only” on page 190.) • 5-band Equalization (See “Adjustable 5-Band Equalization – Audio Package Only” on page 183.) 	<ul style="list-style-type: none"> • Downloadable Screen Saver (See “Download Screen Savers (Control Package Only)” on page 171.) • Real-time Control (See “Real-Time Control in AZedit (Control Package Only)” on page 89.) • Keypanel Mirroring Mode (See “Keypanel Mirroring (Control Package Only)” on page 86.) • Keypanel Configuration (See “Keypanel Configuration (Control Package Only)” on page 99.) • Downloadable Chimes (See “Download User Chimes (Control Package Only)” on page 169.)

Steps to getting the packages

Step 1 Upgrade AZedit to version 5.2.0.

Step 2 Download the firmware version 1.2.0 to the keypanel. For download information, see “Download Firmware to the DKP-4016/4016W From AZedit” on page 151.

Step 3 Download the license files to your keypanel. (downloaded like firmware)

Step 4 Download the VM chimes and icons (downloaded like firmware)

NOTE: For information on downloading firmware, see “Download Firmware to the DKP-4016/4016W From AZedit” on page 151. Take note, the VM chimes and VM icons are .mot files and should be treated as firmware downloads, not Chimes or Icons. Panels shipped from the factory with v1.2.0 or higher, include VM chimes and VM icons pre-installed.

Download License Files

License files activate the packages you have purchased. Similar to firmware files, license files are downloaded to the to keypanel via AZedit; unlocking the intended features

To **download/activate license files**, do the following:

1. Open **AZedit**.
2. From the Status menu, select **Software Versions|Keypanels**.
The Keypanel Version Information window appears.
3. Select the **port number** where the keypanel with the license is located.
4. Highlight the **Port** (keypanel) to be updated.
You may select more than one (1) at a time by holding CTRL key down while you select. But, you must make sure every MAC ID matches before downloading.

IMPORTANT: To find the MAC Address of the keypanel, do one of the following:

- Find it in IPedit
- Find it in the Display menu at “Display Menu, MAC Address” on page 206
- Find it in the Info menu at “INFO button” on page 39

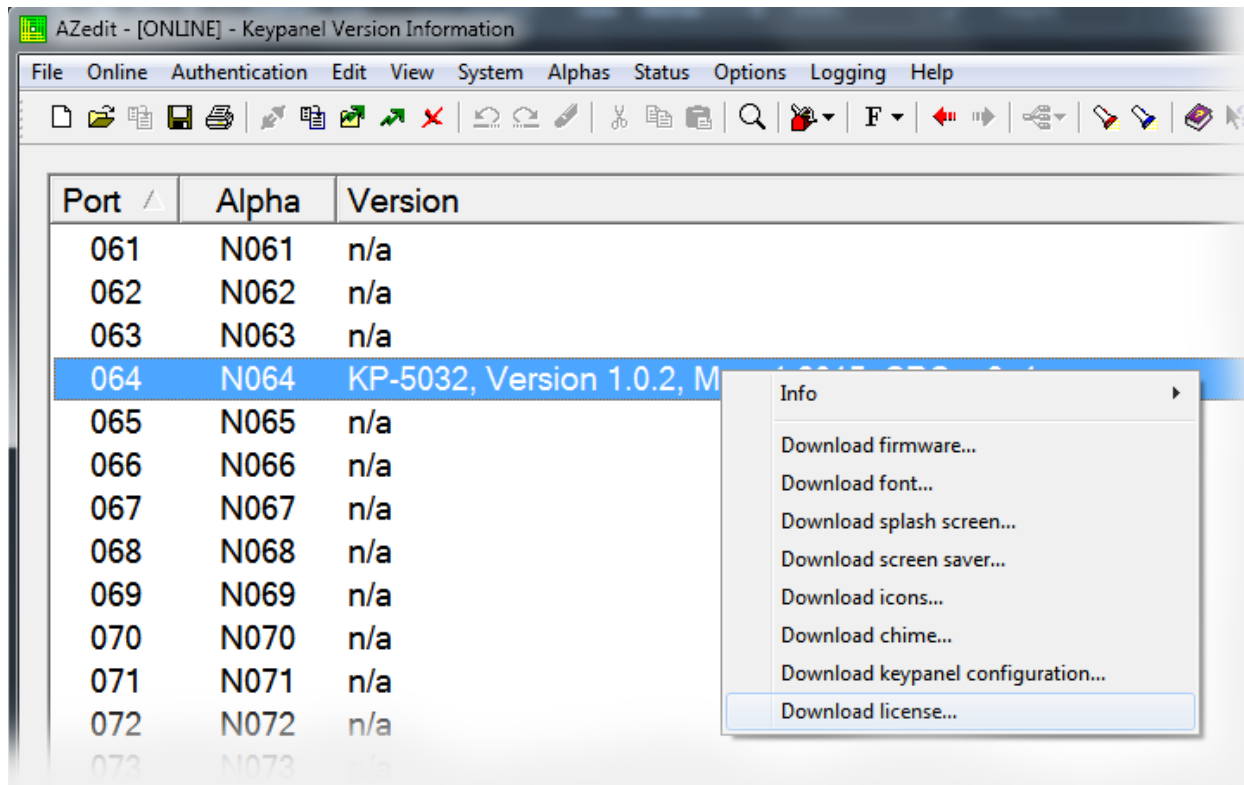

5. Right-click the **highlighted selections**.
A popup menu appears.
6. Select **Download license....**
The License Download window appears.
7. Navigate to the **license file**.

- Click **Open**.
The Download License File window appears.

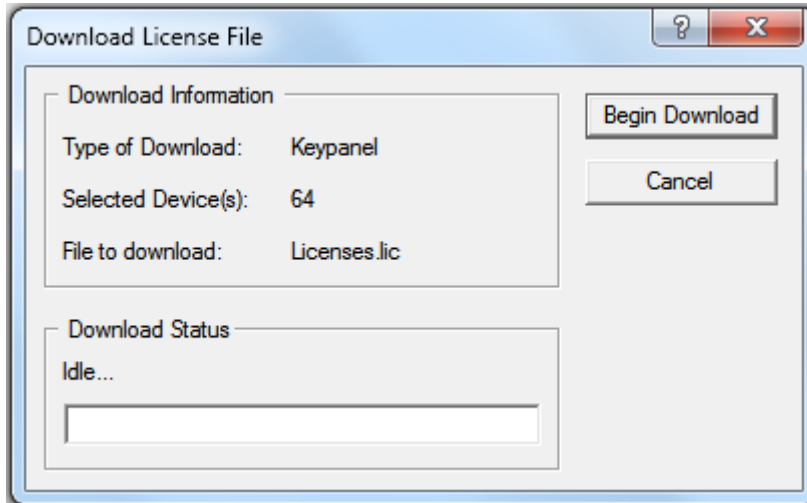

- Click **Begin Download**.
The license file is downloaded and unlocks the licensed features purchased.

Once you have installed the package(s) you purchased, the following icon appears at power up for five seconds and then disappears:



Only the Audio Package is installed.



Only the Control Package is installed.



Both the Audio and Control Packages are installed.

Bosch Security Systems, Inc.

12000 Portland Avenue South

Burnsville, MN 55337 U.S.A.

www.boschcommunications.com